

# HUMAN FACTORS TRAINING MANUAL

Doc 9683-AN/950

FIRST EDITION – 1998



# AMENDMENTS

The issue of amendments is announced regularly in the *ICAO Journal* and in the monthly *Supplement to the Catalogue of ICAO Publications and Audio-visual Training Aids*, which holders of this publication should consult. The space below is provided to keep a record of such amendments.

## RECORD OF AMENDMENTS AND CORRIGENDA

AMENDMENTS			
No.	Date applicable	Date entered	Entered by
1	30/09/03	24/8/06	TN TT
2	31/5/05	24/8/06	TN TT

CORRIGENDA			
No.	Date applicable	Date entered	Entered by

## FOREWORD

Safety of the civil aviation system is the major objective of the International Civil Aviation Organization. Considerable progress has been made, but additional improvements are needed and can be achieved. It has long been known that some three out of four accidents result from less than optimum human performance, indicating that any advance in this field can be expected to have a significant impact on the improvement of flight safety.

This was recognized by the ICAO Assembly, which in 1986 adopted Resolution A26-9 on Flight Safety and Human Factors. As a follow-up to the Assembly Resolution, the Air Navigation Commission formulated the following objective for the task:

“To improve safety in aviation by making States more aware and responsive to the importance of human factors in civil aviation operations through the provision of practical human factors material and measures developed on the basis of experience in States, and by developing and recommending appropriate amendments to existing materials in Annexes and other documents with regard to the role of human factors in the present and future operational environments. Special emphasis will be directed to the human factors issues that may influence the design, transition and in-service use of the [future] ICAO CNS/ATM systems.”

One of the methods chosen to implement Assembly Resolution A26-9 was the publication of a series of digests which addressed various aspects of Human Factors and its impact on flight safety. These digests were intended

primarily for use by States to increase the awareness of their personnel of the influence of human performance on safety.

The digests were aimed at the managers of both civil aviation administrations and the airline industry, including airline operational and training managers. The target audience also included regulatory bodies, safety and investigation agencies and training establishments, as well as senior and middle non-operational airline management.

This manual is essentially an edited compilation of the series of ICAO Human Factors digests. Its target audience includes senior training, operational and safety personnel in industry and regulatory bodies. It comprises two parts:

*Part 1 — General* introduces the concept of aviation Human Factors, presents a systemic and contemporary view of aviation safety, outlines the basic principles of workstation design and reviews the fundamental Human Factors issues in various aviation domains, including air traffic control and maintenance.

*Part 2 — Training Programmes for Operational Personnel* outlines Human Factors training issues and proposes the contents of sample training curricula for pilots, air traffic controllers and accident investigators.

This manual is intended to be kept up to date. It will be amended periodically as new research becomes available to reflect increased knowledge on Human Factors training for operational personnel.

# TABLE OF CONTENTS

	<i>Page</i>		<i>Page</i>
<b>PART 1. GENERAL</b>		<b>Chapter 4. Ergonomics</b> .....	<b>1-4-1</b>
<b>Chapter 1. Fundamental Human Factors</b>		4.1 Introduction .....	1-4-1
<b>Concepts</b> .....	<b>1-1-1</b>	4.2 Basic facts about ergonomics .....	1-4-1
1.1 Introduction .....	1-1-1	4.3 Human capabilities .....	1-4-4
1.2 The meaning of Human Factors .....	1-1-1	4.4 Human information processing .....	1-4-8
1.3 The industry need for Human Factors .....	1-1-5	4.5 Human dimensions .....	1-4-10
1.4 Human Factors applications in aviation operations .....	1-1-8	4.6 Displays, controls and flight deck design .....	1-4-12
List of references .....	1-1-16	4.7 The environment .....	1-4-25
		List of references .....	1-4-29
<b>Chapter 2. Human Factors, Management and Organization</b> .....	<b>1-2-1</b>	<b>Chapter 5. Human Factors issues in air traffic control</b> .....	<b>1-5-1</b>
2.1 Introduction .....	1-2-1	5.1 Introduction .....	1-5-1
2.2 From individuals to organizations .....	1-2-2	5.2 Human Factors within systems .....	1-5-1
2.3 Safe and unsafe organizations .....	1-2-6	5.3 Automation in air traffic control .....	1-5-5
2.4 Allocation of resources .....	1-2-11	5.4 The selection and training of air traffic controllers .....	1-5-12
2.5 Management's contribution to safety .....	1-2-15	5.5 The human element — specific attributes .....	1-5-16
		List of references .....	1-5-22
<b>Chapter 3. Human Factors issues in the development and implementation of Communications Navigation and Surveillance/Air Traffic Management (CNS/ATM) systems</b> .....	<b>1-3-1</b>	Appendix to Chapter 5 .....	1-5-26
3.1 Introduction .....	1-3-1	<b>Chapter 6. Human Factors in aircraft maintenance and inspection</b> .....	<b>1-6-1</b>
3.2 The ICAO CNS/ATM concept .....	1-3-3	6.1 Introduction .....	1-6-1
3.3 Automation in advanced aviation systems .....	1-3-6	6.2 Human Factors — aircraft maintenance and inspection .....	1-6-2
3.4 Human-centred technology .....	1-3-12	6.3 Human error in aircraft maintenance and inspection: an organizational perspective .....	1-6-3
3.5 Principles of human-centred automation .....	1-3-15	6.4 Human Factors issues affecting aircraft maintenance .....	1-6-9
3.6 Qualities of human-centred automation .....	1-3-19		
List of references .....	1-3-24		

	<i>Page</i>
6.5 Teams and organizational issues in aircraft maintenance .....	1-6-16
6.6 Automation and advanced technology systems .....	1-6-18
6.7 Error prevention considerations and strategies.....	1-6-20
List of references .....	1-6-24

**PART 2. TRAINING PROGRAMMES FOR OPERATIONAL PERSONNEL**

<b>Chapter 1. Basic human performance training programmes for operational personnel .....</b>		<b>2-1-1</b>
1.1 Introduction .....		2-1-1
1.2 Human Factors training for operational personnel: an introduction and overview .....	2-1-2	
1.3 The prior situation.....	2-1-2	
1.4 Human Factors highlights.....	2-1-3	
1.5 The SHELL Model .....	2-1-5	
1.6 The implications of the provisions from Annexes 1 and 6, Part I .....	2-1-5	
1.7 Human performance training curriculum: an ICAO proposal.....	2-1-7	
1.8 Human performance training curriculum for pilots.....	2-1-7	
1.9 The skill requirement .....	2-1-10	
1.10 Human performance training curriculum for air traffic controllers..	2-1-11	
1.11 Human performance training for maintenance technicians .....	2-1-14	
1.12 Considerations in training implementation and curriculum development .....	2-1-14	
1.13 Training philosophy and objectives ..	2-1-15	
1.14 Skill development, operational personnel assessment and training course evaluation.....	2-1-17	
1.15 Human performance training curriculum for aircraft maintenance engineers ...	2-1-17	
Appendix 1 to Chapter 1 .....	2-1-23	
Appendix 2 to Chapter 1 .....	2-1-25	
Appendix 3 to Chapter 1 .....	2-1-29	

<b>Chapter 2. Crew resource management (CRM) training .....</b>		<b>2-2-1</b>
2.1 Introduction .....		2-2-1
2.2 Crew resource management (CRM) training .....		2-2-1
2.3 Threat and error management (TEM) training .....		2-2-8
2.4 Guidance for integrating TEM into CRM .....		2-2-12
2.5 Line-oriented flight training (LOFT) ..		2-2-20
List of recommended reading .....		2-2-27

<b>Chapter 3. Training issues in automation and advanced technology flight decks .....</b>		<b>2-3-1</b>
3.1 Introduction .....		2-3-1
3.2 An introduction to automation .....		2-3-1
3.3 Issues and concerns in automation...		2-3-6
3.4 Training for automation .....		2-3-14
3.5 Management techniques and coping strategies .....		2-3-18
List of recommended reading .....		2-3-21
Appendix 1 to Chapter 3 .....		2-3-24
Appendix 2 to Chapter 3 .....		2-3-29
Appendix 3 to Chapter 3 .....		2-3-31

<b>Chapter 4. Human Factors training for safety investigators .....</b>		<b>2-4-1</b>
4.1 Introduction .....		2-4-1
4.2 Need for and purpose of Human Factors investigation .....		2-4-2
4.3 Conduct of the investigation.....		2-4-9
4.4 Reporting and preventive action.....		2-4-21
Appendix 1 to Chapter 4 .....		2-4-28
Appendix 2 to Chapter 4 .....		2-4-36
Appendix 3 to Chapter 4 .....		2-4-40
Appendix 4 to Chapter 4 .....		2-4-42
Appendix 5 to Chapter 4 .....		2-4-44

**Notes**

**PART 1**  
**GENERAL**

# CHAPTER 1

## FUNDAMENTAL HUMAN FACTORS CONCEPTS

### 1.1 INTRODUCTION

**1.1.1** Human performance is cited as a causal factor in the majority of aircraft accidents. If the accident rate is to be decreased, Human Factors issues in aviation must be better understood and Human Factors knowledge more broadly and proactively applied. By proaction it is meant that Human Factors knowledge should be applied and integrated during the systems design and certification stages, as well as during the operational personnel certification process, before the systems and the people become operational. The expansion of Human Factors awareness presents the international aviation community with the single most significant opportunity to make aviation both safer and more efficient. The purpose of this chapter is to present an overview of the various components which constitute Human Factors and to clarify its meaning.

**1.1.2** Ever since humans began to make tools, thousands of years ago, the application of elementary ergonomics has improved work efficiency. But it is only during the last hundred years that the modern evolution of ergonomics towards Human Factors has begun.

**1.1.3** The need during the First World War to optimize factory production and to assign thousands of recruits more effectively to military duties, and the fact that during the Second World War sophisticated equipment was surpassing human capability to operate it with maximum effectiveness provided further stimulus to Human Factors progress. Selection and training of staff, too, began to be approached more scientifically. However, it might be argued that the renewed interest in Human Factors contribution to aviation safety was a reactive response to technological limitations prevailing at the time. Therefore, human capabilities were extended to their maximum through the application of Human Factors knowledge, sometimes at the cost of overlooking human limitations.

**1.1.4** The institutionalization of Human Factors occurred with the founding of several organizations such as the Ergonomics Research Society in 1949, the Human Factors Society (now Human Factors and Ergonomics Society) in 1957 and the International Ergonomics Association (IEA) in 1959.

**1.1.5** The recognition that basic Human Factors education was needed throughout the industry led to various approaches to formal training in different countries. This recognition, tragically emphasized by the investigation of a number of accidents resulting almost entirely from deficiencies in the application of Human Factors, led ICAO to implement Human Factors training requirements into the training and licensing requirements included in Annex 1 (1989) and Annex 6 (1995), as well as into the process of accident investigations included in Annex 13 (1994).

**1.1.6** The 1976 agreement between the United States Federal Aviation Administration (FAA) and the National Aeronautics and Space Administration (NASA) to establish a voluntary, non-punitive, confidential Aviation Safety Reporting System (ASRS) constituted official recognition that adequate information for analysis of human behaviour and errors in human performance is best obtained by eliminating the threat of punitive action against the person making the report. Similar schemes were later set up in the United Kingdom (CHIRP), Canada (CASRP) and Australia (CAIR).

**1.1.7** This chapter outlines:

- 1) the meaning and definition of Human Factors, a conceptual model of it, and clarification of common misconceptions;
- 2) the industry need for Human Factors; and
- 3) a brief overview of the application of Human Factors in flight operations.

### 1.2 THE MEANING OF HUMAN FACTORS

**1.2.1** Human Factors as a term has to be clearly defined because when these words are used in the vernacular they are often applied to any factor related to humans. The human element is the most flexible, adaptable and valuable part of the aviation system, but it is also

the most vulnerable to influences which can adversely affect its performance. Throughout the years, some three out of four accidents have resulted from less than optimum human performance. This has commonly been classified as human error.

1.2.2 The term "human error" is of no help in accident prevention because although it may indicate WHERE in the system a breakdown occurs, it provides no guidance as to WHY it occurs. An error attributed to humans in the system may have been design-induced or stimulated by inadequate training, badly designed procedures or the poor concept or layout of checklists or manuals. Further, the term "human error" allows concealment of the underlying factors which must be brought to the fore if accidents are to be prevented. In fact, contemporary safety-thinking argues that human error should be the starting point rather than the stop-rule in accident investigation and prevention.

1.2.3 An understanding of the predictable human capabilities and limitations and the application of this understanding are the primary concerns of Human Factors. Human Factors has been progressively developed, refined and institutionalized since the end of the last century, and is now backed by a vast store of knowledge which can be used by those concerned with enhancing the safety of the complex system which is today's civil aviation. Throughout this manual capital initial letters are used for the term "Human Factors". The terms "human aspects" and "human elements" in common usage are helpful alternatives to avoid ambiguity and aid comprehension.

### The disciplines of Human Factors

1.2.4 Many of the early concerns in aviation were related to the effects on people of noise, vibration, heat, cold and acceleration forces. Usually, the person nearest at hand with a knowledge of physiology was a physician; this may have generated one of the more persistent misconceptions about Human Factors, the belief that it is somehow a branch of medicine. Yet half a century ago work was expanding on the more cognitive aspects of aviation tasks and this trend has continued and is outside the scope of medicine. Optimizing the role of people in this complex working environment involves all aspects of human performance: decision-making and other cognitive processes; the design of displays and controls and flight deck and cabin layout; communication and computer software; maps and charts; and the field of documentation such as aircraft operating manuals, checklists, etc. Human Factors knowledge is also increasingly used in staff

selection, training and checking and in accident prevention and investigation.

1.2.5 Human Factors is multidisciplinary in nature. For example, information is drawn from psychology to understand how people process information and make decisions. From psychology and physiology comes an understanding of sensory processes as the means of detecting and transmitting information on the world about us. The measures and movements of the body — essential in optimizing the design and layout of controls, and other workplace characteristics of the flight deck and cabin — call upon anthropometry and biomechanics. Biology and its increasingly important sub-discipline, chronobiology, are needed to understand the nature of the body's rhythms and sleep, and their effects in night flying and time-zone changes. No proper analysis or presentation of data from surveys or studies is possible without some basic understanding of statistics. While utilizing these academic sources of knowledge, Human Factors is essentially concerned with solving practical problems in the real world. Human Factors is practical in nature; it is problem-oriented rather than discipline-centred.

1.2.6 Human Factors is about people in their living and working situations; about their relationship with machines, with procedures and with the environment about them; and also about their relationships with other people. One definition of Human Factors, as proposed by Professor Edwards, declares that "Human Factors is concerned to optimize the relationship between people and their activities, by the systematic application of human sciences, integrated within the framework of systems engineering". Its objectives can be seen as effectiveness of the system, which includes safety and efficiency, and the well-being of the individual. Professor Edwards further elaborates that "activities" indicates an interest in communication between individuals and in the behaviour of individuals and groups. Lately, this has been expanded upon to include the interactions among individuals and groups and the organizations to which they belong, and to the interactions among the organizations that constitute the aviation system. The human sciences study the structure and nature of human beings, their capabilities and limitations, and their behaviours both singly and in groups. The notion of integration within systems engineering refers to the Human Factors practitioner's attempts to understand the goals and methods as well as the difficulties and constraints under which people working in interrelated areas of engineering must make decisions. Human Factors uses this information based on its relevance to practical problems.

1.2.7 The term "ergonomics" derives from the Greek words "ergon" (work) and "nomos" (natural law). It is



defined as “the study of the efficiency of persons in their working environment”. In some States, the term ergonomics is used strictly to refer to the study of human-machine system design issues. Chapter 3 introduces a discussion on ergonomics.

### A conceptual model of Human Factors

1.2.8 It is helpful to use a model to aid in the understanding of Human Factors, as this allows a gradual approach to comprehension. One practical diagram to illustrate this conceptual model uses blocks to represent the different components of Human Factors. The model can then be built up one block at a time, with a pictorial impression being given of the need for matching the components. The SHEL concept (the name being derived from the initial letters of its components, Software, Hardware, Environment, Liveware) was first developed by Edwards in 1972, with a modified diagram to illustrate the model developed by Hawkins in 1975. The following interpretations are suggested: liveware (human), hardware

(machine), software (procedures, symbology, etc.), and environment (the situation in which the L-H-S system must function). This building block diagram does not cover the interfaces which are outside Human Factors (hardware-hardware; hardware-environment; software-hardware) and is only intended as a basic aid to understanding Human Factors.

1.2.9 Liveware. In the centre of the model is a person, the most critical as well as the most flexible component in the system. Yet people are subject to considerable variations in performance and suffer many limitations, most of which are now predictable in general terms. The edges of this block are not simple and straight, and so the other components of the system must be carefully matched to them if stress in the system and eventual breakdown are to be avoided.

1.2.10 In order to achieve this matching, an understanding of the characteristics of this central component is essential. Some of the more important characteristics are the following:

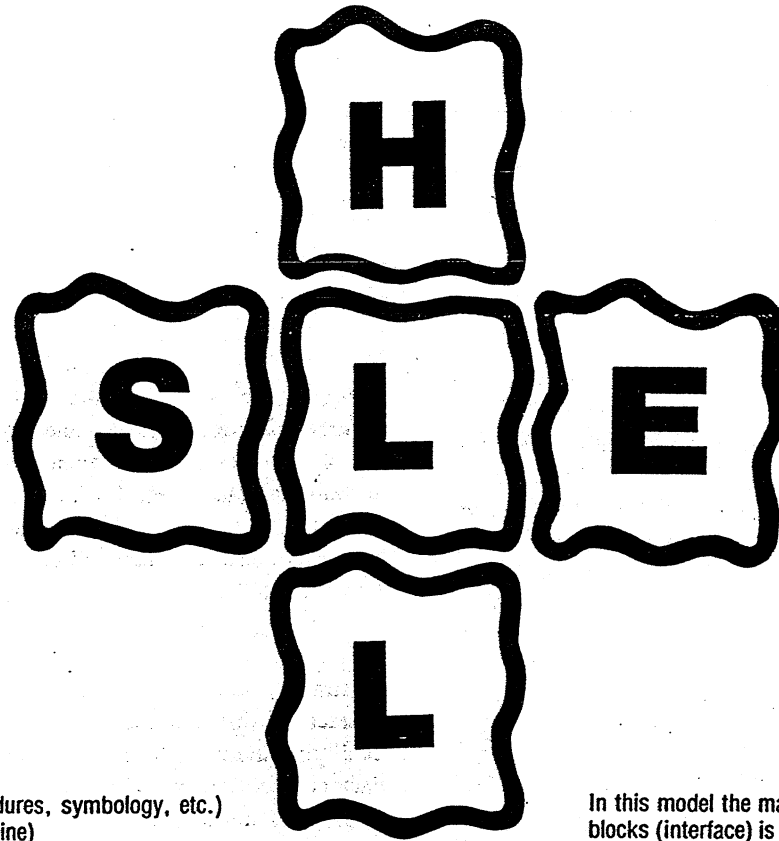

S = Software (procedures, symbology, etc.)  
 H = Hardware (machine)  
 E = Environment  
 L = Liveware (human)

In this model the match or mismatch of the blocks (interface) is just as important as the characteristics of the blocks themselves. A mismatch can be a source of human error.

The-SHEL model as modified by Hawkins

- a) **Physical size and shape.** In the design of any workplace and most equipment, a vital role is played by body measurements and movements, which will vary according to age and ethnic and gender groups. Decisions must be made at an early stage in the design process, and the data for these decisions are available from anthropometry and biomechanics.
- b) **Physical needs.** People's requirements for food, water and oxygen are available from physiology and biology.
- c) **Input characteristics.** Humans have been provided with a sensory system for collecting information from the world around them, enabling them to respond to external events and to carry out the required task. But all senses are subject to degradation for one reason or another, and the sources of knowledge here are physiology, psychology and biology.
- d) **Information processing.** These human capabilities have severe limitations. Poor instrument and warning system design has frequently resulted from a failure to take into account the capabilities and limitations of the human information processing system. Short- and long-term memory are involved, as well as motivation and stress. Psychology is the source of background knowledge here.
- e) **Output characteristics.** Once information is sensed and processed, messages are sent to the muscles to initiate the desired response, whether it be a physical control movement or the initiation of some form of communication. Acceptable control forces and direction of movement have to be known, and biomechanics, physiology and psychology provide such knowledge.
- f) **Environmental tolerances.** Temperature, pressure, humidity, noise, time of day, light and darkness can all be reflected in performance and also in well-being. Heights, enclosed spaces and a boring or stressful working environment can also be expected to influence performance. Information is provided here by physiology, biology and psychology.

The Liveware is the hub of the SHEL model of Human Factors. The remaining components must be adapted and matched to this central component.

**1.2.11 Liveware-Hardware.** This interface is the one most commonly considered when speaking of human-machine systems: design of seats to fit the sitting characteristics of the human body, of displays to match the sensory and information processing characteristics of the user, of controls with proper movement, coding and location. The user may never be aware of an L-H deficiency, even where it finally leads to disaster, because the natural human characteristic of adapting to L-H mismatches will mask such a deficiency, but will not remove its existence. This constitutes a potential hazard to which designers should be alert. With the introduction of computers and advanced automated systems, this interface has repositioned itself at the forefront of Human Factors endeavours.

**1.2.12 Liveware-Software.** This encompasses humans and the non-physical aspects of the system such as procedures, manual and checklist layout, symbology and computer programmes. Liveware-software problems are conspicuous in accident reports, but they are often difficult to observe and are consequently more difficult to resolve (for example, misinterpretation of checklists or symbology, non-compliance with procedures, etc.).

**1.2.13 Liveware-Environment.** The human-environment interface was one of the earliest recognized in flying. Initially, the measures taken all aimed at adapting the human to the environment (helmets, flying suits, oxygen masks, anti-G suits). Later, the trend was to reverse this process by adapting the environment to match human requirements (pressurization and air-conditioning systems, soundproofing). Today, new challenges have arisen, notably ozone concentrations and radiation hazards at high flight levels and the problems associated with disturbed biological rhythms and related sleep disturbance and deprivation as a consequence of the increased speed of transmeridian travel. Since illusions and disorientation are at the root of many aviation accidents the L-E interface must consider perceptual errors induced by environmental conditions, for example, illusions during approach and landing phases. The aviation system also operates within the context of broad political and economical constraints, and those aspects of the environment will interact in this interface. Although the possibility of modifying these influences is sometimes beyond Human Factors practitioners, their incidence is central and should be properly considered and addressed by those in management with the possibility to do so. This topic is fully developed in Chapter 2.

**1.2.14 Liveware-Liveware.** This is the interface between people. Training and proficiency testing have traditionally been done on an individual basis. If each

individual team member was proficient, then it was assumed that the team consisting of these individuals would also be proficient and effective. This is not always the case, however, and for many years attention has increasingly turned to the breakdown of teamwork. Flight crews, air traffic controllers, maintenance technicians and other operational personnel function as groups and group influences play a role in determining behaviour and performance. In this interface, we are concerned with leadership, crew co-operation, teamwork and personality interactions. Staff/management relationships are also within the scope of this interface, as corporate culture, corporate climate and company operating pressures can significantly affect human performance. Part 2 of this manual describes current industry approaches to Human Factors training programmes for operational personnel.

### 1.3 THE INDUSTRY NEED FOR HUMAN FACTORS

1.3.1 Admiral Donald Engen, the former Administrator of the United States Federal Aviation Administration, has been quoted as saying (1986): "We spent over fifty years on the hardware, which is now pretty reliable. Now it's time to work with people." This declaration somehow sets the foundation upon which the industry need for Human Factors can be assessed. Curiously enough, we retain a lawyer for advice about a legal problem, or hire an architect to build a house, or consult a physician when trying to establish the diagnosis of a medical problem, but when it comes to solving Human Factors problems, we have adopted an intuitive and in many cases perfunctory approach, even though many lives may depend on the outcome. A background of many years of industry experience or thousands of flying hours may have little or no significance when looking for the resolution of problems which only a thorough understanding of Human Factors can provide.

1.3.2 This is of special significance because, as already mentioned, it has long been known that some three out of four accidents result from performance errors made by apparently healthy and properly certificated individuals. The sources of some of these errors may be traced to poor equipment or procedure design or to inadequate training or operating instructions. But whatever the origin, the question of human performance capabilities and limitations and human behaviour is central to the technology of Human Factors. The cost, both in human and financial terms, of less than optimum human performance has become so great that a makeshift or intuitive approach to Human Factors is no longer appropriate. Safety being the ultimate objective of all those involved in aviation, its

logical follow-up is to ensure a proper level of Human Factors knowledge throughout the industry.

1.3.3 The industry need for Human Factors is based on its impact on two broad areas, which interrelate so closely that in many cases their influences overlap and factors affecting one may also affect the other. These areas are:

- Effectiveness of the system
  - safety
  - efficiency
- Well-being of operational personnel.

#### Effectiveness of the system

#### Safety

1.3.4 The best way to illustrate the effect of Human Factors issues on aviation safety is through the example of accidents. A few accidents in which aspects of Human Factors triggered the attention of the aviation community and paved the way to the proliferation of Human Factors endeavours in aviation are described here as examples.

- 1) In the same month — December 1972 — an L1011 crashed in the Florida Everglades (NTSB/AAR 73-14) and a B-737 crashed at Midway Airport in Chicago (NTSB/AAR 73-16). In the first case, duties were not properly allocated and the whole flight crew became preoccupied with a landing gear indicator light bulb. In the second case, the captain — as a leader — did not properly manage the resources which were available to him.
- 2) In 1974, a B-707 crashed during approach at Pago-Pago in Samoa, with a loss of 96 lives. A visual illusion related to the black-hole phenomenon was a cause factor (NTSB/AAR 74-15).
- 3) In 1974, a DC-10 crashed after take-off because a cargo door failed (it opened and blew out). The force applied by a cargo handler to close the cargo door, the door design and an incomplete application of a service bulletin were cited as factors (ICAO Circular 132-AN/93).
- 4) In 1974, a B-727 approaching Dulles Airport in Washington crashed into Mount Weather, with a loss of 92 lives. Lack of clarity and

inadequacies in air traffic control procedures and regulations led to the accident. The absence of timely action of the regulatory body to resolve a known problem in air traffic terminology was also listed as a factor (NTSB/AAR 75-16).

- 5) In 1977, two B-747s collided while on the runway at Tenerife, with a loss of 583 lives. A breakdown in normal communication procedures and misinterpretation of verbal messages were considered factors (ICAO Circular 153-AN/98).
- 6) In 1979, a DC-10 crashed into Mount Erebus in Antarctica. Information transfer and data entry errors played a role in the accident (Accident Report No. 79/139, New Zealand).
- 7) In 1982, a B-737 crashed after take-off in icing conditions in Washington. Erroneous engine thrust readings (higher than actual), and the co-pilot's lack of assertiveness in communicating his concern and comments about aircraft performance during the take-off run were among the factors cited (NTSB/AAR 82-08).
- 8) The report of a 1983 A300 accident in Kuala Lumpur suggests that variations in panel layout amongst the aircraft in the fleet had adversely affected crew performance. (The aircraft was on a dry lease.) (Accident Report No. 2/83, Malaysia).
- 9) In 1984, a DC-10 overran the runway at John F. Kennedy Airport in New York. Excessive reliance on automation was noted in the accident report (NTSB/AAR 84-15). Excessive reliance on automation was also listed as a factor in a loss of control incident in 1985, in which a B-747 lost 20 000 feet in less than two minutes and sustained structural damage (NTSB/AAR 86-03).
- 10) In 1987 an MD-80 crashed on take-off in Detroit. The pilots had not set the flaps, thus violating standard operating procedures. Also, the take-off configuration warning did not sound, for undetermined reasons (NTSB/AAR 88-05).

### *Efficiency*

1.3.5 The need for application of Human Factors is not limited to flight safety. Efficiency is also radically influenced by the application of, or the lack of, Human

Factors knowledge. For instance, neglect of Human Factors in flight operations can be expected to cause less than optimum performance of tasks. The following paragraphs are intended as an overview of particular applications of Human Factors knowledge which relate to efficiency.

1.3.6 Motivation can be explained as reflecting the difference between what a person can and actually will do; motivated individuals perform with greater effectiveness than unmotivated individuals. Human error and its consequences in aviation can be controlled by Human Factors technology, thus improving effectiveness.

1.3.7 The proper layout of displays and controls in the flight deck promotes and enhances effectiveness. Properly trained and supervised crew members are likely to perform more efficiently. From the perspective of efficiency, standard operating procedures (SOPs), which are developed to provide the most effective methods of operations, should be regarded as a means of measuring the performance of crew members.

1.3.8 Application of group interaction principles enhances the managerial position of the captain, whose leadership role is essential to the integration of a team and thus to more effective performance. The relationship between cabin attendants and passengers is also important. Cabin crew members should have an understanding of passenger behaviour and the emotions they can expect to encounter on board, as well as how to manage emotional situations.

### **Well-being of operational personnel**

1.3.9 Three of the many factors which may influence the well-being of operational personnel are fatigue, body rhythm disturbance, and sleep deprivation or disturbance. These are briefly explained below. Other factors affecting physiological or psychological well-being include temperature, noise, humidity, light, vibration, workstation design and seat comfort.

### *Fatigue*

1.3.10 Fatigue may be considered to be a condition reflecting inadequate rest, as well as a collection of symptoms associated with displaced or disturbed biological rhythms. Acute fatigue is induced by long duty periods or by a string of particularly demanding tasks performed in a short term. Chronic fatigue is induced by the cumulative effects of fatigue over the longer term. Mental fatigue may result from emotional stress, even with normal physical

rest. Like the disturbance of body rhythms, fatigue may lead to potentially unsafe situations and a deterioration in efficiency and well-being. Hypoxia and noise are contributing factors.

### *Body rhythm disturbance*

**1.3.11** The most commonly recognized of the body's rhythms is the circadian, or 24-hour rhythm, which is related to the earth's rotation time. This cycle is maintained by several agents: the most powerful are light and darkness, but meals and physical and social activities also have an influence on the body's systems. Safety, efficiency and well-being are affected by the disturbed pattern of biological rhythms typical of today's long-range flights. The impact of circadian dysrhythmia is relevant not only to long-distance transmeridian flying — short-haul operators (couriers and freight carriers, for instance) flying on irregular or night schedules can suffer from reduced performance produced by circadian dysrhythmia. Air traffic controllers and maintenance technicians with frequently changing shift schedules can suffer a similar deterioration in their performance.

**1.3.12** Jet lag is the common term for disturbance or desynchronization of body rhythms, and refers to the lack of well-being experienced after long-distance transmeridian air travel. Symptoms include sleep disturbance and disruption of eating and elimination habits, as well as lassitude, anxiety, irritability and depression. Objective evidence shows slowed reaction and decision-making times, loss of or inaccurate memory of recent events, errors in computation and a tendency to accept lower standards of operational performance.

### *Sleep*

**1.3.13** The most common physical symptoms associated with long-range flying result from disturbance of the normal sleep pattern, which may in some cases involve an over-all sleep deprivation. Adults usually take sleep in one long period each day; where this pattern has been established it becomes a natural rhythm of the brain, even when prolonged waking is imposed. Wide differences are found amongst individuals in their ability to sleep out of phase with their biological rhythms. Tolerance to sleep disturbance varies between crew members and is mainly related to body chemistry and, in some cases, to emotional stress factors.

**1.3.14** Insomnia defines a condition where a person has difficulty sleeping or when the quality of sleep is poor. When occurring under normal conditions and in phase

with the body rhythms, it is called primary insomnia. Circadian rhythm sleep disorder refers to difficulty in sleeping in particular situations where biological rhythms are disturbed, and is the one we are concerned about in long-range transmeridian flying.

**1.3.15** The use of drugs such as hypnotics, sedatives (including antihistamines with a sedative effect) and tranquilizers to induce sleep is usually inappropriate, as they have an adverse effect on performance when taken in therapeutic doses for up to 36 hours after administration. Alcohol is a depressant of the nervous system. It has a soporific effect, but it disturbs normal sleep patterns and entails poor quality of sleep. The effects persist after it has disappeared from the blood ("hangover"). Ingestion of hypnotics in combination with alcohol can have bizarre consequences. Caffeine in coffee, tea and various soft drinks increases alertness and normally reduces reaction times, but it is also likely to disturb sleep. Amphetamines, when used to maintain the level of performance during sleep deprivation, only postpone the effects of sleep loss.

**1.3.16** Sleep has a restorative function, and is essential for mental performance. Sleep deprivation and disturbance can reduce alertness and attention. When this phenomenon is recognized, alertness and attention can at least be partly restored by the application of extra effort. The relevance of this phenomenon to safety is obvious.

**1.3.17** The resolution of the problem of sleep disturbance or deprivation includes:

- scheduling crews with due consideration to circadian rhythms and fatigue resulting from sleep deprivation and disturbance;
- adapting the diet, understanding the importance of meal times, and adopting other measures in relation to light/darkness, rest/activity schedules and social interaction;
- recognizing the adverse long-term effect of drugs (including caffeine and alcohol);
- optimizing the sleeping environment; and
- learning relaxation techniques.

### **Health and performance**

**1.3.18** Certain pathological conditions — gastrointestinal disorders, heart attacks, etc. — have caused sudden pilot incapacitation and in rare cases have contributed to accidents. While total incapacitation is

usually quickly detected by other crew members, a reduction in capacity or partial incapacitation — produced by fatigue, stress, sleep, rhythm disturbances, medication, certain mild pathological conditions may go undetected, even by the person affected.

**1.3.19** Although no conclusive evidence is available, physical fitness may have a direct relationship to mental performance and health. Improved fitness reduces tension and anxiety and increases self-esteem. It has favourable effects on emotions, which affect motivation, and is believed to increase resistance to fatigue. Factors having a known influence on fitness include diet, exercise, stress levels and the use of tobacco, alcohol or drugs.

### Stress

**1.3.20** Stress can be found in many jobs, and the aviation environment is particularly rich in potential stressors. Of main interest is the effect of stress on performance. In the early days of aviation, stressors were created by the environment: noise, vibration, temperature, humidity, acceleration forces, etc., and were mainly physiological in nature. Today, some of these have been replaced by new sources of stress: irregular working and resting patterns and disturbed circadian rhythms associated with long-range, irregular or night-time flying.

**1.3.21** Stress is also associated with life events, such as family separation, and with situations such as periodic medical and proficiency checks. Even positive life events, such as a wedding or the birth of a child, can induce stress in normal life. Likewise, in situations where mental workload becomes very high, such as during take-off, landing or an in-flight emergency, mental stress may appear.

**1.3.22** Individuals differ in their responses to stress. For example, flight in a thunderstorm area may be challenging for one individual but stressful for another. The same stressor (the thunderstorm) produces different responses in different individuals, and any resulting damage should be attributed to the response rather than to the stressor itself.

## 1.4 HUMAN FACTORS APPLICATIONS IN AVIATION OPERATIONS

### Control of human error

**1.4.1** To contain and control human error, one must first understand its nature. There are basic concepts associated with the nature of human error: the origins of

errors can be fundamentally different; and the consequences of similar errors can also be significantly different. While some errors are due to carelessness, negligence or poor judgement, others may be induced by poorly designed equipment or may result from a normal reaction of a person to a particular situation. The latter kind of error is likely to be repeated and its occurrence can be anticipated.

### Errors at the model interfaces

**1.4.2** Each of the interfaces in the SHELL model has a potential of error where there is a mismatch between its components. For example:

- The interface between Liveware and Hardware (human and machine) is a frequent source of error: knobs and levers which are poorly located or lack of proper coding create mismatches at this interface.
- In the Liveware-Software interface, delays and errors may occur while seeking vital information from confusing, misleading or excessively cluttered documentation and charts.
- Errors associated with the Liveware-Environment interface are caused by environmental factors (noise, heat, lighting and vibration) and by the disturbance of biological rhythms in long-range flying resulting from irregular working/sleeping patterns.
- In the Liveware-Liveware interface, the focus is on the interaction between people because this process affects crew effectiveness. This interaction also includes leadership and command, and shortcomings at this interface reduce operational efficiency and cause misunderstandings and errors.

### Information processing

**1.4.3** Before a person can react to information, it must first be sensed; there is a potential for error here, because the sensory systems function only within narrow ranges. Once information is sensed, it makes its way to the brain, where it is processed, and a conclusion is drawn about the nature and meaning of the message received. This interpretative activity is called perception and is a breeding ground for errors. Expectation, experience, attitude, motivation and arousal all have a definite influence on perception and are possible sources of errors.

**1.4.4** After conclusions have been formed about the meaning of a message, decision-making begins. Many factors may lead to erroneous decisions: training or past experience; emotional or commercial considerations; fatigue, medication, motivation and physical or psychological disorders. Action (or inaction) follows decision. This is another stage with potential for error, because if equipment is designed in such a way that it can be operated wrongly, sooner or later it will be. Once action has been taken, a feedback mechanism starts to work. Deficiencies in this mechanism may also generate errors.

#### Controlling human error

**1.4.5** The control of human error requires two different approaches. First, it is necessary to minimize the occurrence of errors by: ensuring high levels of staff competence; designing controls so that they match human characteristics; providing proper checklists, procedures, manuals, maps, charts, SOPs, etc.; and reducing noise, vibration, temperature extremes and other stressful conditions. Training programmes aimed at increasing the co-operation and communication between crew members

will reduce the number of errors (the total elimination of human error is a difficult goal, since errors are a normal part of human behaviour). The second avenue to the control of human error is to reduce the consequences of the remaining errors by cross-monitoring and crew co-operation. Equipment design which makes errors reversible and equipment which can monitor or complement and support human performance also contribute to the limitation of errors or their consequences.

#### Training and evaluation

**1.4.6** The purpose of this section is to illustrate how Human Factors applies to the design of methods of operational training.

**1.4.7** Education and training are seen here as two different aspects of the teaching process. Education encompasses a broad-based set of knowledge, values, attitudes and skills required as a background upon which more specific job abilities can be acquired later. Training is a process aimed at developing specific skills, knowledge or attitudes for a job or a task. Proper and effective train-

### PLAIN TALK

Because of the high cost of aviation gasoline, a private pilot once wrote to his aviation administration and asked if he could mix kerosene in his aircraft fuel. He received the following reply:

"Utilization of kerosene involves major uncertainties/probabilities respecting shaft output and metal longevity where application pertains to aeronautical internal combustion power plants."

The pilot sent the following cable:

"Thanks for the information. Will start using kerosene next week."

He then received the following urgent letter:

"Regrettably decision involves uncertainties. Kerosene utilization consequences questionable, with respect to metaliferrous components and power production."

This prompted another cable from the pilot:

"Thanks again. It will sure cut my fuel bill."

The same day he finally received a clear message:

"DON'T USE KEROSENE. IT COULD KILL THE ENGINE — AND YOU TOO!"

ing cannot take place unless the foundations for the development of those skills, knowledge or attitudes have been laid by previous education.

**1.4.8** A skill is an organized and co-ordinated pattern of psychomotor, social, linguistic and intellectual activity. Teaching is a skill in its own right, and the possession of a skill in a particular activity does not necessarily indicate skill in teaching that activity to others. This is an important consideration in the selection of flight instructors, check pilots, or anyone connected with a teaching activity.

**1.4.9** Skills, knowledge or attitudes gained in one situation can often be used in another. This is called positive transfer. Negative transfer occurs when previous learning interferes with new learning. It is important to identify the elements of training which can induce negative transfer since a return to earlier learned practices may occur in conditions of stress.

**1.4.10** Learning is an internal process and training is the control of this process. The success or failure of training must be determined by the changes in performance or behaviour which the learning produces. Since learning is accomplished by the student and not by the teacher, the student must be an active rather than a passive participant. Memory is relevant to learning — short-term memory (STM) refers to the storage of information which will be stored and quickly forgotten, while long-term memory (LTM) allows the storage of information for extended periods of time. STM is limited to a few items of information during a few seconds. Through repetition, information is transferred into LTM. While there is a very large capacity in LTM and fewer storage problems, there are certainly retrieval problems, as exemplified by the problems of witness recollections of past events.

**1.4.11** A number of factors can interfere with the success of a training programme — obvious ones like sickness, fatigue or discomfort as well as others like anxiety, low motivation, poor quality instruction, an unsuitable instructor, inadequate learning techniques or inadequate communication.

**1.4.12** It is cost-effective to observe a systems approach to training. Its first step is to determine the training needs, possibly through job task analyses. The second step provides a clear job description and analysis. The objective of the training can then be formulated, and criteria can be established for the selection of the trainees. Next, the course content is determined, and the course implemented. Different methods include: lectures, lessons, discussions, tutorials, audio-visuals, programmed instruction, and computer-based training.

**1.4.13** There are two major types of training devices: training aids (such as slides, videographs, blackboards, wall charts), which help the teacher present a subject and training equipment (such as the flight simulator), which provides for active participation and practice by the trainee. The development of simulators is based on the need to provide practical training in as realistic an environment as possible, at low cost and risk, and with a high degree of efficiency. To obtain approval from certifying authorities, the simulator's fidelity must be high enough to develop the proficiency and performance which are expected in real life situations.

**1.4.14** It is often assumed that to achieve the best training results it is necessary to incorporate the highest degree of fidelity in the training situation. Fidelity is expensive, however, and it should be cost-effective. Motion, control loading, sound and visual systems, and specific equipment simulation (radar — built-in test equipment — flight management computers, etc.) involve considerable expenditure. At the upper limits of simulation, a very small increase in fidelity becomes very expensive — this is especially relevant since available evidence supports the fact that a good return of training transfer is often obtained from moderate levels of fidelity. It is the specialist's task to determine the degree of fidelity needed to meet specific training requirements for a particular situation. High fidelity is required in a training device when the student must learn to make discriminations when selecting switches or controls and where the responses required are difficult to make or critical to the operation. Low fidelity in the equipment is acceptable when procedures are first being learned, in order to avoid confusion and not overload the beginner. As the training progresses, increased fidelity is generally required for user acceptance.

### Leadership

**1.4.15** A leader is a person whose ideas and actions influence the thought and the behaviour of others. Through the use of example and persuasion, and an understanding of the goals and desires of the group, the leader becomes a means of change and influence.

**1.4.16** It is important to establish the difference between leadership, which is acquired, and authority, which is assigned. An optimal situation exists when the two are combined. Leadership involves teamwork, and the quality of a leader depends on the success of the leader's relationship with the team. Leadership skills should be developed for all through proper training; such training is essential in aircraft operations where junior crew members are sometimes called upon to adopt a leadership role





Reprinted from *Air Line Pilot*, April 1988.

throughout the normal performance of their duties. This may occur when the co-pilot must take over from an absent or incapacitated captain, or when a junior flight attendant must control the passengers in a particular cabin section.

**1.4.17** Skilled leadership may be needed to understand and handle various situations. For instance, personality and attitude clashes within a crew complicate the task of a leader and can influence both safety and efficiency. Aircraft accident and incident investigations have demonstrated that personality differences influence the behaviour and performance of crew members. Other situations requiring skilled leadership may be rooted in the frustrations of first officers over slow promotions, or of pilots who are employed as flight engineers.

### Personality and attitudes

**1.4.18** Personality traits and attitudes influence the way we conduct our lives at home and at work. Personality traits are innate or acquired at early stages of life. They are deep-rooted characteristics which define a person, and they are very stable and resistant to change. Traits such as aggression, ambition and dominance may be seen as reflections of personality.

**1.4.19** Attitudes are learned and enduring tendencies or predispositions, more or less predictable, to respond favourably or unfavourably to people, organizations, decisions, etc. An attitude is a predisposition to respond in a certain way; the response is the behaviour itself. It is believed that our attitudes provide some sort of cognitive organization of the world in which we live, allowing us to make rapid decisions on what to do when facing certain situations.

**1.4.20** Accidents have been caused by inadequate performance by people who had the capacity to perform effectively and yet failed to do so. Reports from the Confidential Human Factors Reporting Programme (CHIRP) and the Aviation Safety Reporting System (ASRS) support the view that attitudes and behaviour play a significant role in flight safety. This indicates the need for more research into desirable and undesirable personality characteristics in crew members, and the importance of an effective assessment of personality during crew selection. If personality or attitude differences on the flight deck have indeed been cited as the cause of accidents and incidents, then we should also look at the extent to which it may be possible to influence attitudes through training.

**1.4.21** The difference between personality and attitudes is relevant, because it is unrealistic to expect a

change in personality through routine training, or captaincy or management training. The initial screening and selection process are the place and time to take appropriate action. On the other hand, attitudes are more susceptible to change through training. The effectiveness of the training depends on the strength of the attitude(s) which are to be modified. To this end, some States have demonstrated the safety benefits — particularly for single-pilot operations — of programmes for improving the pilot decision-making process by identifying hazardous thought patterns. Modifying attitudes or behaviour patterns through persuasion is also of direct relevance to safety and efficiency. Crew bulletins, staff notices and advertising are examples of persuasion.

### Communication

**1.4.22** Effective communication, which includes all transfer of information, is essential for the safe operation of flight. The message might be transferred by speech, by the written word, by a variety of symbols and displays (e.g. instruments, CRT, maps) or by non-verbal means such as gestures and body language. The quality and effectiveness of communication is determined by its intelligibility: the degree to which the intended message is understood by the receiver.

**1.4.23** There are several hazards which reduce the quality of communications:

- failures during the transmitting process (e.g. the sending of unclear or ambiguous messages, language problems);
- difficulties caused by the medium of transmission (e.g. background noises or distortion of the information);
- failures during receiving (e.g. the expectation of another message, wrong interpretation of the arriving message or even its disregard);
- failures due to interference between the rational and emotional levels of communication (e.g. arguments);
- physical problems in listening or speaking (e.g. impaired hearing or wearing of the oxygen mask);
- use of English among native and non-native speakers; and
- encoding/decoding/noise.

1.4.24 It is the task of Human Factors training to prevent communication errors. This task includes the explanation of common communication problems as well as the reinforcement of a standard of language to ensure the error-free transmission of a message and its correct interpretation. Ambiguous, misleading, inappropriate or poorly constructed communication, combined with expectancy, have been listed as elements of many accidents, the most notorious one being the double B747 disaster in Tenerife (March 1977).

#### Crew co-ordination

1.4.25 Crew co-ordination is the advantage of teamwork over a collection of highly skilled individuals. Its prominent benefits are:

- an increase in safety by redundancy to detect and remedy individual errors; and
- an increase in efficiency by the organized use of all existing resources, which improves the in-flight management.

1.4.26 The basic variables determining the extent of crew co-ordination are the attitudes, motivation and training of the team members. Especially under stress (physical, emotional or managerial), there is a high risk that crew co-ordination will break down. The results are a decrease in communication (marginal or no exchange of information), an increase in errors (e.g. wrong decisions) and a lower probability of correcting deviations either from standard operating procedures or the desired flight path. Additionally, emotional conflicts in the cockpit may result.

1.4.27 The high risks associated with a breakdown of crew co-ordination show the urgent need for Crew Resource Management training, discussed in Part 2 of the manual. This kind of training ensures that:

- the pilot has the maximum capacity for the primary task of flying the aircraft and making decisions;
- the workload is equally distributed among the crew members, so that excessive workload for any individual is avoided; and
- a co-ordinated co-operation — including the exchange of information, the support of fellow crew members and the monitoring of each other's performance — will be maintained under both normal and abnormal conditions.

#### Motivation

1.4.28 Motivation reflects the difference between what a person can do and actually will do, and is what drives or induces a person to behave in a particular fashion. Clearly, people are different and driven by different motivational forces. Even when selection, training and checking ensure capability to perform, it is motivation that determines whether a person will do so in a given situation.

1.4.29 There is a relationship between expectancy and reward as motivators, since the utility of a reward and the subjective probability of its achievement determine the level of effort which will be applied to obtain the reward. This effort must be accompanied by the proper skills. It is important for high performers to see that they are in a better position than poor performers to achieve a reward, otherwise motivation may decline. Job satisfaction motivates people to higher performance.

1.4.30 Modifying behaviour and performance through rewards is called positive reinforcement; discouraging undesirable behaviour by use of penalties or punishment is called negative reinforcement. Even though positive reinforcement can be more effective in improving performance, both must be available to management. Different responses are to be expected from different individuals in relation to positive and negative reinforcers. Care should be taken not to generate an effect which is opposite from that which is intended.

#### Documentation

1.4.31 Inadequacies in aviation documentation have a twofold impact: there is a monetary aspect associated with increased time or the impossibility of performing a particular task and there is also a safety aspect. With reference to documentation — including electronic flight documentation displayed on screen — some basic aspects require Human Factors optimization:

- a) written language, which involves not only vocabulary and grammar, but also the manner in which they are used;
- b) typography, including the form of letters and printing and the layout, has a significant impact on the comprehension of the written material;
- c) the use of photograph diagrams, charts or tables replacing long descriptive text is advantageous to help comprehension and maintain interest. The use of colour in illustrations reduces the discrimination workload and has a motivational effect;



- d) the working environment in which the document is going to be used has to be considered when print and page size are determined (for example, an airport chart which is too small may induce error during taxiing).

### Workstation design

1.4.32 For design purposes, the flight deck should be considered as a system, as opposed to a collection of particular aspects or systems such as hydraulic, electrical or pressurization. Expertise should be applied towards matching the characteristics of these systems to those of humans, with due consideration to the job to be performed. Proper matching of working areas to human dimensions and characteristics is important — for instance, size, shape and movements of the body provide data used to ensure adequate visibility in the flight deck, location and design of controls and displays, and seat design.

1.4.33 The importance of the standardization of panel layout relates to safety, since there are numerous reports of errors arising from inconsistent panel layouts, involving inadvertent reversion to an operating practice appropriate to an aircraft flown previously. Seat design considerations include seat controls, headrests, seat cushion and fabric, lumbar support, thigh support, etc.

1.4.34 A display is any means of presenting information directly to the operator. Displays use the visual, aural or tactile senses. The transfer of information from a display to the brain requires that information is filtered, stored and processed, a requirement which can cause problems. This is a major consideration in the design of flight deck displays. The information should be presented in such a way as to assist the processing task, not only under normal circumstances, but also when performance is impaired by stress or fatigue.

1.4.35 A fundamental consideration in display design is to determine how, in what circumstances, and by whom the display is going to be used. Other considerations include the characteristics of visual displays and aural signals; light requirements; the selection of analogue or digital alternatives; the applicability of LEDs (light-emitting diodes), LCDs (liquid-crystal displays) and CRTs (cathode-ray tubes); the angle at which the display is to be viewed and its related parallax; viewing distance, and possible ambiguity of the information.

1.4.36 Three fundamental operational objectives apply to the design of warning, alerting and advisory systems: they should alert the crew and draw their attention, report the nature of the condition, and, when poss-

ible, guide them to the appropriate corrective action. System reliability is vital, since credibility will be lost if false warnings proliferate, as was the case with earlier generations of ground proximity warning systems. In the event of a technical failure of the display system, the user should not be presented with unreliable information. Such information must be removed from sight or clearly flagged. For example, unreliable flight director command bars should disappear. Invalid guidance information which remained on display has been a factor in accidents.

1.4.37 A control is a means of transmitting discrete or continuous information or energy from the operator to some device or system. Control devices include push buttons, toggle or rotary switches, detented levers, rotary knobs, thumbs wheels, small levers or cranks and keypads. The type of device to be used depends on functional requirements and the manipulation force required. Several design features apply to controls:

- a) location;
- b) control-display ratio (control movement related to that of the moving element of the associated display);
- c) direction of movement of the control relative to the display;
- d) control resistance;
- e) control coding, by means of shape, size, colour, labelling and location; and
- f) protection against inadvertent actuation.

1.4.38 The application of automation to flight deck displays and controls may breed complacency and over-reliance on the automated system, which have been suggested as factors in accidents and incidents. If the Human Factors-related issues (e.g. the limited performance of the human as monitor and effects on motivation) are properly addressed, there may be a justification for automation. It may contribute to improved aircraft and system performance and over-all efficiency of the operation. It may relieve the crew of certain tasks so as to reduce workload in phases of flight where it reaches the limit of operational acceptability.

### Cabin design

1.4.39 Human Factors considerations for the cabin include aspects of workspace and layout as well as information on human behaviour and performance.

**1.4.40** Human size and shape are relevant in the design of cabin equipment (toilets, galleys, meal carts and overhead bins); emergency equipment design (life-jackets, life-rafts, emergency exits, oxygen masks); seats and furnishings (including in-flight entertainment); jump seats and rear-facing seats. Knowledge of the user's height and reach determines location of equipment and controls. Proper access and room to work must be provided in cargo compartments. The estimation of human forces required to operate doors, hatches and cargo equipment have to be realistic. Anthropometry (the study of human dimensions) and biomechanics (study of the movement of parts of the body and the forces which they can apply) are the sources of the required information for those purposes.

**1.4.41** Due consideration has to be given to handling special passengers: the physically handicapped, the intoxicated, and the fearful. Passenger behaviour, including group influences, and expected human behaviour when facing a crisis are of relevance here.

**1.4.42** Recent accidents and incidents have documented the need for Human Factors information for those involved in ground operations, such as maintenance and inspection managers, flight line supervisors and others. Similarly, persons involved in the design of aircraft systems should recognize human limits in maintaining, inspecting and servicing aircraft. Such factors as training, work environment, communication methods, physiological limitations and human engineering of equipment should be considered.

#### Visual performance and collision avoidance

**1.4.43** A proper understanding of how the visual system works helps in the determination of optimum working conditions. The characteristics and measurement of light, the perception of colour, the physiology of the eyes and the way the visual system works are relevant in this area. Also important are factors involved in the ability to detect other aircraft at a distance, either in daytime or at night, or to identify outside objects in the presence of rain or other contamination on the windscreen.

**1.4.44** Visual illusions and disorientation in flight operations may be directly related to safety. During all phases of flight, but in particular during approach and landing, visual illusions are believed to have played a significant role in accidents for which it is difficult to find any other explanation. Factors of specific consideration here include sloping terrain, runway width, lighting intensity, the "black hole" phenomenon and lack of runway texture. An effective step in reducing the risks

associated with visual illusions in flight operations is the recognition through training that visual illusions are a natural phenomenon. Training should also help in understanding that the circumstances in which they occur are often predictable. The use of additional information sources to supplement visual cues (radar, attitude displays, radio altimeters, VASIs, DMEs, etc.) is the most effective protective measure against disorientation and illusions. To some extent the risk from visual illusions may be alleviated by design features such as high optical quality windshield glass, adequate visibility, eye position guidance, effective windshield rain and ice protection, etc.

#### LIST OF REFERENCES

##### Journals

*Ergonomics*; United Kingdom; Taylor and Francis; monthly; official journal of the International Ergonomics Association and Ergonomics Society.

*Human Factors*; United States; Human Factors and Ergonomics Society; quarterly, the journal of the Human Factors and Ergonomics Society.

*The International Journal of Aviation Psychology*; United States; quarterly, Lawrence Erlbaum Associates, Hillsdale, New York.

##### Bulletins

*Cabin Crew Safety Bulletin*; Flight Safety Foundation; United States; bi-monthly.

*Human Factors Bulletin*; Flight Safety Foundation; United States; periodically.

##### Incident reporting systems

*Callback*; United States; NASA-Ames; monthly; bulletin of the ASRS.

*ARSR Quarterly Reports*; United States; NASA-Ames; quarterly; summaries and analyses.

*ASRS Contractor Reports*; United States; NASA-Ames; periodically; ASRS data analyses.

*Feedback*; United Kingdom; Institute of Aviation Medicine; trimonthly; bulletin of the CHIRP.

##### Books — Recommended reading

Campbell, R.D., and M. Bagshaw. *Human performance and limitations in aviation*. BSP Professional Books.

Green, R.G., H. Muir, M. James, D. Gradwell, and R.L. Green, *Human Factors for pilots*. Averbury Technical.

- Hawkins, Frank H. *Human Factors in Flight*. Gower.
- Hurst R., and Hurst L.R. (eds.). *Pilot Error* (2nd ed.). Granada.
- Jensen, R.S. (ed.). *Aviation Psychology*. Gower.
- Jensen, R.S. *Pilot Judgement and Crew Resource Management*. Averbury Aviation.
- Johnston, A.N., N. McDonald, and R. Fuller (eds.). *Aviation Psychology in Practice*. Averbury Technical.
- Johnston, A.N., N. McDonald, and R. Fuller, (eds.). *Applications of Psychology to the Aviation System*. Averbury Aviation.
- Johnston, A.N., N. McDonald, and R. Fuller, (eds.). *Aviation Psychology: Training and Selection*. Averbury Aviation.
- Johnston, A.N., N. McDonald, and R. Fuller, (eds.). *Human Factors in Aviation Operations*. Averbury Aviation.
- Maurino, D., J. Reason, N. Jonston, and R. Lee. *Beyond Aviation Human Factors*. Averbury Aviation.
- Nance, J.J. *Blind Trust: The Human Factors of Air line Accidents*; Morrow.
- O'Hare, D., and S. Roscoe. *Flightdeck performance: The Human Factors*. Iowa State University Press.
- Reason, J., and K. Mycielska. *Absent Minded*; Prentice-Hall.
- Reason, J. *Human error*. Cambridge University Press.
- Sloan, S.J., and C.L. Cooper. *Pilots under stress*. Routledge & Kegan Paul.
- Telfer, Ross A. *Aviation Instruction and Training*. Ashgate.
- Trollip, S.R., and R.S. Jensen. *Human Factors for general aviation*. Jeppesen Sanderson Inc.
- Wiener, E.L., B.G. Kanki, and R.L. Helmreich, (eds.) *Cockpit Resource Management*; Academic Press.
- Wiener, Earl, and David C. Nagel. *Human Factors in Aviation*. Academic.
-

## CHAPTER 2

# HUMAN FACTORS, MANAGEMENT AND ORGANIZATION

### 2.1 INTRODUCTION

2.1.1 Since the beginning of aviation, human error has been recognized as a major factor in accidents and incidents. Indeed, one of aviation's biggest challenges has been — and will continue to be — human error avoidance and control. Traditionally, human error in aviation has been closely related to operational personnel, such as pilots, controllers, mechanics, dispatchers, etc. Contemporary safety views argue for a broadened perspective which focuses on safety deficiencies in the system rather than in individual performance. Evidence provided by analysis from this perspective has allowed the identification of managerial deficiencies at all operating stages of the aviation system as important contributing factors to accidents and incidents.

2.1.2 During the early years, aviation safety efforts were directed towards improving the technology, with the main focus on operational and engineering methods for combating hazards. With admirable success, they sustained a reduced accident rate. When it became apparent that human error was capable of circumventing even the most advanced safety devices, efforts were then directed to the human element in the system. The late 70s and 80s will undoubtedly be remembered for the prevailing enthusiasm regarding aviation Human Factors. Cockpit (and then Crew) Resource Management (CRM), Line-Oriented Flight Training (LOFT), Human Factors training programmes, attitude-development programmes and similar efforts have multiplied, and a campaign to increase the awareness of the pervasiveness of human error in aviation safety has been initiated. Human error, however, continues to be at the forefront of accident statistics.

2.1.3 Statistics can be misleading in understanding the nature of accidents and devising prevention measures. Statistics reflect accidents as a series of cause and effect relationships grouped into discrete categories (flight crew, maintenance, weather, ATC, etc.). Errors are not registered as such but some of their effects are: controlled flight into terrain, aborted take-off overrun, etc. Statistics then provide the answers when it is too late. They fail to reveal

accidents as *processes*, with multiple interacting chains, which often go back over considerable periods of time and involve many different components of the over-all system.

2.1.4 The investigation of major catastrophes in large-scale, high-technology systems has revealed these accidents to have been caused by a combination of many factors, whose origins could be found in the lack of Human Factors considerations during the design and operating stages of the system rather than in operational personnel error. Examples of such catastrophes include the accidents at the Three Mile Island (Pennsylvania, USA, 28 March 1979) and Chernobyl (Ukraine, USSR, 26 April 1986) nuclear power plants, the Challenger space shuttle (Florida, USA, 28 January 1986), the double B-747 disaster at Tenerife (Canary Islands, Spain, 27 March 1977) and the Bhopal (Bhopal, India, 3 December 1984) chemical plant. Large-scale, high-technology systems like nuclear power generation and aviation have been called *sociotechnical systems*, in reference to the complex interactions between their human and technological components. *Management factors* and *organizational accidents* are key concepts in sociotechnical systems' safety. The terms *system accident* and *organizational accident* reflect the fact that certain inherent characteristics of sociotechnical systems, such as their complexity and the unexpected interaction of multiple failures, will inevitably produce safety breakdowns. In sociotechnical systems, remedial action based on safety findings goes beyond those who had the last opportunity to prevent the accident, i.e. the operational personnel, to include the influence of the designers and managers, as well as the structure or architecture of the system. In this approach, the objective is to find *what*, rather than *who*, is wrong.

2.1.5 Consider the probable cause statement in the aircraft accident report following a twin jetliner crash during an attempted take-off in icing conditions:

"The National Transportation Safety Board determines that the probable causes of this accident were the failure of the airline industry and the Federal Aviation Administration to provide flight crews with proced-



failure of the airline industry and the Federal Aviation Administration to provide flight crews with procedures, requirements and criteria compatible with departure delays in conditions conducive to airframe icing and the decision by the flight crew to take off without positive assurance that the airplane wings were free of ice accumulation after 35 minutes of exposure to precipitation following deicing. The ice contamination on the wings resulted in an aerodynamic stall and loss of control after liftoff. Contributing to the cause of the accident were the inappropriate procedures used by, and inadequate coordination between, the flight crew that led to a rotation at a lower than prescribed airspeed.”<sup>1</sup>

While acknowledging the role the operational personnel played in triggering the accident, the analysis looks for system deficiencies and recognizes that the root causes of the accident can be traced back to flaws in the aviation system design and operation.

**2.1.6** This chapter, therefore, addresses the influence of management factors in aviation safety, from the perspective of organizational accidents. Its contents, like any changes or new approaches in aviation, are *evolutionary* rather than *revolutionary*. Management factors in accident prevention go back to some of the earliest industrial safety texts, forty or more years ago; they have been the subject of prevention courses for over thirty years (*Advanced Safety Management and System Safety Factors*, C.O. Miller, University of Southern California, 1965). The objective of this chapter is to provide the participants in the decision-making process in the aviation industry — including corporate management, regulatory authorities, manufacturers and professional associations — with an awareness of the impact of their actions or inactions on aviation safety. Throughout the chapter, numerous examples are included for clarification purposes. The examples are excerpted from accident investigation reports produced by relatively few States and their inclusion should by no means be construed as a negative reflection on the safety record of those States or as an unwarranted criticism of their administrations or aviation systems. On the contrary, it is an implicit recognition of a progressive attitude towards safety, since by virtue of being pioneers in the application of the perspective advanced by this chapter, those States are among those at the leading edge of the international community’s safety endeavours.

**2.1.7** This chapter comprises the following:

- an introduction to contemporary safety thinking, presenting the shift from individuals to organizations.
- examples of how system deficiencies whose roots can be found far away from the site contribute to accidents and introduces the concept of safe and unsafe organizations.
- a “how to” to help decision-makers recognize why they should act upon safety; it provides details on and examples of what decision-makers can do to contribute to safety.

## 2.2 FROM INDIVIDUALS TO ORGANIZATIONS

“At 01:24 on Saturday, 26 April 1986, two explosions blew off the 1000-tonne concrete cap sealing the Chernobyl-4 reactor, releasing molten core fragments into the immediate vicinity and fission products into the atmosphere. This was the worst accident in the history of commercial nuclear power generation. It has so far cost over 30 lives, contaminated some 400 square miles of land around the Ukrainian plant, and significantly increased the risk of cancer deaths over a wide area of Scandinavia and Western Europe ... There are two immediate questions: (1) How and why did a group of well-intentioned, highly motivated and (by other accounts at least) competent operators commit just the right blend of errors and safety violations necessary to blow this apparently safe reactor? (2) Could something like it happen here?”<sup>2</sup>

**2.2.1** The first step in answering these questions is recognizing that operational personnel do not act in isolation, but plan and execute their actions within a social milieu. They are part of an *organization* and, functioning on a continuous basis and through a division of labour and a hierarchy of authority, seek to achieve an objective or a set of objectives.<sup>3</sup> Operational personnel are *organized*, which implies the existence of task distribution, co-ordination, synchronization, shared objectives and acceptance of a common authority. Furthermore, operational personnel do not operate in a vacuum. Their actions and attitudes are a reflection on those who employ and represent them. For example, an attitude of disrespect for the disciplined application of procedures does not develop overnight; it develops after prolonged exposure to an atmosphere of indifference.<sup>4</sup>

**2.2.2** The second step involves the recognition that during the second half of the twentieth century, large-scale, technically-based systems and organizations have become firmly established during what is sometimes called the “second industrial revolution”.<sup>5</sup> The term *socio-technical systems*, coined in 1960, refers to organizations

which use high technology on a large scale. The aerospace industry, nuclear power generation, marine and railroad transportation and the chemical processing industry are examples of sociotechnical systems. The organizations in these systems bring together two components to achieve their objectives: the technical component (technology) and the human component (people). These two components interact with each other at every human-machine interface. Both components are highly interdependent and operate under *joint causation*; that is, both humans and machines are affected by the *same* causal events in their surrounding environment.<sup>6</sup> Organizations in sociotechnical systems pursue *production goals*: transportation of people and goods in aerospace, marine and railroad systems; energy in nuclear power generation, etc. It is characteristic that the consequences of safety breakdowns in organizations within sociotechnical systems are catastrophic in terms of loss of life and property, since they involve high-risk/high-hazard activities. Likewise, in large-scale technological systems, potential hazards are concentrated in single sites under the centralized control of relatively few operational personnel: the control room operators in a nuclear power plant; the flight crew in an aircraft, etc.<sup>7</sup> Within the aviation system, organizations include airlines and other operators, manufacturers, airports, air traffic control, weather services, civil aviation authorities, safety investigation agencies, international organizations (ICAO, JAA, EUROCONTROL, etc.) and professional associations (IATA, IFALPA, IFATCA, ISASI, etc.).

2.2.3 As a consequence of the close interdependence between people and technology, complex and often-overlooked changes in sociotechnical systems may occur over time. Therefore, when pursuing safety in these systems, it is narrow and restrictive to look for explanations for accidents or safety deficiencies in exclusively technical terms or purely from the perspective of the behavioural sciences, i.e. human error. Analysis of major accidents in technological systems has clearly indicated that the preconditions to disasters can be traced back to identifiable organizational deficiencies. It is typical to find that a number of undesirable events, all of which may contribute to an accident, define an "incubation period" which is often measured in terms of years, until a trigger event, such as an abnormal operating condition, precipitates a disaster. Furthermore, accident prevention activities in sociotechnical systems recognize that major safety problems do not belong exclusively to either the human or the technical components. Rather, they emerge from as yet little understood interactions between people and technology<sup>8</sup>. The environment in which these interactions take place further influences their complexity.

2.2.4 With these basic concepts at hand, let us attempt to marry theory to practice and answer the ques-

tions in 1.1. When viewed from the perspective of socio-technical systems' safety, it is obvious the ingredients for the Chernobyl disaster were present at many levels. There was a *society* committed to the production of energy through large-scale power plants; there was a *system* that was complex (i.e. with many control parameters that could potentially interact), potentially hazardous, tightly coupled (i.e. with relatively few ways of achieving particular goals), opaque (i.e. with many unfamiliar or unintended feedback loops) and operating in borderline conditions; there was a *management structure* that was monolithic, remote and slow to respond; and there were *operators* who possessed only a limited understanding of the interdependences of the system they were controlling and who, in any case, were assigned a task that made violations inevitable<sup>9</sup>. These factors are not unique to any particular State or to nuclear power generation. By substituting a few terms, the description becomes a framework applicable to aviation accidents anywhere in the world aviation community, as the following example illustrates.

2.2.5 On 1 February 1991, a Boeing 737 collided with a SA-227-AC (Fairchild Metroliner) while the 737 was landing on runway 24 left at Los Angeles International Airport (*a society committed to the production of large-scale, high-technology transportation*). The Metroliner was positioned on the runway, at an intersection, awaiting clearance for take-off. The glare from the apron lighting made the aircraft inconspicuous and difficult to see from the control tower (*system operating in borderline conditions*). Both aircraft were destroyed and 34 persons fatally injured. The probable cause statement reads as follows (text in italics added):

"The National Transportation Safety Board determines that the probable cause of the accident was the failure of the Los Angeles Air Traffic Facility Management to implement procedures that provided redundancy comparable to the requirements contained in the National Operational Position Standards and the failure of the FAA Air Traffic Service to provide adequate policy direction and oversight to its air traffic control facility managers [*management structure slow to respond*]. These failures created an environment in the Los Angeles Air Traffic Control tower that ultimately led to the failure of the local controller 2 (LC2) to maintain an awareness of the traffic situation, culminating in the inappropriate clearances and subsequent collision ... [*operator with a limited understanding of the system she was controlling and set to a task that made violations inevitable; system opaque*]. Contributing to the accident was the failure of the FAA to provide effective quality assurance of the ATC system [*management structure slow to respond; system tightly-coupled, hazardous, complex*]."<sup>10</sup>

**2.2.6** This analysis takes into consideration all the components described in the previous paragraphs. It looks into the human and technical elements, recognizing their interdependence and interaction, thus observing the principle of joint causation. It goes beyond — although it does not ignore — the actions of the operational personnel (the air traffic controller and the pilots). It acknowledges that operational personnel do not operate in isolation and it looks into the organizational deficiencies and management factors involved in the “incubation period” of the accident. In this broadened view, system safety deficiencies are crystal clear, as are the remedial actions necessary to correct them. Most importantly, by determining *why* the accident occurred, it indicates *what* is wrong in the system and should be corrected rather than *who* made a mistake and should be punished. Blame and punishment have, in themselves, limited value as prevention tools.

**2.2.7** On 10 March 1989, a Fokker F-28 Mk-1000 crashed after take-off from Dryden Municipal Airport in Dryden, Ontario, Canada. A total of 24 persons died as a consequence of the crash and the accompanying fire. The final report of the Commission of Inquiry recognizes that take-off was attempted with snow and ice contaminating the wings, a fact which eventually led to the accident. However, in keeping with a system analysis, the report poses a fundamental question: what caused or prompted the pilot-in-command to make the decision to take off; and what system safeguards should have prevented or altered this decision? It further states:

“... The pilot-in-command made a flawed decision, but that decision was not made in isolation. It was made in the context of an integrated air transportation system that, if it had been functioning properly, should have prevented the decision to take off ... there were significant failures, most of them beyond the captain’s control, that had an operational impact on the events in Dryden ... the regulatory, organizational, physical and crew components must be examined to determine how each may have influenced the captain’s decision.”

The results of this examination are summarized in the report as follows:

“... the captain, as pilot-in-command, must bear responsibility for the decision to land and take off in Dryden on the day in question. However, it is equally clear that the air transportation system failed him by allowing him to be placed in a situation where he did not have all the necessary tools that should have supported him in making the proper decision.”<sup>11</sup>

**2.2.8** Again, all elements have been considered. This approach also puts into perspective who is in the best

position to undertake remedial actions, i.e. who can provide the greatest contribution to safety. Had they survived, the flight crew could have improved their future performance as the last safety valve in the system through increased training and re-certification, personal improvement, etc. Focusing remedial action around improved performance by this particular crew would enhance safety at the individual level, that is, only as far as this crew is concerned. However, the door would remain open for many other flight crews operating in the same unimproved system to make errors invited by imperfect system design. The major contribution must then originate at the decision-making levels, those who have the ultimate power to introduce radical changes and modify — system-wide — the architecture, design and operation of the system.

**2.2.9** In general terms, there are three levels of action decision-makers can choose in pursuing the safety recommendations from analyses such as those exemplified in the previous paragraphs:<sup>12</sup>

- The first level of action is to eliminate the hazard, thereby preventing a future accident. In the case of the runway collision accident, for example, a decision could be made that in airports having parallel runways, one runway should be used for take-offs and the other for landings. In the icing example, it could be decided to absolutely forbid operations when conditions are conducive to airframe icing. These are the safest decisions but they may not be the most efficient.
- The second level of action is to accept the hazard identified and adjust the system to tolerate human error and to reduce the possibility of an occurrence. In this context, the decisions following the Los Angeles accident might include eliminating night intersection take-offs or clearances involving taxiing into position on an active runway and holding for take-off clearance. In the Dryden example, the decision might be to eliminate operations into stations without proper de-icing facilities, or when aircraft equipment related to anti-icing protection is unserviceable, in environmental conditions conducive to icing. Although not as safe as first level actions, these options are more realistic and efficient and they work.
- The third level of action involves both accepting that the hazard can be neither eliminated (level one) nor controlled (level two) and teaching operational personnel to live with it. Typical actions include changes in personnel selection, training, supervision, staffing and evaluation,

increasing or adding warnings, and any other modifications which could prevent operational personnel from making a similar mistake.

Third level actions should not be taken in preference to first or second level actions, since it is impossible to anticipate all future kinds of human error. Attempting to eliminate all human error is an unattainable goal, since error is a normal part of human behaviour. The total system (including aircraft, crew, airports and ATC) should identify, tolerate and correct human error. *Tolerate* is the key word; as long as humans are involved, the system must be designed to tolerate the entire range of "normal" human behaviour, including human weaknesses. It must be error-tolerant.

2.2.10 On Monday, 12 December 1988, a commuter train was approaching Clapham Junction station (England) when it crossed a signal which suddenly turned red. The driver, in accordance with standard operational procedures, stopped the train and went to phone the signal box to report that he had crossed a signal at "danger". During his absence, the signal turned from red to yellow as a result of faulty rewiring work performed by a technician two weeks earlier. This allowed another commuter train to enter the same track and crash into the back of the stationary train. Thirty-five people died and nearly 500 were injured, 69 of them seriously. The Report of the Investigation into the Clapham Junction Railway Accident states:

"The vital importance of [the] concept of absolute safety was acknowledged time and again in the evidence that the Court heard [from the railway company management]. The problem with such expressions of concern for safety was that the remainder of the evidence demonstrated beyond dispute two things:

- (i) there was total sincerity on the part of all who spoke of safety in this way but nevertheless
- (ii) there was a failure to carry those beliefs through from thought to deed.

The appearance was not the reality. The concern for safety was permitted to co-exist with working practices which ... were positively dangerous. This unhappy co-existence was never detected by management and so the bad practices never eradicated. The best of intentions regarding safe working practices was permitted to go hand in hand with the worst of inaction in ensuring that such practices were put into effect.

The evidence therefore showed the sincerity of the concern for safety. Sadly, however, it also showed the

reality of the failure to carry that concern through into action. It has been said that a concern for safety which is sincerely held and expressly repeated but, nevertheless, is not carried through into action, is as much protection from danger as no concern at all."

Adhering to the notion of accident causation in socio-technical systems, the Report concludes:

"[The railway company management] commitment to safety is unequivocal. The accident and its causes have shown that bad workmanship, poor supervision and poor management combined to undermine that commitment".<sup>13</sup>

2.2.11 The message underlying the foregoing is twofold. Firstly, it should be obvious that manifestations of intent like the well-known truism "*safety is everybody's business*" are not enough; decision-makers have to adopt an active stance in promoting safety action.<sup>14</sup> Indeed, it is asserted that management participation in safety deficiencies prevention is an everyday commitment and safety promotion by decision-makers requires as active an involvement as that of the operational personnel. Secondly, it would be misleading and quite unfair to suggest that decision-makers are not interested in or neglect safety promotion. The Clapham report exemplifies that, beyond any reasonable doubt, concern for safety ranks high in decision-makers' thoughts. Why the failure in carrying thought into deed, as evidenced by accident investigations from the organizational perspective? One answer may be *because of lack of awareness*. Those at the decision-making levels may not be aware of how and why their actions or inactions may affect safety; and even if they are aware, they might not know what to do to actively participate in safety promotion endeavours. If you are unaware of a problem, then for all practical purposes that problem does not exist. Should this contention about lack of awareness be true, it follows that decision-makers need the tools and knowledge to discharge their responsibility. This chapter is but one attempt in that direction.

2.2.12 In filing a dissenting statement to the probable cause stated in the accident report following the runway collision between a Boeing 727 and a Beechcraft King Air A100, one of the members of the investigating agency asserted:

"I also disagree with the notion that agencies cause accidents. Failure of people and failures of equipment cause accidents. Shifting the cause from people to agencies blurs and diffuses the individual accountability that I believe is critically important in the operation and maintenance of the transportation system".<sup>15</sup>

2.2.13 This assertion reflects a real and valid concern, as well as a somewhat widespread misconception. There are some who fear that when exploring the relationship between Human Factors, management and organization — and how it influences aviation safety and effectiveness — the notion of individual accountability may be lost. Others contend that this may also be a subtle way of “passing the buck” for safety entirely to management. In fact, the concept of organizational accidents represents a broadened view of system safety, which does not intend either to shift responsibility or blame from operational personnel towards management, or to remove individual responsibility. Firstly, as already stated, blame is a social and psychological process which involves self-preservation and denial and has only limited safety or prevention value. Secondly, it is not suggested that operational personnel do not make uncalled-for errors; that they sometimes do is beyond doubt. The contention is that the potential for these errors has long been realized and measures to mitigate them are reasonably well recognized. What has been rather neglected are measures directed at enhancing the system’s tolerance to human failures committed — by the simple fact that they are human beings subject to human biases and limitations — by those at the decision-making levels of the aviation system. In the past, limiting prevention endeavours to the flight deck, the ATC workstation, the maintenance shop or any of the other human-system interfaces has proved to be successful in making aviation the safest mode of massive transportation. In the present *and* the future, such an approach may turn out to be of limited safety value and, perhaps, futile.

### 2.3 SAFE AND UNSAFE ORGANIZATIONS

2.3.1 Over time, researchers and academics studying organizations have resorted to a metaphor to assist their endeavours: they have compared organizations to living organisms, notably the human being. Organizations are viewed like complex living structures, with brain, body, personality and objectives. Like human beings, organizations struggle for survival within a constantly changing environment.<sup>16</sup> Within organizational literature, it is a basic premise that “... organizations think. Like individuals, they exhibit a consciousness, a memory, an ability to create and solve problems. Their thinking strongly affects the generation and elimination of hazards.”<sup>17</sup> In this comparison, the managers and decision-makers become the brain; the hierarchies, departments and other permanent structures (including the workforce) become the body; and corporate culture becomes the personality. Traditional Human Factors endeavours have focused on the brain, body and personality of human beings and their inter-

actions with the surrounding environment. The purpose is to either foster safe behaviour or discourage unsafe behaviour and thus improve safety and efficiency as well as the well-being of those in the aviation system. Human Factors ideas and techniques can also be applied to organizations. This chapter borrows from the organism metaphor and discusses the equivalent components of brain, body, personality and objectives as they apply to organizations. Thus the characteristics of safe and unsafe organizations and organizational behaviour can be considered as yet another contribution to the pursuit of safety, efficiency and individual well-being within the aviation system. The world-wide survey conducted in 1986 by a major aircraft manufacturer (discussed in 2.5.1 and 2.5.2) attests to the relevance of the concept of safe and unsafe organizations.

2.3.2 Organizations have *objectives* which are usually related to production: building aircraft or other equipment, transporting passengers, transporting goods, etc. Producing profit for stockholders is one of the goals of many organizations. Most organizations within the aviation industry are formed to achieve some practical objective or goal, *and safety is not the primary goal*. Safety fits into the objectives of organizations, but in a supporting role, to achieve the production objectives safely, i.e. without harm to human life or damage to property.<sup>18</sup> Therefore, before discussing safe and unsafe organizations, it is essential to put safety into perspective and decide where it fits within the objectives of aviation organizations. From an organizational perspective, safety should be seen as a method of conserving all forms of resources, including controlling costs. Safety allows organizations to pursue their production objectives with minimum damage to equipment or injury to personnel. It assists management in achieving this objective with the least risk.<sup>19</sup> There is an element of risk in aviation that cannot be eliminated, but it can be successfully controlled through risk management programmes directed at correcting safety deficiencies before an accident occurs. These programmes are an essential tool for decision-makers to formulate decisions on risk and to contribute to safety while pursuing the production goals of their organizations.<sup>20</sup> Basic risk management concepts are included in the *Accident Prevention Manual* (Doc 9422) and are further discussed in 2.5.5.

#### Corporate Culture

2.3.3 *Corporate culture* is as relevant to organizational performance as personality is to human behaviour. On 4 March 1987, a CASA C-212-C crashed just inside the threshold of Runway 21R at Detroit Metropolitan Airport, Michigan, USA, killing 9 of the 19 persons on board. The probable cause statement indicates

that the captain was unable to control the aeroplane while attempting to recover from an asymmetric power condition at low speed following his intentional use of reverse thrust (beta mode) of propeller operation to descend and slow the aeroplane rapidly on final approach for landing. This procedure was strictly forbidden by both the aircraft flight manual and company operating procedures. The investigation also disclosed that this was not the first time this captain — by all other accounts an able and competent airman — had resorted to this procedure. Several questions immediately arise:

- If company procedures were clearly stated, why were they not followed by this captain?
- If use of beta mode in flight was strictly forbidden and this captain [frequently] ignored this instruction, what prevented other pilots who witnessed this captain ignoring that order from bringing the fact to the attention of the company?
- If use of beta mode in flight was forbidden by the flight manual, why was it available to flight crews?
- Why was this captain's disregard for company procedures and the aircraft flight manual not exposed before it was discovered following an accident?
- Lastly, if the company knew about the flying habits of this captain, would they — and could they — have taken any action?<sup>21</sup>

2.3.4 The Final Report of the Commission of Inquiry into the Air Ontario Crash at Dryden, Ontario, in its in-depth discussion of how corporate culture played a significant role in this accident, suggests an answer to these questions:

“... even in organizations with a strong commitment to standardization ... informal subcultures frequently tolerate or encourage practices which are at variance with organizational policies or regulatory standards ... Evidence of procedural variance is found in several reported practices ... these suggest that the [corporate] culture may have allowed crews considerable leeway in making decisions about whether to take-off with surface contamination ... a practice which, unfortunately, was not unequivocally proscribed by the then current [civil aviation authority] regulations ...”<sup>22</sup>

The inevitable questions then arise: What is culture? Can decision-makers influence corporate culture? If so, what can decision-makers do to influence it?

2.3.5 Culture refers to beliefs and values which are shared by all or almost all members of a group. Culture shapes behaviour and structures a person's percep-

tion of the world. In that sense, culture is a collective mental programming which distinguishes one human group from another. Culture defines the values and predisposes attitudes, exerting a final influence on the behaviour of a particular group. Norms are the most common and acceptable patterns of values, attitudes and behaviour for a group. Norms are enforced by expressing disapproval of wrongdoers; how strongly a culture sanctions those who violate norms is an indication of the importance attached to those norms. For years people have thought that organizations were beyond the influence of culture and were only influenced by the technologies they utilize or the tasks they pursue. Research has demonstrated, however, that culture deeply influences organizational behaviour.<sup>23,24</sup> If an organization attempts to impart values or behaviours which are in contrast with existing organizational/corporate culture or which are perceived to be in contrast with corporate goals, achieving these values or behaviours will either take considerable time and effort or be impossible altogether. A corporate culture may also allow or prevent violations, since they take place in situations where the shared values of individuals and the group favour certain behaviours or attitudes. In the simplest terms, a group will meet whatever norms are established for an organization and will do whatever it *thinks or perceives* management really wants.

2.3.6 The explanation of the seemingly undisciplined behaviour of the captain involved in the Detroit accident must be sought in the existence of a corporate culture which condoned such practices and in the absence of norms which condemned them. This is best evidenced by the silence surrounding this captain's observed deviations from established procedures. An attitude of disregard of organizational policies or regulatory standards involves more than Human Factors related to the cockpit, since it does not develop overnight. Fast, time-saving, “efficient” approaches — resorting to whatever means necessary to accomplish them — must undoubtedly have been an accepted norm in the operational subculture of the organization. No disapproval can have been explicitly expressed to observed transgressions and thus, over time, such behaviour became a collective mental programming, which fostered this and probably other risk-taking attitudes in pursuing organizational objectives. Ultimately, based upon experience obtained during the term of employment, pilots came to perceive such attitudes and behaviours as the standard management expected from them and they acted accordingly.

#### Safe and unsafe corporate cultures

2.3.7 Culture, like personality, involves deep-seated traits and it is extremely resistant to change. As with

personality traits, change can be accomplished, but slowly and over prolonged periods of time. By identifying what constitutes a good safety-oriented corporate culture and its characteristics, managers can change and improve existing corporate culture by setting examples which are consistent across the whole value system. A safety culture within an organization can be regarded as a set of beliefs, norms, attitudes, roles and social and technical practices concerned with minimizing exposure of employees, managers, customers and members of the general public to conditions considered dangerous or hazardous.<sup>25</sup> It is one which promotes among participants a shared attitude of concern for the consequences of their actions, an attitude which would cover material consequences as well as the possible effects on **people**.<sup>26</sup>

2.3.8 In general terms, the characteristics which define a safe culture and which decision-makers should observe when modelling corporate safety culture include the following:

- senior management places strong emphasis on safety as part of the strategy of controlling risks;
- decision-makers and operational personnel hold a realistic view of the short- and long-term hazards involved in the organization's activities;
- those in top positions do not use their influence to force their views or to avoid criticism about safety issues;
- those in top positions implement measures to contain the consequences of identified safety deficiencies;
- those in top positions foster a climate in which there is a positive attitude towards criticisms, comments and feedback from lower levels of the organization;
- there is an awareness of the importance of communicating relevant safety information at all levels of the organization (**both within it and with outside entities**);
- there is promotion of appropriate, realistic and workable rules relating to hazards, to safety and to potential sources of damage, with such rules being supported and endorsed throughout the organization; and
- personnel are well trained and well educated and fully understand the consequences of unsafe acts.

2.3.9 On 19 October 1984, a Piper PA-31 Navajo on a night IFR flight from Edmonton to Peace River crashed into high terrain 20 miles southeast of High Prairie, Alberta, Canada. Six passengers perished; the pilot and three other passengers survived. The investigation determined that the pilot descended in cloud to below the minimum obstacle clearance altitude, a violation which eventually triggered the accident. However, a major objective of the Canadian Aviation Safety Board was "... to discover the circumstances which influenced the pilot to deviate from accepted safe operating practices ... *Although the final decision in an aircraft cockpit rests with the captain, that decision is often influenced by factors over which he has no direct control ...*" (italics added).

2.3.10 The Board then decided to investigate the company work environment. In so doing, it found out that:

"In early 1984, a lack of adequate communication between pilots and management was noted by the Air Carrier Branch of Transport Canada. The company chief pilot was subsequently appraised of the problem ..."

"Crews ... were expected to carry out the operation without further supervision and to adhere as closely as possible to the published schedule ... some pilots worked a six-week day and were expected at times to carry pagers during their day off ..."

"Some pilots reported that they sensed a subtle but significant pressure to undertake and complete flights ... the chief pilot set an example of non-compliance with prescribed weather limitations ..."

"Pilots ... were encouraged by company management to file VFR, even when the weather might be marginal ... VFR flights took less time, fuel and facilitated arrivals ... pilots admitted cancelling IFR flight plans while still in IMC ... they often descended below prescribed weather minima in an attempt to land ..."

"... personnel were apprehensive about doing anything which management would consider as not in the best interests of the company. Confrontation between pilots and management were reported as frequent and often led to the resignation of the employee to avoid imminent dismissal ... Company management did not consider the exchanges were of a confrontational nature ..."

The Report concludes:

"The descent procedure used by the pilot was similar to that used during his initial route check into High

Prairie six weeks earlier with a senior company pilot. While the pilot knew that this action was contrary to regulations, *he believed it was safe.*" (italics added).

This shortcut:

"... would have allowed the pilot to regain his schedule. By completing the assigned schedule, he expected to avoid further discord with management, thus prolonging his employment with the company."<sup>27</sup>

2.3.11 These excerpts from the relevant section of the official report can be easily seen to contrast with the characteristics of safe corporate culture listed in 2.3.8. They also provide guidance regarding areas of remedial action decision-makers can act upon to influence and change corporate culture.

### The structure of organizations

2.3.12 The *design of the organization*, i.e. its permanent structures and hierarchies, relates to organizational performance similar to the way body constitution relates to human performance. The role of the organization and its structure is to facilitate departmental interfaces, connecting and joining departments together.<sup>28</sup> On 18 November 1987, discarded smoker's material probably set fire to highly inflammable rubbish that had been allowed to accumulate in the running tracks of an escalator at the King's Cross underground station in London, England. Eventually a flash-over occurred and 31 people were killed and many others seriously injured. The Report of the Investigation into the King's Cross underground fire identified that:

"... running tracks were not regularly cleaned, partly due to organizational changes which blurred maintenance and cleaning responsibilities ... Safety specialists scattered over three directorates focused on occupational and operational safety, but passenger safety was neglected ... Inadequate fire and emergency training were given to staff ... No evacuation plans existed for King's Cross underground station ... Trains do not have a public address system and there were no public telephones at King's Cross station."<sup>29</sup>

2.3.13 In fact, practices in defining and building the structure of organizations had come under the scrutiny of the research community well before this accident. There were compelling reasons for this research. Investigation of well-publicized, major catastrophes in sociotechnical systems clearly suggested that it is quite possible to correctly design individual components of the organizational structure (departments, sections, etc.) so that they can achieve their assigned objectives safely and efficiently,

and yet fail to secure over-all organizational safety and effectiveness because of inattention to the way those individual components interact when integrated. If the structure is randomly designed, organizations may collapse when operating under pressure (very much in the same way that incorrectly designed displays or controls will induce human error and provoke safety breakdowns when under operational pressures).

2.3.14 There are several components decision-makers should consider when defining the structure of organizations:

- **Complexity.** This includes the required number of managerial levels, the required division of labour and job specialization (departments and sections), the degree to which operational personnel and facilities must be geographically dispersed or centralized and the extent to which mechanisms which facilitate communication between levels have been designed into the organization.
- **Standardization**, which is related to the complexity of the job and the level of professionalism of employees. In general terms, the simpler the job (e.g. assembly-line manufacturing), the greater the benefits of standardization; the more complex the job (e.g. management tasks requiring high levels of professionalism), the lower the level of standardization desirable. Aviation operational activities are, nevertheless, highly proceduralized, even when the highest levels of professionalism are involved. Complex tasks, such as flight deck management, require *both* high levels of professionalism and standardization.
- **Centralization** of the formal decision-making process. This depends on the stability and predictability of the surrounding environment: unpredictable environments require low centralization to rapidly cope with unexpected changes and vice versa.
- **Adaptability to the environment**<sup>30</sup>. This is the key to success and ultimately to the survival of organizations. Environmental uncertainty is the most powerful of all the system factors affecting organizational design. In highly uncertain environments, organizations should be flexible and capable of rapid response to change. In highly stable environments, it is desirable to design stability and control for maximum effectiveness.<sup>31</sup>

2.3.15 All these organizational components bear an impact on human performance, which in turn affects the



way organizations achieve their objectives, including safety. The relevance of the organizational structure to the safety deficiencies observed in the King's Cross underground fire is apparent. Organizations with unnecessarily complex structures (too many managerial levels or excessive departmentalization) foster dilution of responsibilities and lack of accountability. They also tend to make interdepartmental communications more difficult. Sluggish interdepartmental communications, especially regarding safety relevant information, reduce safety margins and invite safety breakdowns, as the following accident report further illustrates.

**2.3.16** On 17 February 1991, a DC-9 series 10 cargo aeroplane crashed while taking off from Cleveland-Hopkins International Airport, Ohio, USA. Both pilots were fatally injured and the aircraft was destroyed. The crew had failed to detect and remove ice contamination from the wings. During the investigation, the NTSB determined that several organizations within the aviation system had been aware for years of the propensity of this particular series of aircraft for loss of control caused by a minute amount of wing contamination. The manufacturer had issued numerous articles on the subject, and three previous accidents on similar types had been attributed to the same cause. However, the report indicates that, because of the absence of a communications structure:

"... there was no system to ensure that the critical information reaches all line pilots of these airplanes ... the most critical cue that was not provided to the crew on the night of the accident was information that was apparently readily available and known throughout much of the aviation community, that being the sensitivity and vulnerability of the DC-9 series 10 aircraft to minute amounts of ice contamination on the upper surfaces of the plane's wings."

The report concludes:

"The National Transportation Safety Board determines that the probable cause of this accident was the failure of the flight crew to detect and remove ice contamination on the airplane's wings, which was largely a result of a lack of appropriate response by the Federal Aviation Administration, Douglas Aircraft Company and Ryan International Airlines to the known critical effect that a minute amount of contamination has on the stall characteristics of the DC-9 series 10 airplane ..."

### Regulatory compliance

**2.3.17** When internal responsibilities regarding safety are not clearly defined, organizations tend to rely

excessively on external sources to discharge them, i.e. regulatory authorities. Regulations serve a purpose in that certain safety procedures or equipment would never be adopted without them. However, regulations usually represent *minimum* levels of safety compliance; furthermore, if regulations are formally applied but the sense of them is lost, the original reason for introducing them is quickly forgotten. It follows that legislation is, at best, a limited way of affecting human behaviour. Regulations cannot cover all risks involved in aviation since each accident is unique; hence the importance of risk management programmes such as those discussed in 2.5.5. Organizations leaning heavily on regulations to pursue safety usually do not include a risk management structure. The danger of excessive reliance on regulations in lieu of properly organized risk management structures is best illustrated by the opening statement in the findings of most accident reports: "... the airplane was certificated, equipped and maintained in accordance with existing regulations and approved procedures ... the crew were certificated, qualified and experienced for their duties ..." Yet the accident occurred.

**2.3.18** On Monday, 14 November 1988, an Embraer 110 Bandeirante aircraft on a scheduled passenger flight crashed in the vicinity of the Ilmajoki Airport in Finland. The Finnish Board of Inquiry came to the conclusion that the immediate cause of the accident was the [flight crew] decision to continue the NDB approach below the minimum descent altitude, without the required visual contact. The Board also found as a contributing factor the performance pressures that originated from the airline's poor safety culture. In pursuing the organizational issues which might have contributed to the accident, the investigation revealed:

"... serious deficiencies in the operation of the airline as well as in the activities of the airport operator and the authorities. Also the legislation was found to be out of date and insufficient, especially as far as commercial flight operations are concerned."

The report is an outstanding example of systemic approaches to accident investigation and as such, it is extremely rich in prevention lessons. The discussion about regulatory compliance is particularly applicable to this section. The report first discusses the very important contribution of regulatory compliance to safety in the following terms:

"... Flight safety is also affected by the effectiveness of the supervision carried out by the authorities and by what measures are undertaken in response to what is uncovered in the supervision. If the authorities cannot or will not intervene when safety regulations have

been violated or if these violations are not even noticed due to ineffective supervision, the violations will probably begin to be regarded as a minor matter ...”

Having established the importance of regulatory compliance, the report then goes on to consider an important shortcoming in regulations — formal compliance — as follows:

“... If the authorities are unable to assess the substantive conditions for operating an airline, or they do not have sufficient authority to do so, the supervision and the resulting measures must be carried out purely on formal grounds. Instead of broad assessment, this merely leads to the judging of violations committed by individuals, and it is not possible to come to grips with fundamental factors in the organization and operative environment that endanger safety ...”

The report’s conclusion on the scope and reach of regulatory compliance as a tool in pursuing safety, as it applies not only to the accident under investigation but to the aviation system as a whole, leaves no room for misunderstanding:

“... in the course of the investigation, no particular reason arose to question in general the sufficient competence of the pilots or other operational personnel. What is primarily at issue is the company’s poor safety culture ... Because of this, measures that are directed by the National Board of Aviation at the licenses and ratings of individual pilots would scarcely affect the safety of the company’s flight operations unless, at the same time, one can ensure that the company management adopts the proper attitude and has sufficient qualifications for carrying out its functions.”<sup>33</sup>

## 2.4 ALLOCATION OF RESOURCES

2.4.1 Organizations in sociotechnical systems have to allocate resources to two distinct objectives: production and safety. In the long term, these are clearly compatible goals; but given that resources are finite, there are likely to be many occasions when there will be short-term conflicts of interest. Resources allocated to the pursuit of production (Figure 2-1) could diminish those available to safety and vice versa<sup>34</sup>. When facing this dilemma, organizations with inadequate structures may emphasize production management over safety or risk management. Although a perfectly understandable reaction, it is ill-advised and contributes to additional safety deficiencies. The King’s Cross underground fire investigation report states:

“... The Chairman of London Regional Transport ... told me that whereas financial matters were strictly monitored, safety was not ... smoke detectors were not installed since the expense was not [felt to be] justified; water fog equipment had been installed in 1948 and could not be used because of rust problems ... In my view, he was mistaken as to his responsibility.”

The dilemma of allocation of resources may be further complicated by local perceptions of what constitutes a risk and by cultural considerations regarding the value safety has in the eyes of a society. It has been advanced that the number of accidents occurring in one country largely reflects the accident rate its population is ready to tolerate; in terms of safety, investment is made only as is necessary to maintain this rate. The tolerance rate and the ensuing allocation of resources to pursue safety vary considerably across the community.

### Accidents in complex technological systems

2.4.2 In concluding this comparison between human beings and organizations, we will now consider the brain, or *management*. In order to understand how decision-makers’ actions or inactions influence safety, it is necessary to introduce a contemporary view on accident causation.<sup>35</sup> As a complex sociotechnical system, aviation requires the precise co-ordination of a large number of human and mechanical elements for its functioning. It also possesses elaborate safety defences. Accidents in such a system are the product of the conjunction of a number of enabling factors, each one necessary but in itself not sufficient to breach system defences. Because of constant technological progress, major equipment failures or operational personnel errors are seldom the root cause of breakdowns in system safety defences. Instead, these breakdowns are the consequence of human *decision-making* failures which occur primarily within managerial sectors.

2.4.3 Depending upon the immediacy of their consequences, failures can be viewed as *active failures*, which are errors and violations having an immediate adverse effect, generally associated with the operational personnel (pilot, controller, mechanic, etc.); or *latent failures*, which are decisions or actions, the consequences of which may remain dormant for a long time. Latent failures become evident when triggered by active failures, technical problems or adverse system conditions, breaking through system defences. Latent failures are present in the system well before an accident and are most likely bred by decision-makers, regulators and other people far removed

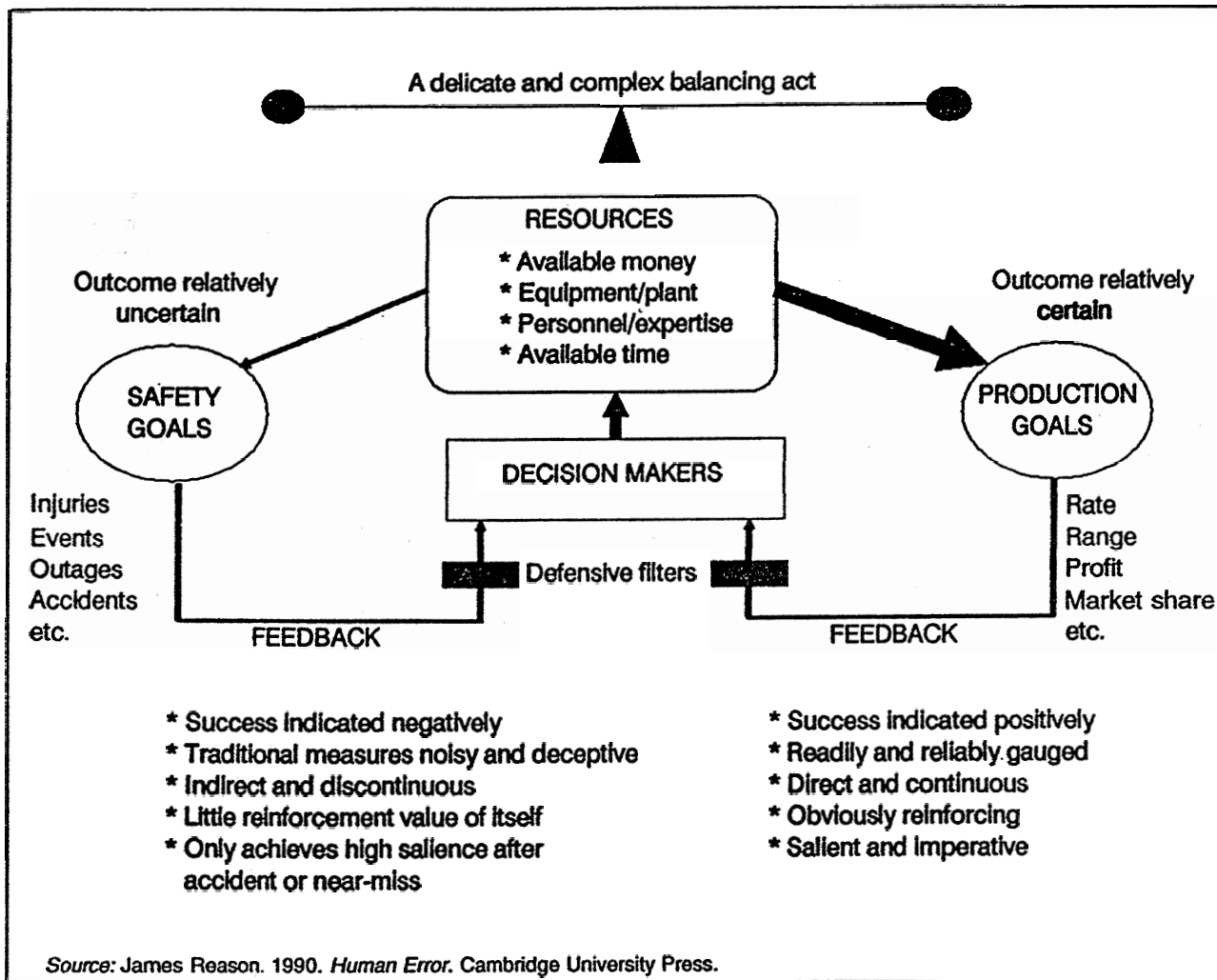

**Figure 2-1. A summary of some of the factors that contribute to fallible, high-level decision-making**

in time and space from the event. Those at the human-machine interface, the operational personnel, are the inheritors of defects in the system, such as those created by poor design, conflicting goals, defective organizations and bad management decisions. They simply create the conditions under which the latent failures can reveal themselves. Safety efforts should be directed at discovering and solving these latent failures rather than by localized efforts to minimize active failures. Active failures are only the proverbial tip of the iceberg.

2.4.4 The human contributions to accidents are illustrated in Figures 2-2 and 2-3. Most latent failures have

their primary origin in errors made by the decision-makers. Even in the best run organizations, a number of important decisions will have a downside by virtue of being made by humans who are subject to human biases and limitations as well as to contextual constraints. Since some of these unsafe decisions cannot be prevented, steps must be taken to detect them and to reduce their adverse consequences. Fallible decisions in line management may take the form of inadequate procedures; poor scheduling or neglect of recognizable hazards. They may lead to inadequate skills, inappropriate rules or poor knowledge or they may be revealed by poor planning or workmanship. Fallible decisions may also be caused by a lack of resources.

2.4.5 The response of management to safety information is vital, since safety cannot be enhanced unless corrective action is timely and effective. This response may vary from *denial actions*, by which "offenders" are dismissed or the validity of their observations challenged; to *repair actions*, in which "offenders" are disciplined or relocated and dangerous items of equipment modified to prevent specific recurrence of an observed failure; to *reform actions*, in which the problem is acknowledged and global action taken, leading to an *in-depth reappraisal* and eventual reform of the system as a whole.<sup>36</sup> These actions relate to the three-level response discussed in 1.10.

2.4.6 On 26 September 1989, a Fairchild Metro III on a scheduled flight from Vancouver to Terrace, British Columbia, Canada, with two pilots and five passengers on board crashed one quarter mile to the west of the destina-

tion airport while the crew was attempting to carry out a missed approach procedure in IMC. The aircraft was destroyed by the impact and a post-crash fire. All seven occupants were fatally injured in the crash.<sup>37</sup> Analysis of the performance of the flight crew suggested lapses in the application of technical and psychomotor skills. It also identified breakdowns in flight deck activities and co-ordination of tasks. These are the active failures which, combined with adverse weather conditions, triggered the accident. The investigating authority, however, decided to broaden the scope of the investigation, thus unveiling some of the latent failures which set the stage for this accident:

- Despite its history, the company had been granted a waiver to operate large passenger aircraft under a less stringent operating standard. The regulatory

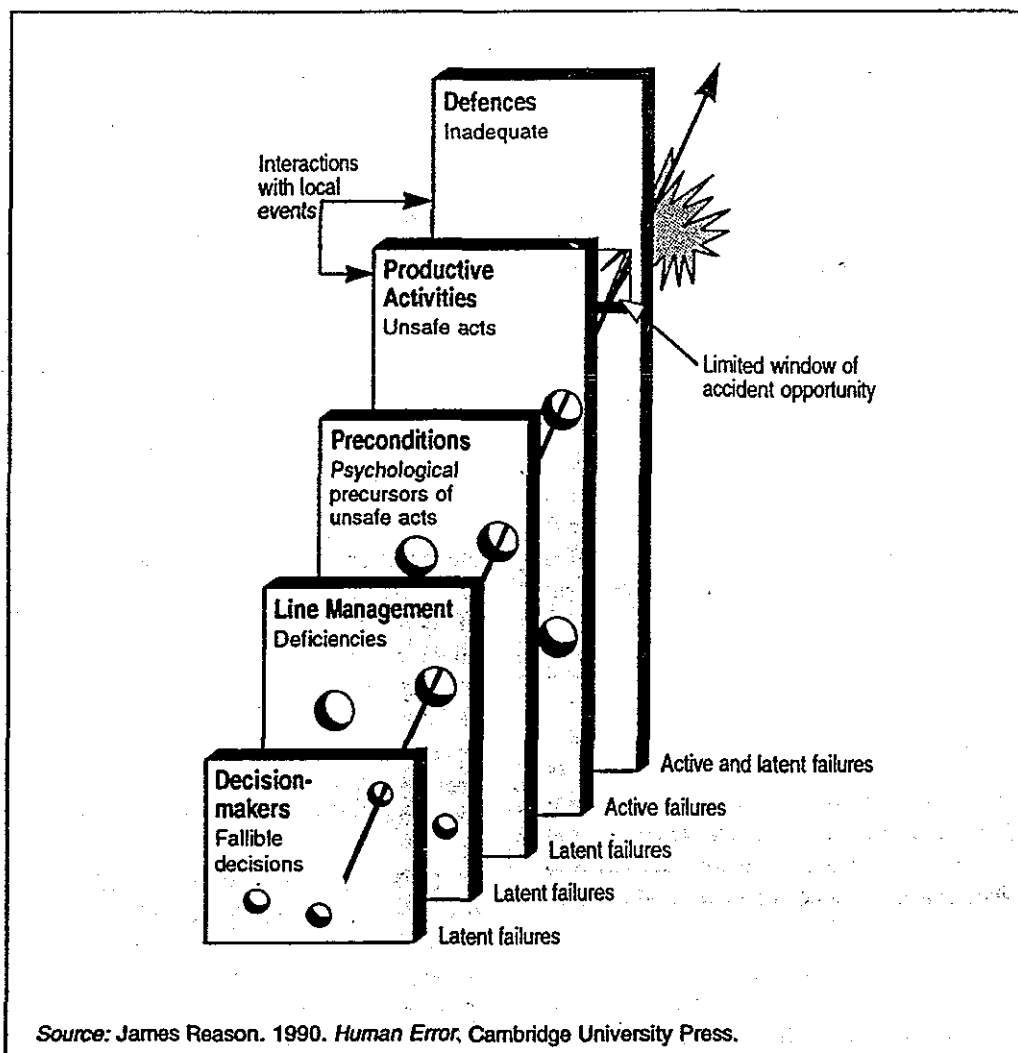

Figure 2-2. Human contribution to accidents in complex systems

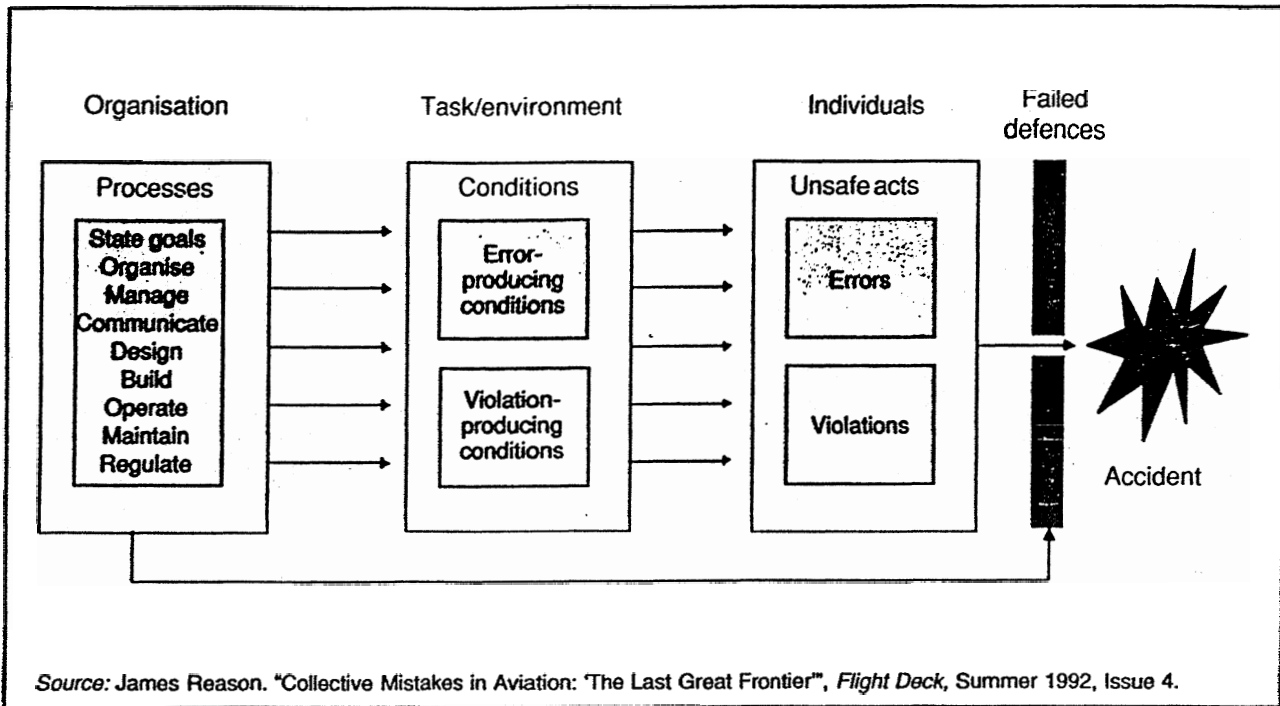

Figure 2-3. The basic elements of an organizational accident

authority had authorized the company and its pilots, through the mechanism of a waiver, to apply the standards of less stringent operating requirements (i.e. applicable to small aircraft under 12 500 pounds gross weight) rather than the more restrictive standards applicable to large aircraft above 12 500 pounds gross weight. This implied reduced training requirements and less frequent proficiency checking.

- The company involved had a questionable record with regard to regulatory compliance. In the two years previous to the accident, government regulators had issued three suspensions or cancellations of the company's operating certificate. The certificate had been reinstated without on-site inspection by the regulatory authority to ensure that corrective actions had been adopted by the company.
- The company did not employ standardized procedures. Interviews with company pilots indicated that there was often confusion among pilots about what operational directives were in place.

- The regulatory authority definitions and descriptions detailing the visual references required to carry out a circling approach were ambiguous and open to misinterpretation.

**2.4.7** Discussing the accident with commendable introspection, the regulatory authority correctly identifies the reform actions required by concluding in its periodic safety newsletter: "... in the context of system safety, one might argue that organizational deficiencies related to training, standards and risk management led two relatively unseasoned pilots, typical products of the flight training system in this country, to commit a variety of transgressions that, clearly, were within the means of their company and the government to prevent."<sup>38</sup>

**2.4.8** On the night of 2 December 1984, a gas leak from a pesticide plant devastated the Indian city of Bhopal in the worst industrial disaster on record. More than 2 500 people were killed, and more than 200 000 were injured. The immediate cause of the leak was an influx of water into a methyl isocyanate (MIC) storage tank. The leak was the result of "botched maintenance, operator error, improvised bypass pipes, failed safety systems,

incompetent management, drought, agricultural economics and bad government decisions".<sup>39</sup> The analysis of the Bhopal disaster is a regrettable textbook example of the concepts advanced by this chapter:

"Bhopal's plant rigid organizational structure ... was one of the three primary causes of the accident ... the Bhopal plant was plagued by labour relations and internal management disputes ... for a period of fifteen years prior to the accident, the plant had been run by eight different managers ... many of them came from different backgrounds, with little or no relevant experience."

"The discontinuity of the plant management, its authoritative and sometimes manipulative managerial style and the non-adaptive and unresponsive organizational system, collectively contributed to the accident. The latter element, i.e., organizational rigidity, was primarily responsible for not responding and taking the necessary and corrective course of actions to deal with the five reported major accidents occurring at the plant between 1981 and 1984 ... crisis often occur because warning signals were not attended to ..."

"The Bhopal plant's organizational culture should also be held responsible for not heeding many operational warnings regarding safety problems ... Bhopal's monolithic organizational culture, as the plant's operational milieu, only fostered the centralization of decision-making by rules and regulations or by standardization and hierarchy, both of which required high control and surveillance ..."

"Many key personnel were being released for independent operation without having gained sufficient understanding of safe operating procedures ..."<sup>40</sup>

### The traits of a safe organization

2.4.9 What are, then, the traits of a safe organization? In general terms, safe organizations:

- pursue safety as one of the objectives of the organization and regard safety as a major contributor in achieving production goals;
- have developed appropriate risk management structures, which allow for an appropriate balance between production management and risk management;
- enjoy an open, good and healthy safety corporate culture;

- possess a structure which has been designed with a suitable degree of complexity, standardized procedures and centralized decision-making which is consistent with the objectives of the organization and the characteristics of the surrounding environment;
- rely on internal responsibility rather than regulatory compliance to achieve safety objectives; and
- respond to observed safety deficiencies with long-term measures in response to latent failures as well as short-term, localized actions in response to active failures.

## 2.5 MANAGEMENT'S CONTRIBUTION TO SAFETY

2.5.1 In 1986, a major aircraft manufacturer completed a world-wide airline operators survey with a view to helping control what was dubbed "crew-caused accidents". The ensuing report became widely publicized and a milestone within the airline training community since it provided valuable information applicable to flight crew training.<sup>41</sup> Although, by its nature, the survey focused narrowly on flight crews, the researchers were confronted with evidence which suggested that there was more than just crew error to safe airline operations.

2.5.2 The report indicates that one characteristic of the airlines identified as safer was *management emphasis on safety*. These airlines:

"... characterize safety as beginning at the top of the organization with a strong emphasis on safety and this permeates the entire operation. Flight operations and training managers recognize their responsibility to flight safety and are dedicated to creating and enforcing safety-oriented policies ... There is a method of getting information to the flight crews expeditiously and a policy that encourages confidential feedback from pilots to management ... This management attitude, while somewhat difficult to describe, is a dynamic force that sets the stage for standardization and discipline in the cockpit brought about and reinforced by a training programme oriented to safety issues."

2.5.3 Three years later, in an address given before the Aero Club of Washington, D.C., on 28 March 1989, an internationally recognized advocate of safety through management asserted:

"Management attitudes can be translated into concrete action in many ways. Most obvious are the fundamentals: the provision of well-equipped, well-maintained, standardized cockpits; the careful development and implementation of, and rigid adherence to, standardized operating procedures; and a thorough training and checking program that ensures that the individual pilots have the requisite skills to operate the aircraft safely. These actions build the foundations upon which everything else rests."<sup>42</sup>

The crash of a De Havilland DHC-6-300 Twin Otter on 28 October 1989 into high terrain, near Halawa Bay, Molokai, Hawaii, while attempting to continue a VFR flight into deteriorating VMC provides an instructive example of "management failure". The aircraft accident report includes the following conclusion:

"In summary, the Safety Board concludes that [the company's] management provided inadequate supervision of its personnel, training and flight operations. The numerous deficiencies evident during the investigation relative to the IFR training of the pilots, the reduced ground school training, the lack of CRM training, the captain's known behavioural traits, and the policy of not using the weather radar systems installed on the airplanes, were the responsibility of the airline's management to correct. The failure of the management personnel to correct these deficiencies contributed to the events that led to this accident."<sup>43</sup>

2.5.4 The quotations in the previous paragraphs set the underlying rationale for this section and demonstrate the critical contribution of management to sociotechnical systems safety, which is the objective of this chapter. Before addressing *what* management can do, however, it is pertinent to discuss *why* management should act on safety.

#### Why management should take an active stance on safety

2.5.5 Aside from the moral considerations regarding potential injury or loss of human life and preservation of property, management should act because of the economics of aviation safety. Section 2 discusses the dilemma of dividing finite resources between production and safety goals. Although seemingly incompatible in the short-term, these goals are perfectly compatible when considered from a long-term perspective. It is a recognized generalization that the safest organizations are often the most efficient. There are inevitable trade-offs between safety and finance. However, safe organizations do not allow these trade-offs or apparent incompatibilities to

reduce the safety standards below a *minimum standard* which is defined beforehand and thus becomes one of the objectives of the organization.<sup>44</sup>

2.5.6 When contemplating trade-offs between safety and production, management should evaluate the financial consequences of the decision. Since this trade-off involves risk, management must consider the cost involved in accepting such risk, i.e. *how much will it cost the organization to have an accident*. While there are insured costs (those covered by paying premiums to insurance companies) which can be recovered, there are also uninsured costs which cannot, and they may be generally double or triple the insured costs. Typical uninsured costs of an accident include:

- insurance deductibles
- lost time and overtime
- cost of the investigation
- cost of hiring and training replacements
- loss of productivity of injured personnel
- cost of restoration of order
- loss of use of equipment
- cost of rental or lease of replacement equipment
- increased operating costs on remaining equipment
- loss of spares or specialized equipment
- fines and citations
- legal fees resulting from the accident
- increased insurance premiums
- liability claims in excess of insurance
- loss of business and damage to reputation
- cost of corrective action

2.5.7 Those in the best position to effect accident prevention by eliminating unacceptable risks are those who can introduce changes in the organization, its structure, corporate culture, policies and procedures, etc. No one is in a better position to produce these changes than management. Therefore, the economics of aviation safety and the ability to produce systemic and effective change underlie the justification for management to act on safety.<sup>45</sup>

#### What management can do to take an active stance on safety

2.5.8 In a document such as this manual which is directed to such a wide audience in different States, in different sizes of organizations and, most importantly, in different structures of organizations, it is impossible to be prescriptive about management actions in relation to safety. There are, nonetheless, a few general principles which apply anywhere; these are discussed in the balance of this section.

**2.5.9 Allocation of resources.** From the simplest of perspectives, management's most obvious contribution to safety is in the allocation of adequate and necessary resources to safely achieve the production goals of the organization. The issues underlying this allocation are discussed in 2.3.18 as well as in the opening paragraphs of this section. In practical terms, the first quotation in 3.3 can be viewed as a listing of the "most wanted" items management should pursue when deciding on the allocation of resources.

**2.5.10 Safety programmes and safety feedback systems.** There are other activities involving allocation of resources which are not as obvious but are nevertheless equally important. These activities are discussed in-depth in the *Accident Prevention Manual (Doc 9422)* and are mentioned briefly in this section. The most important is the implementation, continued operation and visible support of a company safety programme. Such programmes should include not only flight operations safety, but also maintenance safety, ramp safety, etc. The programme should be administered by an independent company safety officer who reports directly to the highest level of corporate management. Company safety officers and their staff must be quality control managers, looking for corporate safety deficiencies rather than pointing fingers at individual errors. To discharge their responsibilities, safety officers need information which may come from several sources: internal safety audits which identify potential safety hazards, internal incident reporting systems, internal investigation of critical incidents as well as performance monitoring programmes — both for the company and the industry. The possible feedback loops of an internal audit system and their relative values in terms of prevention are discussed in 2.5.14. An often-overlooked source of information is the participation in industry-wide safety fora, such as conferences and workshops organized by international associations. Armed with the information thus obtained, the safety officer may then implement a programme of disseminating critical safety information to all personnel. The stage for setting a safety-oriented organizational climate is thus set.

**2.5.11 Standard operating procedures.** There is an even more subtle activity that management can undertake to contribute to safety. The development of, implementation of and adherence to standardized operating procedures (SOPs) have recently been recognized as a major contribution by management to safety. Failure to conform to sound SOPs has indeed been linked to numerous accidents and incidents. There are Human Factors considerations related to SOPs which concern both the underlying philosophy and the design of such procedures. *Procedures* are specifications for conducting predetermined actions; they specify a progression of

actions to assist operational personnel in achieving their tasks in a manner which is logical, efficient and, most importantly, error-resistant. Procedures are not produced in a vacuum nor are they inherent in the equipment; they are based on a broad concept of operation. There is a link between procedures and philosophy, which Wiener and Degani have called "The four Ps of operations": Philosophy, Policies, Procedures and Practices.<sup>46</sup>

**2.5.12** These researchers contend that, by establishing a *philosophy* of operations, management states how it wants the organization to function. Such philosophy can only be established by the highest corporate level. From philosophy, *policies* can be developed. Policies are broad specifications of the manner in which management expects tasks to be accomplished — training, flying, maintenance, exercise of authority, personal conduct, etc. Policies are usually dictated by line management. The *procedures*, normally developed by supervisors, determine how tasks will be accomplished. The procedures must be designed to be consistent with the policies, which must be consistent with the over-all guiding philosophy. Lastly, management must effect the quality control to make sure that *practices* in the operational environment do not deviate from written procedures. Any attempt to shortcut this process may well produce inconsistent procedures, which will breed doubts among the operational personnel about the preferred behaviour management expects from them to accomplish their task (Figure 2-4).

**2.5.13** Philosophies, policies and procedures must be developed with due consideration for the operational environment in which they will be used. Incompatibility of the procedures with the operational environment can lead to the informal adoption of unsafe operating practices. External activities, type of operation and the layout of the cockpit or workstation are factors to be considered when evaluating the operational environment in which SOPs will be used. Feedback from operational situations, through the observed practices of or reports from operational personnel, is essential to guarantee that the bridge between the Ps and the operational environment remains intact.

**2.5.14** The example of the Ground Proximity Warning System (GPWS) Policy, as instituted by one operator<sup>47</sup>, illustrates this point:

- **Philosophy:** it is a corporate goal to be a safe and secure airline, as stated in the corporate mission and goals.
- **Policy:** in the event of a full, or partial, "Pull-up" or other hard (red) warning, the following action must be taken promptly:



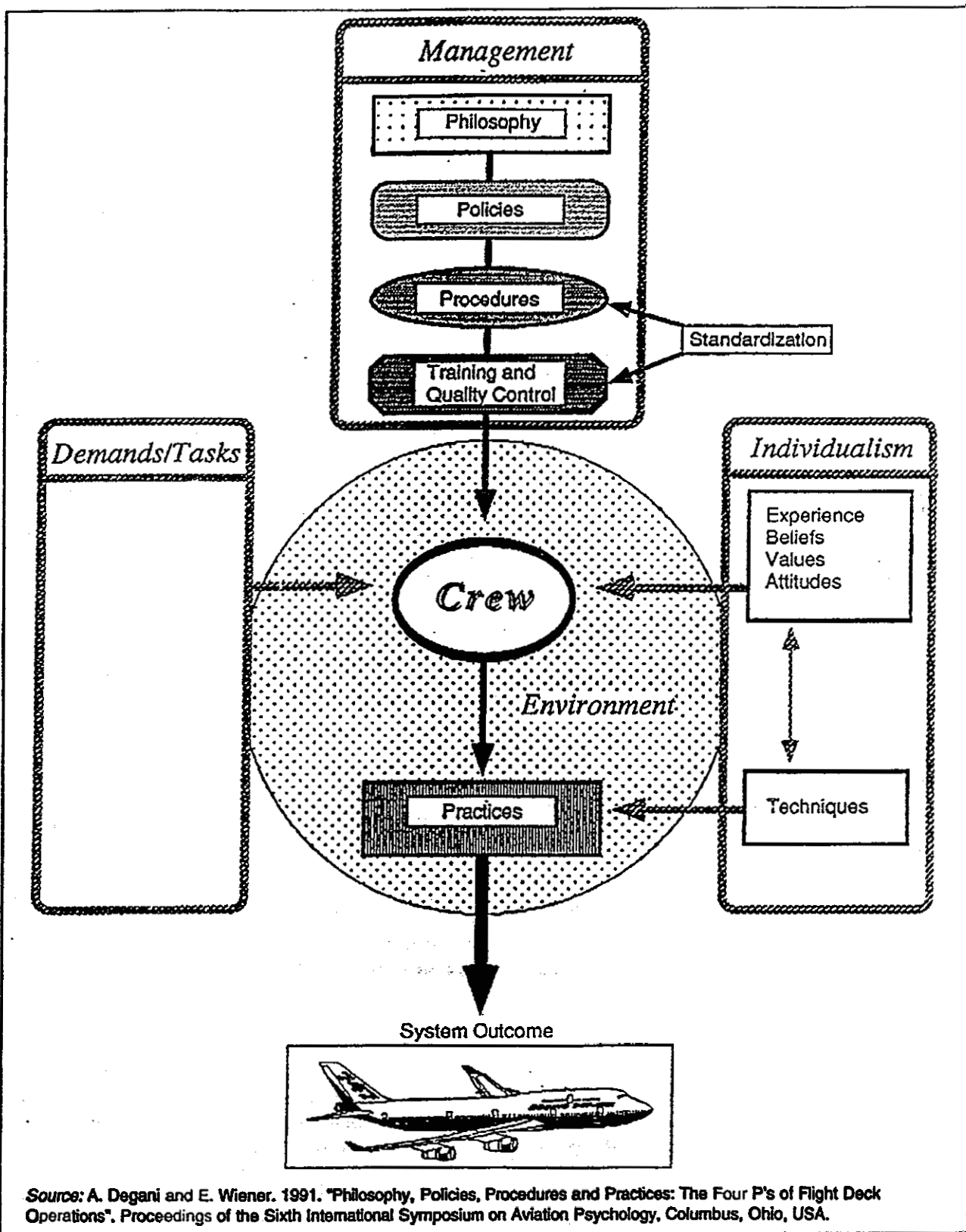

Source: A. Degani and E. Wiener. 1991. "Philosophy, Policies, Procedures and Practices: The Four P's of Flight Deck Operations". Proceedings of the Sixth International Symposium on Aviation Psychology, Columbus, Ohio, USA.

Figure 2-4. The four Ps

## a) Below MSA (Minimum Safe Altitude)

Announce "PULL-UP Go-Around"

Immediately complete the pull-up manoeuvre in all circumstances.

## b) At and Above MSA

Immediately assess aircraft position, altitude and vertical speed. If proximity to MSA is in doubt, take action as in a) above.

- *Procedure:* GPWS pull-up manoeuvre is described in fleet-specific manuals. Describe the call-outs by the handling pilot and the non-handling pilot — procedures at and below MSA and procedures above MSA; define MSA during climb and descent in case of ambiguities and include additional operational information deemed appropriate for the crews to observe the GPWS Policy.
- *Practices:* do flight crews observe the policy and follow the procedure in operational conditions?

2.5.15 In the GPWS example discussed above, the operator's original policy mandated an immediate pull-up upon receipt of any GPWS warning, regardless of altitude and position of the aircraft. Operational feedback obtained through the operator's internal safety information system, however, indicated that during the first calendar year after this policy was implemented, GPWS alerts had not been followed by a pull-up in 60% of occasions. This was due to a variety of reasons, including false and nuisance warnings. Of particular concern was the fact that pull-ups had not been initiated on 20% of occasions *when the warning had been genuine*. An obvious discrepancy between the three first Ps and the last one — Practices — was evident. The safety services of the operator determined that the reason for this discrepancy between philosophy, policy, procedures and practice centred around the unreliability of the technology which resulted in false and nuisance warnings. In some cases, warnings had been triggered at 37 000 ft flying in cruise, immediately after take-off, when there were no obstacles in the flight path or in holding patterns, with other aircraft 1 000 ft below the host GPWS. This feedback data and its analysis led the operator to review its GPWS policy and amend it to that included in 2.5.14, with the immediate intent of ensuring compliance with the policy on all occasions.

2.5.16 *Internal feedback and trend-monitoring systems.* The previous paragraph illustrates the importance of the feedback from the "front end", that is, from day-to-day operations, so that management can effect the control of the operations that policies and procedures support.

Figure 2-5 depicts three possible feedback loops.<sup>48</sup> *Loop 1* feeds back a company's accident statistics. In most cases, the information supplied is too late for control, because the events that safety management seeks to eliminate have already occurred. *Loop 2* carries information about unsafe acts observed in daily operations. However, unsafe acts represent only the tip of the iceberg since many actions that cause accidents cannot be recognized as such in advance. This information is usually disseminated at the lower levels of the organization, i.e. operational personnel and supervisors. *Loop 3* provides the greatest opportunity for proactive control of safety.

2.5.17 *Risk management.* The feedback loops, and loop 3 in particular, allow managers to assess the level of risks involved in the operations and to determine logical approaches when deciding to act upon them. The concept of risk management is discussed in the *Accident Prevention Manual* and is introduced in this chapter in 2.5.10. The basic theory is based on the following assumptions:<sup>49</sup>

- There is always risk. Some risks can be accepted, some — but not all — can be eliminated and some can be reduced to the point where they are acceptable.
- Decisions on risk are managerial decisions; hence the term "risk management".
- Risk management decisions follow a logical pattern.

2.5.18 The first step in the risk management process is to make an accurate assessment of hazards (*hazard assessment*); otherwise, decisions will be made on the basis of inaccurate information. One way to assess hazards is to subjectively evaluate them based on probability of occurrence, severity when they occur and exposure to them. The second step is to make an assessment of the risk involved (*risk assessment*) and determine whether the organization is prepared to accept that risk. Again, the crucial points are the accuracy of the information about the nature of the hazard and the willingness to use this information. The third step involves finding those hazards that can be eliminated (*hazard elimination*) and eliminating them. If none of the identified hazards can be eliminated, then the fourth step is to look for the hazards that can be reduced (*hazard reduction*). The objective is to reduce the exposure to a particular hazard: reduce the probability that it will occur, or reduce its severity when it does occur. In some cases, the risk can be reduced by developing means for safely coping with the hazard.

2.5.19 It must be kept in mind that judging acceptable risk is a subjective, social and legal activity that will

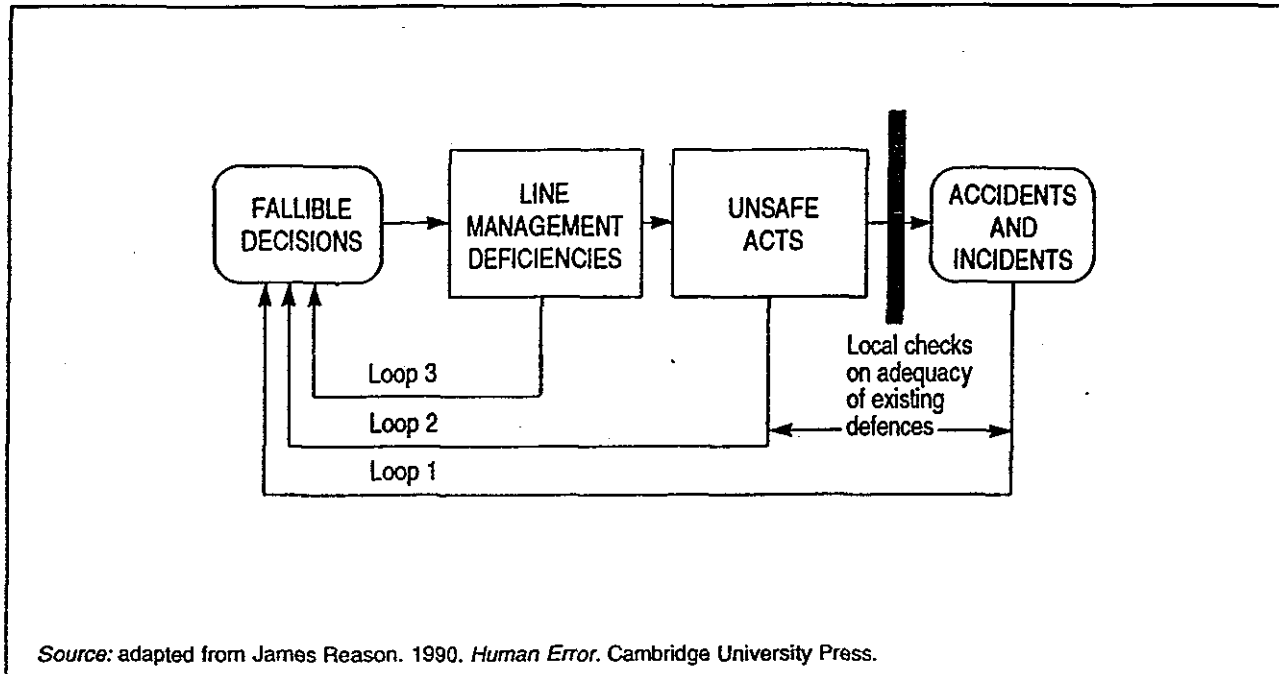

Figure 2-5. Internal feedback and trend-monitoring systems

vary among different cultures and societies and even among organizations within a single culture or society. It follows, according to this line of reasoning, that safety is *judged, not measured*. If, based on an accurate assessment of the hazards, the risks are judged to remain high and unacceptable and, after serious consideration to hazard elimination or reduction, the total risk remains unacceptable, then the obvious decision is to cancel the operation (short term) or to modify the system to bring risks to an acceptable level (longer term). There is room for short-term change around loops 1 and 2, but the long-term changes lie around loop 3 where unsafe organizational structures can be modified and unsafe corporate cultures changed. The importance of this risk management process is that it allows management to clearly see the results of action or inaction. Figure 2-6 illustrates the conventional risk management logic.

2.5.20 In large organizations such as airlines, the costs associated with loss of human life and physical resources dictate that risk management is essential. In order to produce recommendations that do not run counter

to the goals of the organization, a systems approach to risk management must be followed. Such an approach, in which all aspects of the organization's goals and available resources are analysed, offers the best option for ensuring that recommendations concerning risk management are realistic and complementary to the purposes of the organization.<sup>50</sup>

2.5.21 A loop is thus closed. This section presents the opinions of the prevention, research and training communities regarding what management can do to contribute to safety. They complement the background and justification provided by the first two sections in this chapter. There is growing consensus that management must play an active role in achieving aviation system safety. There is also consensus on the need for change and progress, with solid evidence strongly supporting new approaches to the relationship between management, organizations and safety. The case for dealing with management factors and organizational accidents seems to be beyond reasonable challenge.

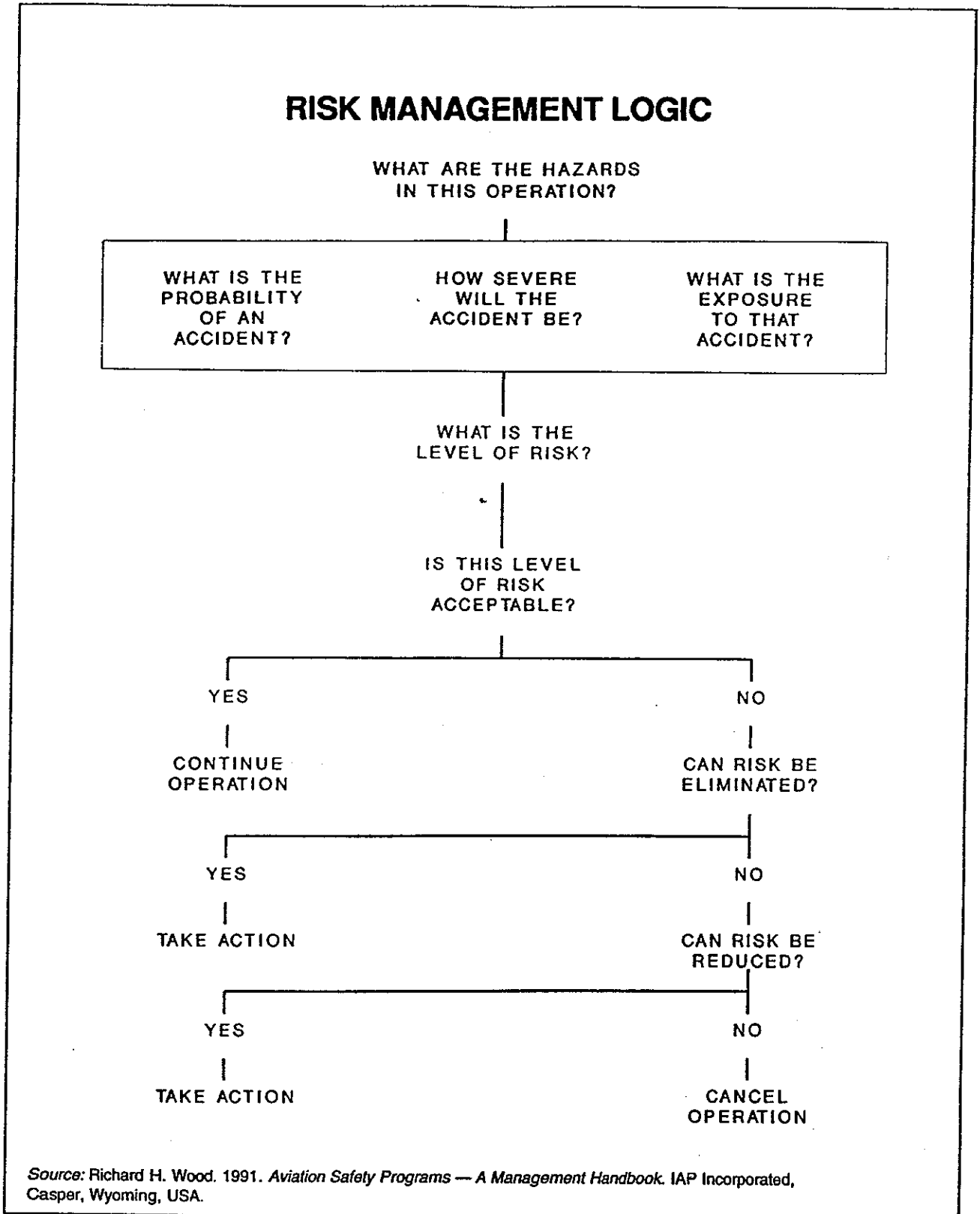

Figure 2-6. Risk management logic

## Chapter 3

# HUMAN FACTORS ISSUES IN THE DEVELOPMENT AND IMPLEMENTATION OF COMMUNICATIONS, NAVIGATION AND SURVEILLANCE/AIR TRAFFIC MANAGEMENT (CNS/ATM) SYSTEMS

### 3.1 INTRODUCTION

#### Historical background

3.1.1 The Tenth Air Navigation Conference (Montreal, 5-20 September 1991) “recognized the importance of Human Factors in the design and transition of future ATC systems”. It also “noted that automation was considered to offer great potential in reducing human error”. It further recommended that “work conducted by ICAO in the field of Human Factors pursuant to ICAO Assembly Resolution A26-9 include, *inter alia*, studies related to the use and transition to future CNS/ATM systems”.

3.1.2 Following the recommendation of the Conference, the ICAO Air Navigation Commission agreed that the plan of action of the Flight Safety and Human Factors Programme would be revised to include work on Human Factors considerations in future aviation systems with an emphasis on CNS/ATM-related human-machine interface aspects.

3.1.3 Based on the decision of the Commission, the Secretariat contacted experts from selected States and international organizations and reviewed recent and ongoing studies to identify Human Factors issues of relevance to ICAO CNS/ATM systems. The survey identified several areas in which application of Human Factors knowledge and experience would enhance future ICAO CNS/ATM systems safety and efficiency:

- **Automation and advanced technology in future ATS systems.** The application of state-of-the-art technology and automation is fundamental to the ICAO CNS/ATM concept. Experience shows that it

is essential to take into account the human element during the design phase so that the resulting system capitalizes upon the relative strengths of humans and computer-based technology. This approach is referred to as a “human-centred” automation.

- **Flight deck/ATS integration.** ICAO CNS/ATM systems will provide for a high level of integration between aircraft and the air traffic control system. This will bring new and different challenges. The various components of the system will interact in new ways, and new means of communication between pilots and air traffic controllers will be available. A dedicated systems approach must be adopted to address the issues associated with this integration (including certification issues) and to ensure that the system as a whole is “user-friendly”.
- **Human performance in future ATS.** The human element is the key to the successful implementation of the ICAO CNS/ATM concept. A broad base of scientific knowledge of human performance in complex systems is available and research continues to provide more. Additional research is still needed regarding the influence of organizational and management factors on individual and team performance in ATS. New techniques such as Team Resource Management (TRM) with Threat and Error Management (TEM) need to be introduced globally. Information transfer in complex systems, the system-wide implications of data-link implementation, automated aids such as conflict prediction and resolution advisory systems, and the allocation of authority and functions between air and ground in advanced systems are areas in which guidance is necessary.

- **Training, selection and licensing of operational personnel.** Acquiring technical skills alone will not guarantee on-the-job performance with high reliability and efficiency. Resource management training programmes specially tailored to ATM have become available under the name Team Resource Management (TRM). Although some successful attempts to address Human Factors training for operational personnel are in place, it is evident that much is lacking and more action in this regard is still desirable. Selection criteria which go beyond consideration of the candidate's technical aptitude and include social and personal characteristics associated with team performance are also important. Licensing requirements which reflect these new training objectives would provide the framework to achieve them.
- **Safety monitoring of ATS activities.** Annex 11 requires that States implement "systematic and appropriate ATS safety management programmes" and that "the acceptable level of safety and safety objectives applicable to the provision of ATS" be established. Existing tools for monitoring safety may not be sufficient in view of the increased complexity and interdependence of the ICAO CNS/ATM activities. Guidance is needed on how ATS activities can be monitored to provide the information required for identifying and resolving safety issues. Emerging tools such as the Line Operations Safety Audit (LOSA) and the Normal Operations Safety Survey (NOSS) should be considered.

#### Development of guidance material

3.1.4 This chapter addresses the Human Factors implications of automation and advanced technology in modern aviation systems, including CNS/ATM systems. It also intends to provide the civil aviation authorities with tools for establishing the requirements for the new systems and for reviewing proposals from manufacturers, from the perspective of Human Factors. This chapter should also be useful for the ICAO panels and study groups working on the ICAO CNS/ATM concept to ensure that Human Factors principles are adequately considered during the development of automation and advanced technology in future systems.

3.1.5 The discussion related to the recommendation of the Tenth Air Navigation Conference notes the potential of automation for reducing human error. There is, however,

a concern among researchers, designers and users, that the indiscriminate application of automation may also create a whole new set of human errors. Experience gained in the operation of complex automated systems in civil aviation and elsewhere indicates that in order to be effective, automation must meet the needs and limitations of users and purchasers (i.e. air traffic services providers and/or civil aviation authorities). This chapter aims at informing designers about the expected role of automation; assisting administrations in the evaluation of the equipment during the procurement process; and explaining to users what to expect from the tools that they will be given to achieve their tasks.

3.1.6 Experience gained with programmes developed outside civil aviation to meet the demands presented by complex systems (most notably in the nuclear power generation and chemical processing and weapons systems industries, all of which have characteristics in common with advanced aviation systems in terms of complexity and integration) is applied throughout the chapter as necessary. These programmes were developed following the failure of projects that produced technically viable systems but which could not be maintained or operated effectively in the field; they ensure that high-technology systems take into account the relevant Human Factors aspects throughout the development cycle, along with the more traditional technical specifications. This is achieved by focusing attention on the operator's performance and reliability as part of the total system performance.

3.1.7 This chapter:

- introduces the historical background of the ICAO CNS/ATM system and discusses the concept;
- presents the role of automation in advanced aviation systems. It also discusses the role of the human operator in such a system. It is *essential* that system designers take the human element into account during the preliminary stages of system design. It also discusses issues and concerns in CNS/ATM system automation;
- introduces the concept of *human-centred* automation, that is automation designed to work with human operators in pursuit of the stated objectives. Human-centred automation does not only enhance safety but also reduces training and operation costs by allowing efficient, effective and safe operation;
- introduces the principles of human-centred automation based on the premise that *a human (pilot,*

*controller, etc.) bears the ultimate responsibility for the safety of flight operation;*

- introduces qualities human-centred automation should possess if it is to remain an effective and valued element of the aviation system. As automation becomes more complex, it will be increasingly difficult for human operators to remain aware of all actions being taken autonomously and thus increasingly difficult to know exactly what the automation is doing and why. Attributes of human-centred automation, capable of preventing such a situation from developing, are also discussed; and
- presents a list of references.

## 3.2 THE ICAO CNS/ATM CONCEPT

### BACKGROUND

#### Air traffic environment

3.2.1 The air transport industry grew more rapidly than most other industries through the 1980s and 1990s. Between 1985 and 1995, air passenger travel and air freight on scheduled services grew at average annual rates of 5.0 and 7.6 per cent, respectively. Over this same period, aircraft departures and aircraft-kilometres grew at average rates of 3.7 per cent and 5.8 per cent, respectively. The annual changes in scheduled aircraft movements are illustrated in Figure 3-1.

#### The FANS Committee

3.2.2 Having considered the steady growth of international civil aviation preceding 1983, taking into account forecasts of traffic growth and perceiving that new technologies were on the horizon, the Council of ICAO at the time considered the future requirements of the civil aviation community. It determined that a thorough analysis and reassessment of the procedures and technologies that had so successfully served international civil aviation over the many years was needed. In further recognizing that the systems and procedures supporting civil aviation had reached their limits, the Council took an important decision at a pivotal juncture and established the Special Committee on Future Air Navigation Systems (FANS). The FANS Committee was tasked with studying, identifying and

assessing new technologies, including the use of satellites, and making recommendations for the future development of air navigation for civil aviation over a period of the order of 25 years.

3.2.3 The FANS Committee determined that it would be necessary to develop new systems that would overcome limitations of conventional systems and allow ATM to develop on a global scale. The future systems would be expected to evolve and become more responsive to the needs of users whose economic health would be directly related to the efficiency of these systems. The FANS Committee concluded that satellite technology offered a viable solution to overcome the shortcomings of conventional ground-based systems and to meet the future needs of the international civil aviation community.

3.2.4 The FANS Committee further recognized that the evolution of ATM on a global scale using new systems would require a multidisciplinary approach because of the close interrelationship and interdependence of its many elements. Understanding that coordination and institutional issues could eventually arise with new concepts, and realizing that planning would have to be carried out at the worldwide level, the FANS Committee recommended to the ICAO Council in its final report that a new committee be established to advise on the overall monitoring, coordination of development and transition planning. This would ensure that implementation of future CNS/ATM systems would take place on a global basis in a cost-effective and balanced manner, while still taking into account air navigation systems and geographical areas.

3.2.5 In July 1989, the ICAO Council, acting on the recommendation of the FANS Committee, established the Special Committee for the Monitoring and Coordination of Development and Transition Planning for the Future Air Navigation System (FANS Phase II).

3.2.6 In October 1993, the FANS Phase II Committee completed its work. The FANS Phase II Committee recognized that implementation of related technologies and expected benefits would not arrive overnight, but would rather evolve over a period of time, depending upon the present aviation infrastructures in the different States and regions, and the overall requirements of the aviation community. The FANS Phase II Committee also agreed that much of the technology they were considering was already becoming available and that work should begin by gathering information and, where possible, accruing early benefits using available technologies.

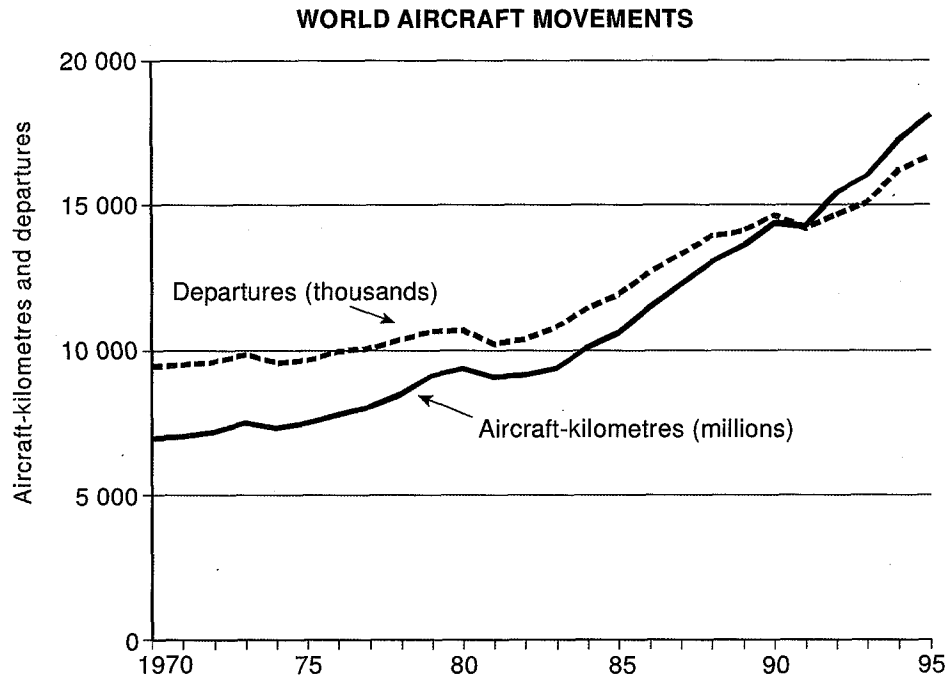

**Figure 3-1. Annual changes in scheduled aircraft movements**

### The Tenth Air Navigation Conference

3.2.7 In September 1991, 450 representatives from 85 States and 13 international organizations gathered at ICAO Headquarters in Montreal, Canada, at the Tenth Air Navigation Conference, to consider and endorse the concept for a future air navigation system as developed by the FANS Committees, that would meet the needs of the civil aviation community well into the next century. The FANS concept, which became known as the communications, navigation, surveillance/air traffic management (CNS/ATM) systems, involves a complex and interrelated set of technologies, dependent largely on satellites. CNS/ATM is the vision developed by ICAO with the full cooperation of all sectors of the aviation community to accommodate the future needs of international air transport.

### SHORTCOMINGS OF CONVENTIONAL SYSTEMS

3.2.8 The FANS Committee, early in its work, recognized that for an ideal worldwide air navigation system, the ultimate objective should be to provide a cost-effective and efficient system adaptable to all types of operations in as near four-dimensional freedom (space and

time) as their capability would permit. With this ideal in mind, it was recognized that the existing overall air navigation system and its subsystems suffered from a number of shortcomings in terms of their technical, operational, procedural, economic and implementation nature. After close analyses, the FANS Committee ascertained that the shortcomings of current systems (FANS I conducted its work between 1983 and 1988) around the world amounted to essentially three factors:

- a) the propagation limitations of current line-of-sight systems;
- b) the difficulty, caused by a variety of reasons, to implement current CNS systems and operate them in a consistent manner in large parts of the world; and
- c) the limitations of voice communications and the lack of digital air-ground data interchange systems to support automated systems in the air and on the ground.

3.2.9 Although the effects of the limitations were not the same for every part of the world, the FANS Committee



foresaw that one or more of these factors inhibited the desired development of ATM almost everywhere. As the limitations were inherent to the existing systems themselves, the FANS Committee realized that there was little likelihood that the global ATS system of the time could be substantially improved. New approaches were necessary by which the limitations could be surmounted and which would further permit ATS systems to evolve into an ATM system more responsive to the needs of the users. CNS/ATM systems, therefore, would have to allow for a considerable improvement in safety, efficiency and flexibility on a global basis.

### A BRIEF LOOK AT CNS/ATM

3.2.10 The four main elements of CNS/ATM systems are summarized below and are dealt with in detail in the *Global Air Navigation Plan for CNS/ATM Systems*, 2nd edition (Doc 9750).

#### Communications

- In CNS/ATM systems, the transmission of voice will, initially, continue to take place over existing very high frequency (VHF) channels; however, these same VHF channels will increasingly be used to transmit *digital data*.
- Satellite data and voice communications, capable of global coverage, are also being introduced along with data transmission over high frequency (HF) channels.
- The secondary surveillance radar (SSR) Mode S, which is increasingly being used for surveillance in high-density airspace, has the capability of transmitting digital data between air and ground.
- An aeronautical telecommunication network (ATN) will provide for the interchange of digital data between end-users over dissimilar air-ground and ground-ground communications subnetworks.

The regular use of data transmission for ATM purposes will introduce many changes in the way that communications between air and ground take place, and at the same time offer many new possibilities and opportunities.

The benefits expected from the future communications systems lie in the fact that they will allow more direct and

efficient linkages between ground and airborne *automated* systems in conjunction with pilot/controller communications. In fact, digital data link can be seen as the key to the development of new ATM concepts leading to the achievement of real benefits.

#### Navigation

- Improvements in navigation include the progressive introduction of area navigation (RNAV), supported by an appropriate combination of global navigation satellite system (GNSS), self-contained navigation systems (IRU/IRS) and conventional ground-based navigation aids. The ultimate goal is a transition to GNSS that eliminates the requirement for ground-based aids, although the vulnerability of GNSS to interference may require the retention of some ground aids in specific areas.
- GNSS provides for global navigational coverage and is being used for oceanic, en-route and terminal navigation and for non-precision approaches. With appropriate augmentation systems and related procedures, GNSS supports approaches with vertical guidance and precision approaches. GNSS, as specified in Annex 10, provides a high-integrity, high-accuracy and all-weather global navigation service. The full implementation of GNSS will enable aircraft to navigate in all types of airspace, in any part of the world, using on-board avionics to receive and interpret satellite signals.

#### Surveillance

- Traditional SSR modes will continue to be used, along with the gradual introduction of Mode S in both terminal areas and high-density continental airspace.
- The major breakthrough, however, is with the implementation of automatic dependent surveillance (ADS). ADS allows aircraft to automatically transmit their position, and other data, such as heading, speed and other useful information contained in the flight management system (FMS), via satellite or other communications links, to an air traffic control (ATC) unit where the position of the aircraft is displayed somewhat like that on a radar display. Benefits would be derived quickly through ADS in oceanic and some continental areas that currently have no radar coverage.

ADS can also be seen as an application that represents the true merging of communications and navigation technologies, and, along with ground system automation enhancements, will allow for the introduction of significant improvements for ATM, especially in oceanic airspace. Software is currently being developed that would allow this data to be used directly by ground computers to detect and resolve conflicts.

ADS-broadcast (ADS-B) is another concept for dissemination of aircraft position information. Using this method, aircraft periodically broadcast their position to other aircraft as well as to ground systems. Any user, whether airborne or on the ground, within range of the broadcast, receives and processes the information. All users of the system have real-time access to precisely the same data, via similar displays, allowing a vast improvement in traffic situational awareness.

#### *Air traffic management (ATM)*

- In considering implementation of new communications, navigation and surveillance systems and all of the expected improvements, it can be seen that the overall main beneficiary is likely to be ATM. More appropriately, the advancements in CNS technologies will serve to support ATM. When referring to ATM in the future concept, much more than just air traffic control is meant. In fact, ATM refers to a system's concept of management on a much broader scale, which includes ATS, air traffic flow management (ATFM), airspace management (ASM) and the ATM-related aspects of flight operations.

An integrated global ATM system should fully exploit the introduction of new CNS technologies through international harmonization of Standards and procedures. Ultimately, this would enable aircraft operators to conduct their flights in accordance with their preferred trajectories, dynamically adjusted, in the optimum and most cost-efficient manner.

3.2.11 The ICAO CNS/ATM systems concept is widely seen as advantageous because it permits the enhancement of safety. Improved reliability of the aeronautical mobile satellite communications system, for example, will mean more complete and less interrupted ATS communications in some parts of the world. In addition, ADS and data communications systems facilitate improved conflict detection and resolution and assist the controller by providing advice on conflict resolution. More rapid and detailed

information on weather warnings such as storm alerts will also contribute to the safety and effectiveness of flight operations.

3.2.12 CNS/ATM systems will improve the handling and transfer of information, extend surveillance using ADS and improve navigational accuracy. This will lead, among other things, to reductions in separation between aircraft, allowing for an increase in airspace capacity.

3.2.13 Advanced CNS/ATM systems will also see the implementation of ground-based computerized systems to support increases in traffic. These ground-based systems will exchange data directly with FMS aboard aircraft through a data link. This will benefit the ATM provider and airspace user by enabling improved conflict detection and resolution through intelligent processing, providing for the automatic generation and transmission of conflict-free clearances, as well as offering the means to adapt quickly to changing traffic requirements. As a result, the ATM system will be better able to accommodate an aircraft's preferred flight profile and help aircraft operators to achieve reduced flight operating costs and delays.

### **3.3 AUTOMATION IN ADVANCED AVIATION SYSTEMS**

3.3.1 One major issue in advanced aviation systems (including the CNS/ATM system) is the impact of automation and the application of advanced technology on the human operator. In order to be effective, automation must meet the needs and constraints of designers, purchasers (i.e. air traffic services providers and/or civil aviation authorities) and users. It is, therefore, essential to provide guidelines for the design and use of automation in highly advanced technology systems including the CNS/ATM system. What roles should automation play in advanced systems, how much authority should it have, how will it interact with the human operator and what role should be reserved for the human are but a few of the many questions that should be answered during conceptual system design.

#### **The role of the human operator in highly automated systems**

3.3.2 Technology has advanced to an extent for computers (automation) to be able to perform nearly all of the continuous air traffic control and surveillance as well as aircraft navigational tasks of the aviation system. Why, then, is the human needed in such systems? Couldn't

automation be constructed to accomplish all the discrete tasks of the human operator? Would it not be easier and even cheaper to design highly reliable automata that could do the entire job without worrying about accommodating a human operator?

3.3.3 Many system designers view humans as unreliable and inefficient and think that they should be eliminated from the system. (This viewpoint is fuelled by the promise of artificial intelligence and recently introduced advanced automation.) It is unrealistic to think that machine functioning will entirely replace human functioning<sup>1</sup> Automation is almost always introduced with the expectation of reducing human error and workload, but what frequently happens is that the potential for error is simply relocated. More often than not, automation does not replace people in systems; rather, it places the person in a different, and in many cases, more demanding role.<sup>2</sup>

3.3.4 As an example, it is widely claimed that a prerequisite for increasing airspace capacity is to change the role of the air traffic controller from controlling every aircraft individually to managing a larger (or wider) airspace. In future ATC architectures, automated tools for conflict detection and resolution are supposed to play a greater role in the routine provision of separation between aircraft. Controller intervention will be necessary only when the automation is unable to resolve developing situations, when traffic density precludes route flexibility, or for other safety reasons. In other words, the traditional controller becomes an exception manager who will have to resolve conflicts when aircraft or computers are unable to and take over control when the airspace gets too busy or when other critical parameters are exceeded.

3.3.5 But as stipulated by Dekker and Woods (1999), management by exception traps human controllers in a dilemma: intervening early provides only thin ground for justifying restrictions and creates controller workload problems (and compromises larger air traffic system goals) while intervening late leaves little time for actually resolving the problem, which by then will be well underway (thereby compromising larger air traffic system goals). In summary, intervening early would be difficult, and intervening late would be difficult, although for different reasons. Management by exception seems to put the future controller in a fundamental double bind.

3.3.6 The aviation system consists of many variables that are highly dynamic and not fully predictable. Real-time responses to developing situations are what assure the safe operation of the whole aviation system. The basic

difference in the way humans and computers respond to situations could mean the difference between a reliable (safe) and an unreliable (unsafe) aviation system. Human response involves the use and coordination of eyes, ears and speech and the ability to respond to unexpected problems through initiative and common sense. Computers depend on the *right programme* being installed to ensure that the *right* action is taken at the *right time*. The inability of automation designers to engineer a programme that can deal with all presumed eventualities and situations in the aviation system, and the uncontrollable variability of the environment are some of the major difficulties of computerizing all the tasks of the aviation system. The reality is: if automation is faced with a situation it is not programmed to handle, it fails. Automation can also fail in unpredictable ways. Minor system or procedural anomalies can cause unexpected effects that must be resolved in real time, as in the air traffic control breakdowns in the UK NATS' Swanwick en route centre (NERC) in 2002 and the breakdown of the flight data processing systems in the Tokyo Air Traffic Control Centre in 2003. Considering these limitations, it is not very difficult to see that an automation-centred aviation system can easily spell disaster to the whole aviation infrastructure.

3.3.7 Although humans are far from being perfect sensors, decision-makers and controllers, they possess several invaluable attributes, the most significant of which are their ability to reason effectively in the face of uncertainty and their capacity for abstraction and conceptual analysis of a problem. Faced with a new situation, humans, unlike automatons, do not just fail; they cope with the situation and are capable of solving it successfully. Humans thus provide to the aviation system a degree of flexibility that cannot now and may never be attained by computational systems. Humans are *intelligent*: they possess the ability to respond quickly and successfully to new situations. Computers, the dominant automatons of the ATC system, cannot do this except in narrowly defined, well understood domains and situations.<sup>3</sup>

3.3.8 Automation should be considered to be a tool or resource, a device, system or method which enables the human to accomplish some task that might otherwise be difficult or impossible, or which the human can direct to carry out more or less independently a task that would otherwise require increased human attention or effort. The word "tool" does not preclude the possibility that the tool may have some degree of intelligence — some capacity to learn and then to proceed independently to accomplish a task. Automation is simply one of many resources available to the human operator, who retains the responsibility for management and direction of the overall system.

3.3.9 An emerging term to denote a more intelligent design form of automation is “cooperative human-machine architecture”. According to Dekker and Woods (1999), the active partner in a well coordinated human-machine team (which in management by exception would often be the machine) would not sound threshold crossing alarms to signal the end of its problem-solving capability. It would instead continuously comment on the difficulty or increasing effort needed to keep relevant parameters on target. The (human) supervisor could ask about the nature of the difficulty, investigate the problem, and perhaps finally intervene to achieve overall safety goals.

3.3.10 In order to build such cooperative human-machine architecture for ATC it first should be determined what levels and modes of interaction will be meaningful to controllers and in which situations. In some cases controllers may want to take very detailed control of some portion of a problem, specifying exactly what decisions are made and in what sequence, while in others the controllers may want to make very general, high-level corrections to the course of events.

3.3.11 Considering automation a resource is a line of thinking that has been well understood and precisely defined by the aviation Human Factors community, to the extent that philosophies have been developed by some organizations in the industry to demarcate the function and responsibilities of the two elements (human operators and automation) in the system. A very good example of such a philosophy as adopted by one airline states:<sup>4</sup>

The word “automation”, where it appears in this statement, shall mean the replacement of a human function, either manual or cognitive, with a machine function. This definition applies to all levels of automation in all airplanes flown by this airline. The purpose of automation is to aid the pilot in doing his or her job.

The pilot is the most complex, capable and flexible component of the air transport system, and as such is best suited to determine the optional use of resources in any given situation.

Pilots must be proficient in operating their airplanes in all levels of automation. They must be knowledgeable in the selection of the appropriate degree of automation, and must have the skills needed to move from one level of automation to another.

Automation should be used at the level most appropriate to enhance the priorities of Safety, Passenger Comfort, Public Relations, Schedule and Economy, as stated in the Flight Operations Policy Manual.

In order to achieve the above priorities, all Delta Air Lines training programs, training devices, procedures, checklists, aircraft and equipment acquisitions, manuals, quality control programs, standardization, supporting documents and the day-to-day operation of Delta aircraft shall be in accordance with this statement of philosophy.

3.3.12 Introducing such an automation philosophy into aviation operations is beneficial since by defining how and when automation is to be used, it demarcates the boundary of human-machine responsibilities and thus promotes safety and efficiency in the system. It should be realized that an automation philosophy is not just linked to existing equipment. It can also be useful for an aviation organization’s overall procedure design, training development and equipment procurement, and it should not be made into a set of detailed procedures. These procedures may have to change with the arrival of new equipment while the philosophy remains the same. Last but not least, it must also be consistent with the cultural context in which the organization operates.

#### **CNS/ATM system automation**

3.3.13 The core of the benefits of the CNS/ATM system will be derived from automation intended to reduce or eliminate constraints imposed on the system. Data bases describing current and projected levels of demand and capacity resources, and sophisticated automated models that accurately predict congestion and delay will, in the future, be used to formulate effective real-time strategies for coping with excess demand. Automation will play a central role in establishing negotiation processes between the aircraft flight management computer systems and the ground-based air traffic management process, to define a new trajectory that best meets the user’s objective and satisfies ATM constraints. The human operator, however, should decide the outcome of the negotiation and its implementation. Similarly, when the ground-based management process recognizes a need to intervene in the cleared flight path of an aircraft, the ATM computer will negotiate with the flight management computer to determine a modification meeting ATM constraints with the least disruption to the user’s preferred trajectory. Automation can also probe each ADS position-and-intent report from an aircraft to detect potential conflicts with other aircraft, with hazardous weather or with restricted airspace.

3.3.14 The range of use of automated systems and automation is so central to the CNS/ATM systems that it will not be possible to derive the envisaged benefits of the CNS/ATM system or even implement it effectively without

the use of automation. It is clear that the possibilities being researched as a result of the introduction of the global CNS/ATM system range well beyond what is strictly envisaged at present and further development may strictly depend on more and more automation.

3.3.15 Automation has been gradually introduced in the aviation system. Flight deck automation has made aircraft operations safer and more efficient by ensuring more precise flight manoeuvres, providing display flexibility, and optimizing cockpit space. Many modern ATC systems include automated functions, for example in data gathering and processing, which are fully automated with no direct human intervention. Computerized data bases and electronic data displays have enhanced data exchange, the introduction of colour radar systems have allowed a greater measure of control, and the computerization of Air Traffic Flow Management (ATFM) has proved to be an essential element to efficiently deal with the various flow control rates and increases in traffic demand.

3.3.16 For the purpose of this chapter, automation refers to a system or method in which many of the processes of production are automatically performed or controlled by self operating machines, electronic devices, etc.<sup>5</sup> The concern is with automation of advanced aviation-related technology and in particular with Human Factors issues in CNS/ATM systems development and application. Automation is essential to the progressive evolution of the CNS/ATM systems and is expected to play a commanding role in future development of aviation technology. As such, its progressive introduction, therefore, is most desirable.

3.3.17 The techniques of air traffic management are constantly changing. New data link and satellite communication methods are evolving, the quality of radar and data processing is improving, collision avoidance systems are being developed, reduced vertical separation minima (RVSM) above FL290 are being implemented, direct routing of aircraft between departure and arrival airports instead of via airways is being explored, and highly advanced air navigation systems are being researched and developed. More and more possibilities intended to increase the benefits of the concept in a wider scale are also being discovered and introduced.

3.3.18 Further options offered by such technological advances have to be considered in terms of safety, efficiency, cost effectiveness and compatibility with human capabilities and limitations. These advances change the procedures and practices of the global aviation system, the working environment and the role of pilots, air traffic controllers, dispatchers, aircraft maintenance technicians, etc., presenting all concerned with the challenge not to

overlook the Human Factors issues involved. ICAO Annex 11 requires that whenever significant changes to operational procedures or regulations are contemplated, a system safety assessment must be conducted. The objective of such assessment is to identify any safety deficiencies in the proposed changes before they are implemented, and to ensure that the new procedures are *error tolerant* so that the consequences of human or technological failure are not catastrophic. Human Factors consideration in the design and development of new systems can assure that the paramount requirement of safety is never compromised in the whole system, but maintained and enhanced throughout all future challenges.

3.3.19 Development in CNS/ATM systems will seek to do more with less, by designing and procuring air traffic management systems that are highly automated. Increased automation in aviation is inevitable. The issue is therefore about *when*, *where* and *how* automation should be implemented, not *if* it should be introduced. Properly used and employed, automation is a great asset. It can aid efficiency, improve safety, help to prevent errors and increase reliability. The task is to ensure that this potential is realized by matching automated aids with human capabilities and by mutual adaptation of human and machine to take full advantage of the relative strengths of each. In aviation automated systems, the human (pilot, controller, etc.), who is charged with the ultimate responsibility for the safe operation of the system must remain the key element of the system: automation or the machine must assist the human to achieve the overall objective, never the contrary.

3.3.20 A major design challenge in the development of air traffic management procedures and techniques using new technologies is to realize system improvements that are centred on the human operator. Information provided to the human operator and the tasks assigned must be consistent with the human's management and control responsibilities as well as the innate characteristics and capabilities of human beings. Any technological advance in the aviation system, including the CNS/ATM system, should therefore take into account the human-machine relationship early in its design process and development. If account is not taken at this stage, the system may not be used as intended, prejudicing the efficiency or safety of the whole system. Automation must be designed to assist and augment the capabilities of the human managers; it should, as much as possible, be *human-centred*. As basic understanding of Human Factors improves, and as facilities for testing the Human Factors aspects of system designs become available, the design process can be expected to be more efficient.

### Issues and concerns in CNS/ATM systems automation

3.3.21 CNS/ATM systems are intended to be a world-wide evolution of communications, navigation and surveillance techniques into a largely satellite-based system. As such, they entail a continuous increase of the level of automation in aviation operations. Optimum use of automation both in the aircraft and on the ground (air traffic control, dispatch and maintenance) is desired to permit high efficiency information flow. The Automatic Dependence Surveillance data can be used by the automated air traffic management system to present a traffic display with as much information as required to the operator. To increase capacity and reduce congestion, airports and airspaces must be treated as an integrated system resource, with optimal interaction between system elements, aircraft, the ground infrastructure, and most importantly, the human operators of the system.

3.3.22 In some States, extensive research is being done on improvements to air safety through the introduction of air-ground data links replacing the majority of pilot/controller voice communications. It should, however, be recognized that voice communication will still be required, at least for emergency and non-routine communications. Controller – Pilot Data Link Communication (CPDLC) is considered to offer great potential in reducing human error while providing for increased airspace capacity to accommodate future growth in air traffic. This, however, could involve changes in the human-machine interface which in the future may include increased use of artificial intelligence to assist the pilot and the controller in the decision-making process. Also, as evidenced by experience in the South Pacific, CPDLC introduces opportunities for errors in places in the system where they did not exist before (see 3.3.3).

3.3.23 All forms of automated assistance for the human operator must be highly reliable, but this may also induce complacency. Human expertise may gradually be lost and if the machine fails, the human operator may accept an inappropriate solution or become unable to formulate a satisfactory alternative. The most appropriate forms of human-machine relationship depend on the type of task which is automated and particularly on the interaction between planning and executive functions.

3.3.24 In the air traffic management environment, it is highly accepted that the performance of routine ATC tasks aids memory, which is not the case if these tasks are done automatically for the controller. Scientific studies have

shown that, in order to form a mental picture of the traffic situation, controllers derive a lot of their situational awareness by speaking to the aircraft and by making annotations on paper strips or making inputs (in more automated systems).<sup>6</sup> Verbal and written (or keyboard) inputs keep people “in the loop” and allow active updating of the mental picture and situational awareness in its widest sense.<sup>7</sup> It is believed that the automation of data can lead to deficiencies in human performance, since it can deprive the controller of important information about the reliability and durability of information. Automation may well reduce the effort required to perform certain tasks and the stress associated with them, but may also lead to loss of job satisfaction by taking away some of the intrinsic interests of the job and the perceived control over certain functions.

3.3.25 There is enough information, both from safety deficiencies information systems and from accident reports, to illustrate the impact of the technology-centred approach to automation. More than 60 concerns relating to automation were identified by a subcommittee of the Human Behaviour Technology Committee established by the Society of Automotive Engineers (SAE) to consider flight deck automation in 1985. The majority of these concerns are as relevant to the air traffic control environment as they are to the flight deck. A brief presentation of such concerns includes:<sup>8</sup>

- **Loss of systems awareness** may occur when the human operator is unaware of the basic capabilities and limitations of automated systems, or develops erroneous ideas of how systems perform in particular situations.
- **Poor interface design.** Automation changes what is transmitted through the human-machine interface, either leading to some information not being transmitted at all or the format of the transmitted information being changed. Traditionally, most information has been conveyed from the machine to the human by means of visual displays and from the human to the machine by means of input devices and controls. Poor interface design may also combine with the time required for the human to take over from automation and may become an important factor, by reducing the quality of execution or practice of an event due to lack of warmup.
- **Attitudes towards automation** could best be expressed as an indication of frustration over the operation of automated systems in a non-user-friendly environment, although improvements in

the human-machine interface would probably reduce this feeling to some extent. Wherever introduced, automation has not been uncritically accepted by those who are meant to operate it. Some aspects of automation are accepted while others are rejected (in some cases because operators did not operate the equipment acceptably in the real world environment). Acceptance of automation may also be affected by factors related to the culture of the organization to which employees belong. Poor relationships with management, employee perceptions of having had no choice in the decision to accept automation, and lack of involvement in the development of automation are other examples of factors that may negatively affect the acceptance of automation. These factors may operate independently of the quality of the automation provided to the employees.

- **Motivation and job satisfaction** involve problem areas such as loss of the controller's feeling of importance, the perceived loss in the value of professional skills, and the absence of feedback about personal performance. Many operators feel that their main source of satisfaction in their job lies in its intrinsic interest to them. They believe that the challenge of the job is one of the main reasons they enjoy their profession. A takeover by automation to the point that job satisfaction is reduced can lead to boredom and general discontent.
- **Over-reliance** on automation occurs because it is easy to become accustomed to the new automated systems' usefulness and quality. A tendency to use automation to cope with rapidly changing circumstances may develop even when there is not enough time to enter new data into the computer. When things go wrong, there may also be a reluctance by the human to discard the automation and take over.
- **Systematic decision errors.** Humans may depart from optimal decision-making practices, particularly under time pressure or other stress. The existence of human biases may further limit the ability of humans to make optimal decisions. One approach to reduce or eliminate biased decision-making tendencies is to use automated decision-making aids at the time decisions are required. In such a system, humans adopt one of two strategies: accept or reject the machine recommendation. Although the benefits of automated decision-making aids are theoretically evident, they still remain to be conclusively demonstrated.
- **Boredom and automation complacency** may occur if a major portion of air traffic management is completely automated, and human operators are lulled into inattention. In the particular case of complacency, humans are likely to become so confident that the automatic systems will work effectively that they become less vigilant or excessively tolerant of errors in the system's performance.
- **Automation intimidation** results in part because of an increase in system components. The result is a reliability problem, since the more components there are, the more likely it will be that one will fail. However, humans remain reluctant to interfere with automated processes, in spite of some evidence of malfunction. This is partly due to inadequate training and partly to other pressures.
- **Distrust** normally occurs because the assessment of a particular situation by the human differs from the automated system. If the system does not perform in the same manner as a human would do, or in the manner the controller expects, it can lead to either inappropriate action or concern on the part of the human. This can also occur if the human is not adequately trained. Distrust can be aggravated by flaws in system design which lead to nuisance warnings.
- **Mode confusion and mode misapplication** are results of the many possibilities offered by automation, as well as of inadequate training. It is possible with a new computer technology for the controller to assume that the system is operating under a certain management mode when in fact it is not.
- **Workload.** The advance of automation has been based partly on the assumption that workload would be reduced, but there is evidence to suspect that this goal has yet to be achieved. In the air traffic control environment, additional working practices such as data entry/retrieval methods may actually increase workload. For example, merely automating certain aspects of an ATC system will not necessarily enable the air traffic control officer to handle more traffic. Automation should be directed at removing non-essential tasks, thereby allowing the controller to concentrate on more important tasks, such as monitoring or directly controlling the system and resolving conflicts.
- **Team function.** The team roles and functions in automated systems differ from those which can be

exercised in manual systems. As an example, controllers in more automated systems are more self-sufficient and autonomous and fulfil more tasks by interacting with the machine rather than with colleagues or with pilots. There is less speech and more keying. This affects the feasibility and development of traditional team functions such as supervision, assistance, assessment and on-the-job training. When jobs are done by members of a closely coordinated team, a consensus about the relative merits of individual performance can form the basis not only of professional respect and trust but also of promotions or assignments of further responsibilities. The subject of changes in team roles and functions is one of the items that should be addressed in Team Resource Management (TRM) training for air traffic services personnel.

3.3.26 The technology-centred approach in the automation of highly advanced technologies such as the nuclear power plant industry, chemical industry, civil aviation, space technology, etc., resulted in accidents with a great loss of lives and property. Basically, such accidents were an outcome of human-machine incompatibilities. Since the technology was easily available, engineering-based solutions to human error were implemented without due consideration of human capabilities and limitations. Technology-centred automation may be based on the designer's view that the human operator is unreliable and inefficient, and so should be eliminated from the system. However, two ironies of this approach have been identified:<sup>9</sup> one is that designer errors can be a major source of operating problems; the other is that the designer who tries to eliminate the operator still leaves the operator to do the tasks which the designer does not know how to automate. To this we can add the fact that automation is not, after all, infallible and usually fails in mysterious and unpredictable ways. It is for this reason that there are increasing calls for a human-centred approach which takes all the elements, and especially the human element, into due consideration. Hard lessons have been learned in the automation of aviation systems in the past. Cockpit automation stands as an example. However, in cockpit automation, we can now say that — albeit with notorious exceptions — there is a return to human-centred automation, which is a positive and encouraging trend strongly endorsed by ICAO. It is hoped that lessons learned in the past are applied to all new advanced technology systems so that known mistakes will not be committed again.

3.3.27 A further new aspect of the introduction of CNS/ATM technology that may be of special relevance to regulatory authorities is the interaction between ground and

airborne systems. Traditionally these systems were considered to be stand-alone systems, but in an advanced technology environment there increasingly is an automated exchange of information between the systems based on which safety-related actions may or may not be taken by the respective operators. This may have implications for certification requirements for the ground-based system components across States.

### 3.4 HUMAN-CENTRED TECHNOLOGY

#### A concept of human-centred automation

3.4.1 "Human-centred automation" is a systems concept, meaning *automation designed to work cooperatively with human operators in pursuit of the stated objectives*. Its focus is an assortment of automated systems designed to assist human operators, controllers or managers to meet their responsibilities. The quality and effectiveness of the human-centred automation system is a function of the degree to which the combined system takes advantage of the strengths and compensates for the weaknesses of both elements. To better understand the concept of human-centred automation we may define a fully autonomous, robotic system as non-human-centred — the human has no critical role in such a system once it is designed and is made operational. Conversely, automation has no role to play in a fully manual system.

3.4.2 None of today's complex human-machine systems are at either extreme. Nearly all systems provide automatic devices to assist the human in performing a defined set of tasks and reserve certain functions solely for the human operator. No one expects future advanced aviation systems to be fully robotized, discarding the human element in its operation. They are also not expected to be operated without the assistance of some kind of automation. In fact, even today, both humans and machines are responsible for the safe operation of the aviation system. The following classification for increasing degrees of automation has been proposed (Billings, 1991):

- Direct manual control
- Assisted manual control
- Shared control
- Management by delegation



- Management by consent
- Management by exception, and
- Autonomous operation.

As was discussed in the previous chapter, future growth in the aviation system will require more automation. Technology advancement in the system may well be based on the way we handle information and utilize automation. Information technology in aviation systems will foster profound changes in areas such as communications (air/ground, air/air, ground/ground), panel displays (flat, head-up, head-down), voice interactive techniques, data link, etc. Automation technology will likewise foster significant progress in areas such as flight control, air traffic control, digital control systems, fly by wire, etc.

3.4.3 The trend toward more information, greater complexity and more automated operation has the potential to isolate the human operators from the operation and to decrease their awareness of the state and situation of the system being operated. There are many reasons, several of which were discussed earlier, why system designers should consider Human Factors from the very beginning of the design process. Investigations of all major accidents which occurred within the last two decades of the 20th century in organizations using highly advanced technology (Three Mile Island and Chernobyl — nuclear power technology, Tenerife — civil aviation, Bhopal — chemical industry, Challenger — space technology) showed that improper or flawed interfaces between human operators and technology were among the causal factors. Human error in those accidents was induced by poor design, flawed procedures, improper training, imperfect organizations, or other systemic deficiencies. The key issue here is that human error or degraded human performance is induced by factors which can be avoided at the proper stage.<sup>10</sup> Systems design which might induce human error can be avoided by better Human Factors design decisions from the very beginning of system design to the very end.

3.4.4 The goal of human-centred automation is to influence the design of human-machine systems in advanced technology so that human capabilities and limitations are considered from the early stages of the design process and are accounted for in the final design. A design that does not consider Human Factors issues cannot result in an optimal system that enhances productivity, safety and job satisfaction. Lack of recognition of the unique benefits to be derived from human-centred automation may perhaps be the main reason why Human Factors technology has seldom been applied early or integrated routinely into the

system design process. There are, however, several very important payoffs for early investment in Human Factors.<sup>11</sup>

### **Human-centred technology (automation) prevents disasters and accidents**

3.4.5 Human or operator error has arguably been identified as the primary causal factor of accidents and incidents. Speaking of systems in general, about 60 to 80 per cent of accidents are attributed to operator error.<sup>12</sup> However, research applied to accident investigations casts doubt on such findings, by demonstrating that in most cases where human operators are said to be the primary causal factor of an accident, they are confronted by unexpected and unusually opaque technological interactions resulting in unforeseen failures. Analysis of several high-technology accidents, initially attributed to operator error, reveals that most of the human error identified is induced by other factors. It is therefore essential to differentiate systemic-induced human errors from those which are truly the consequence of deficient operator performance. Accident-inducing factors include poor hardware design, poor human-machine integration, inadequate training, and poor management practices and flawed organizational design. If the humans involved in design, manufacture, training and management are included in the wider picture, it could be argued that “human error” plays a role in nearly every accident or incident. However, for analytical purposes it is necessary to distinguish between latent conditions (by designers, manufacturers, trainers, managers) and active failures (by operators), and it is important to realize that active failures which result in (near) catastrophic outcomes can only do so because of a series of latent failures already present in the system (see also 3.6.1 and 3.6.2).

3.4.6 The cost associated with lost lives and injuries due to the lack of proper Human Factors consideration during design and certification of the technology cannot be overstated. Research has clearly shown that technology-produced problems will not be eliminated by more technology, especially in highly advanced systems where human operators are expected to bear full responsibility for their own as well as the automated systems’ actions.

... Most of us choose to think of the human role in our sophisticated technological society as a minor part of the equation. We accept a walk-on part in the modern world and give the machines, the systems, the lead. Again and again, in the wake of catastrophe, we look for solutions that will correct “it” rather than “us.” ... But no machine is more trustworthy than the humans who made it and operate it. So we are stuck. Stuck here in the high-risk world with our

own low-tech species, like it or not. No mechanical system can ever be more perfect than the sum of its very Human Factors.<sup>14</sup>

3.4.7 Human-centred technology (automation), by integrating Human Factors considerations into the system design process, can resolve human error issues in highly advanced automated systems, thereby pre-empting future disasters and accidents.

#### Human-centred technology (automation) reduces costs

3.4.8 Costs associated with the introduction of new technology have mostly been determined during the concept exploration phase of system development. To keep costs down, Human Factors considerations are often left out of initial design considerations (in the hope that personnel training will make up for design deficiencies). The result has been the multiplication of downstream costs (training, operation and maintenance) far beyond the initial savings. Changes to ensure that trained personnel can operate the system, after system design has been set, are more difficult and costly.<sup>15</sup> This is illustrated by the graph in Figure 3-2.

3.4.9 There is a front-end cost associated with human-centred technology (automation) in the conceptual stages, but, compared to the everyday operating costs induced by inadequate design, it is negligible.

There is an "iron law" that should never be ignored. To consider Human Factors properly at the design and certification stage is costly, but the cost is paid only once. If the operator must compensate for incorrect design in his training program, the price must be paid every day. And what is worse, we can never be sure that when the chips are down, the correct response will be made.<sup>16</sup>

3.4.10 In addition to the unnecessary costs associated with obvious breakdowns in the machine and human interface, there is an even greater cost associated with everyday degradation in overall system performance. Because of inadequate consideration of the human role during conceptual design, systems frequently do not perform as expected.

3.4.11 Systems that employ human-centred technology and integrate human capabilities, limitations and expectations into system design are easier to learn and operate, thus considerably reducing the ultimate investment

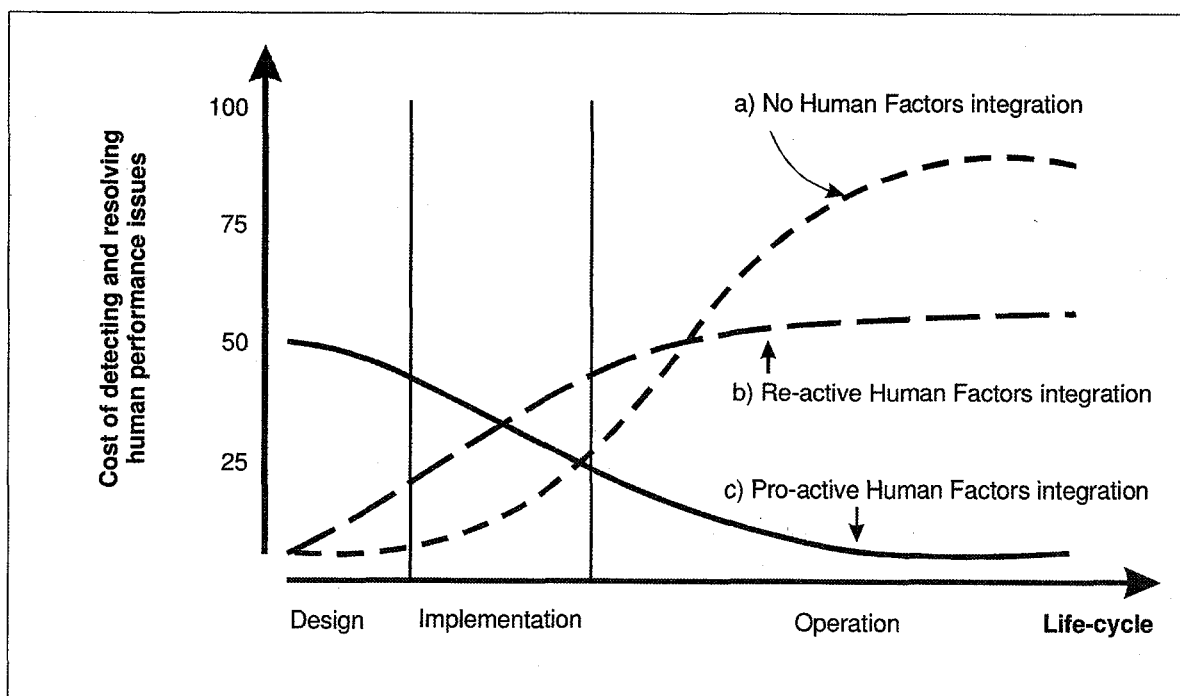

Figure 3-2. Comparison of the evolution of costs associated with the introduction of new technology with or without integration of Human Factors considerations.

in training and operating costs. Human-centred automation design is a one-time investment — it becomes a permanent part of the system at large. Conversely, investment in personnel, manpower and training are recurring costs. Thus, including Human Factors considerations in early system design is one sure way to avoid later costs.

3.4.12 Generally speaking, the lack of Human Factors considerations in the design and operation of systems will invariably cause inefficiencies, problems, accidents and the loss of property and lives.

3.4.13 The ability of humans to recognize and define the expected, to cope with the unexpected, to innovate and to reason by analogy when previous experience does not cover a new problem is what has made the aviation system robust, for there are still many circumstances that are neither directly controllable nor fully predictable. Each of these uniquely human attributes in addition to sub-cultural considerations is a compelling reason to retain the human in a central position in the design of appropriate automation for the advanced aviation system. Appropriate automation is automation which is suited to the user population and the environment in which it is used. As such it should be bound within certain principles: *the principles of human-centred automation*.<sup>17</sup>

### 3.5 PRINCIPLES OF HUMAN-CENTRED AUTOMATION

3.5.1 It has already been advanced that modern day automation is capable of performing nearly all of the functions envisaged in the aviation system both in the aircraft and on the ground. We have also shown that the human should, mainly in the interest of safety and economic advantages, remain the central focus in its design. Questions regarding automation principles will, of necessity, have to relate to the respective roles of the humans and machines. It is accepted that humans will retain responsibility for system safety. For this simple but most important reason they will also have to remain in full command of the automated systems for which they are responsible.

3.5.2 As introduced earlier, Billings (1997) proposes the various degrees of automation that may be at the disposal of air traffic controllers as a continuum (see Figure 3-3).

3.5.3 With respect to the question of which level of automation is appropriate for ATC, the following recommendation (*inter alia*) was made to the FAA by the Panel

on Human Factors in Air Traffic Control Automation (1998):

The panel recommends implementation of high levels of automation of decision and action selection for system tasks involving relatively little uncertainty and risk. However, for system tasks associated with greater uncertainty and risk, automation of decision and action selection should not proceed beyond the level of suggesting a preferred decision/action alternative. Any consideration for automation above this level must be designed to prevent: loss of vigilance, loss of situation awareness, degradation of operational skills, and degradation of teamwork and communication. Such designs should also ensure the ability to overcome or counteract complacency, recover from failure, and provide a means of conflict resolution if loss of separation occurs.

3.5.4 As long as human operators are required to be fully responsible for the safe operation of the system, tools (automation or otherwise) designed to assist them to undertake their responsibility should be designed with the human operator in mind. To effect this, regulators, designers, operators and users should employ guidelines, or principles, for the design and operation of automated systems envisaged to be employed in the system and assist the human operators to successfully undertake their responsibilities.

3.5.5 The application of these principles is central in the preliminary and final design processes of automated systems in highly advanced technologies. The core of the matter is that *automation is employed to assist human operators to undertake their responsibilities in the most safe, efficient, effective and economical manner*. It should never be the other way around. Questions raised in previous chapters on how much authority automation should have, how it will interact with the human operator, and what role should be reserved for the human can only be satisfied by the application of a set of principles during the design, development and operation of an automation system. Antoine de Sainte-Exupéry's observation that "the machine does not isolate man from the great problems of nature but plunges him more deeply into them" holds true now even more than it did during the late 1930s, when it was voiced.

3.5.6 Over time, progress in aviation safety has been hindered by piecemeal approaches. Pilots, controllers, designers, engineers, researchers, trainers and others in the aviation safety community have advocated solutions to safety deficiencies which are undoubtedly biased by their professional backgrounds. Such approaches have neglected to look into the big picture of aviation system safety, and have thus produced dedicated solutions to observed

Management Mode	Automation Functions	Human Functions
Autonomous operation	Fully autonomous operation; controller not usually informed. System may or may not be capable of being bypassed.	Controller has no active role in operation. Monitoring is limited to fault detection. Goals are self-defined; controller normally has no reason to intervene.
Management by exception	Essentially autonomous operation. Automatic decision selection. System informs controller and monitors responses.	Controller is informed of system intent; may intervene by reverting to lower level.
Management by consent	Decisions are made by automation. Controller must assent to decisions before implementation.	Controller must consent to decisions. Controller may select alternative decision options.
Management by delegation	Automation takes action only as directed by controller. Level of assistance is selectable.	Controller specifies strategy and may specify level of computer authority.
Assisted control	Control automation is not available. Processed radar imagery is available. Backup computer data is available.	Direct authority over all decisions; voice control and coordination.
Unassisted control	Complete computer failure; no assistance is available.	Procedural control of all traffic. Unaided decision making; voice communications.

very low ← level of automation → very high

very low ← level of automation → very high

Figure 3-3. Degrees of automation available to air traffic controllers

deficiencies and conveyed the notion that different activities within aviation take place in isolation. As mentioned elsewhere in this document, the principles of human-centred automation require that the industry embrace a system approach to the design of automation systems. The advantages of incorporating Human Factors considerations early in system design cannot be overstated.

- **The human bears the ultimate responsibility for the safety of the aviation system.** History has shown us over and over again that in a complex system, no matter how automated, the human has the last vote in deciding a critical issue and the human is the last line of defence in case of system breakdown. The importance of people in a technological society is further reflected in the concept of *pivotal people*. Pfeiffer (1989) emphasizes the irreplaceability of pivotal people in stressful environments like flight operations, air traffic control, and power utility grid control.<sup>19</sup> So when

discussing automation in the aviation system, it should always be borne in mind that if people are to function efficiently, effectively and safely, Human Factors considerations must be integrated in the system starting at the conceptual stage and not appended later on as part of a default decision.

- **The human operator must be in command.** For humans to assume ultimate responsibility for the safety of the system, they should be conferred with essentially unlimited authority to permit them to fulfil this ultimate responsibility. It has been unequivocally stated that even when the automated system is in full operation, “responsibility for safe operation of an aircraft remains with the pilot-in-command,” and “responsibility for separation between controlled aircraft remains with the controller.” If they are to retain the *responsibility* for safe operation or separation of aircraft, pilots and controllers must retain the *authority* to

command and control those operations. It is the fundamental tenet of the concept of human-centred automation that aviation systems (aircraft and ATC) automation exists to assist human operators (pilots and controllers) in carrying out their responsibilities as stated above. If this principle is not strictly observed, and if decisions are made by automated systems instead of by human operators, complicated and unavoidable liability issues may arise. This will obviously lead into consideration of the human operator's share of liability, which in turn will adversely affect human performance. Thus, a question of liability becomes a Human Factors issue by default. Human operators should never be held liable for failures or erroneous decisions unless they have full control and command of the system. The reasons are very simple — like any other machine, automation is subject to failure. Further, digital devices fail unpredictably and produce unpredictable manifestations of failures. The human's responsibilities include detecting such failures, correcting their manifestations, and continuing the operation safely until the automated systems can resume their normal functions. Since automation cannot be made failure-proof, automation must not be designed in such a way that it can subvert the exercise of the human operator's responsibilities.

- **To command effectively, the human operator must be involved.** To assume the ultimate responsibility and remain in command of the situation, human operators must be involved in the operation. They must have an active role, whether that role is

to actively control the system or to manage the human or machine resources to which control has been delegated. If humans are not actively involved, it is likely that they will be less efficient in reacting to critical system situations. Human-centred aviation system automation must be designed and operated in such a way that it does not permit the human operator to become too remote from operational details, by requiring of that operator meaningful and relevant tasks throughout the operation.

- **To be involved, the human must be informed.** Without information about the conduct of the operation, involvement becomes unpredictable and decisions, if they are made, become random. To maintain meaningful involvement, the human operator must have a continuing flow of essential information concerning the state and progress of the system controlled and the automation that is controlling it. The information must be consistent with the responsibilities of the human operator; it must include all the data necessary to support the human operator's involvement in the system. The human operators must be prominently informed at the level required to fulfil their responsibilities. The human operators must have enough information to be able to maintain state and situation awareness of the system. However, care must be taken not to overload them with more information than is necessary.
- **Functions must be automated only if there is a good reason for doing so.** There is a growing

### PRINCIPLES OF HUMAN-CENTRED AUTOMATION

The human bears the ultimate responsibility for the safety of the aviation system.

Therefore:

- The human must be in command.
- To command effectively, the human must be involved.
- To be involved, the human must be informed.
- Functions must be automated only if there is a good reason for doing so.
- The human must be able to monitor the automated system.
- Automated systems must, therefore, be predictable.
- Automated systems must be able to monitor the human operator.
- Each element of the system must have knowledge of the others' intent.
- Automation must be designed to be simple to learn and operate.

temptation to incorporate some new technology showpiece in a design just because it can be done rather than because it is necessary. In other words, designs may be driven by technological feasibility rather than the needs of the users who must operate and maintain the products of these designs. Automation of functions for no other reason except that it is technologically possible may result in the user's inability to effectively employ it for the benefit of the whole system. The question here should be "not whether a function can be automated, but whether it needs to be automated, taking into consideration the various Human Factors questions that may arise".<sup>20</sup>

- **The human must be able to monitor the automated system.** The ability to monitor the automated systems is necessary both to permit the human operator to remain on top of the situation, and also because automated systems are fallible. The human can be an effective monitor only if cognitive support is provided at the control station. Cognitive support refers to the human need for information to be ready for actions or decisions that may be required. In automated aviation systems, one essential information element is information concerning the automation. The human operator must be able, from information available, to determine that automation performance is, and in all likelihood will continue to be, appropriate to the desired system situation. In most aviation systems to date, the human operator is informed only if there is a discrepancy between or among the units responsible for a particular function, or a failure of those units sufficient to disrupt or disable the performance of the function. In those cases the operator is usually instructed to take over control of that function. To be able to do so without delay, it is necessary that the human operator be provided with information concerning the operations to date if these are not evident from the behaviour of the system controlled.
- **Automated systems must be predictable.** The human operator must be able to evaluate the performance of automated systems against an internal model formed through knowledge of the normal behaviour of the systems. Only if the systems normally behave in a predictable fashion can the human operator rapidly detect departures from normal behaviour and thus recognize failures in the automated systems. In so stating, it is important that not only the nominal behaviour, but also the range of allowable behaviour be known.

All unpredicted system behaviour must be treated as abnormal behaviour. To recognize this behaviour, the human operator must know exactly what to expect of the automation when it is performing correctly.

- **Automated systems must also be able to monitor the human operator.** Humans, of course, are not infallible either, and their failures may likewise be unpredictable. Because human operators are prone to errors, it is necessary that error detection, diagnosis and correction be integral parts of any automated aviation system. For this reason, it is necessary that human as well as machine performance be continuously monitored. Monitoring automation capable of questioning certain classes of operator's actions that can potentially compromise safety must be designed into the system.
- **Each element of the system must have knowledge of the others' intent.** In highly automated operations, one way to keep the human operator actively involved is to provide him or her with information concerning the *intent* of the automated system. That is, given the current decisions made or about to be made by the automated systems, what will the situation look like in the future. Essentially, the system should not only identify a potential problem but also suggest alternative solutions and show the implications of the action taken. Cross-monitoring can only be effective if the monitor understands what the operator of the monitored system is trying to accomplish. To obtain the benefit of effective monitoring, the intentions of the human operator or the automated systems must be known. The communication of intent makes it possible for all involved parties to work cooperatively to solve any problem that may arise. For example, many air traffic control problems occur simply because pilots do not understand what the controller is trying to accomplish, and the converse is also true. The automation of the ATC system cannot monitor human performance effectively unless it understands the operator's intent, and this is most important when the operation departs from normality.
- **Automation must be designed to be simple to learn and operate.** One of the major objectives of this chapter is to consider *how much automation is necessary, and why*. If systems are sufficiently simple (and this should always be a design goal) automation may not be needed. If tasks cannot be simplified, or are so time-critical that humans may

not be able to perform them effectively, automation may be the solution. Even then, simpler automation will permit simpler interfaces and better human understanding of the automated systems. Systems automation to date has not always been designed to be operated under difficult conditions in an unfavourable environment by overworked and distracted human operators of below-average ability. Yet these are precisely the conditions where the assistance of the automation system may be most needed. Simplicity, clarity and intuitiveness must be among the cornerstones of automation design, for they will make it a better and effective tool. Though training, strictly speaking, is not the province of the designers, training must be considered during the design of the components of the CNS/ATM systems and should reflect that design in practice. Good Human Factors Engineering (HFE) design is marked by an absence of problems in the use of a system by humans and its effects are thus invisible in the final operational system. Its contributions become an integral part of each component or subsystem and cannot be readily isolated from overall system functioning or credit to the HFE inputs.<sup>21</sup>

3.5.7 In establishing the basic guidelines for the principles of human-centred automation, it should be noted that no attempt has been made to cover the engineering aspects of Human Factors. The attempt is only to construct a philosophy of *human-centred automation*. By so doing, it is hoped to foster a dialogue which will further the overall goal of promoting a safe, orderly and economical aviation environment, integrating the best of both the human and the machine.

3.5.8 The principles of human-centred automation are intended to serve as a template so that every time automation is designed and introduced it can be filtered through the template rather than justified and defended anew.

### 3.6 QUALITIES OF HUMAN-CENTRED AUTOMATION

3.6.1 Human error has been identified as the major causal factor in most aviation accidents. The most widely held perception, by people in all walks of life, is that the error-causing human in those accidents is the “front-line operator”, simply stated as the pilot, air traffic controller, aircraft maintenance technician, etc. This perception, fuelled by the media and widely accepted by the public, has caused a lot of anxiety because it conceals the fact that the

evolution of modern technology has made it practically impossible for one individual — the front-line operator — to cause an accident *all alone*. In those accidents where operator error has initially been identified as the causal factor, researchers were able to prove that the operator has only triggered a chain of latent failures, long embedded in the system, waiting undetected, or ignored for one reason or another. A line of defence is built into modern-day technology making it practically impossible for a single action to cause an unprecedented accident unless the system has already been weakened by the elimination of those defences. It has been proved that design deficiencies, organizational and managerial shortcomings and many other latent failures were the root causes of many accidents attributed to the front-line operators, who in most cases do not survive the accidents to defend their actions.<sup>22</sup>

3.6.2 Other accidents, also attributed to front-line operators, were found to have been caused as a result of the interaction of humans with automated systems (a mismatch of the human and machine elements of the system). Automation systems are made by humans. As such they can also harbour unplanned-for errors from as early as their conception. The belief that better training will make up for unthought-of deficiencies in the design and development stage has proved to be fallible. More gadgets and the introduction of more complex technology has only succeeded to make the machines inoperable because Human Factors considerations were not included in the basic concept. Human Factors researchers and specialists, accident investigators and analysts, human behaviour specialists and experts studying human-machine interactions agree that making automation human-centred can solve most human error associated problems. More importantly, they believe that automation can be designed and used to make the system, as a whole, more resistant to and tolerant of human errors in design, implementation, and operation of the systems. This implies that if automation is to be an effective and valued component of the aviation system, it should also possess several qualities or characteristics. By defining the attributes of human-centred automation, it is hoped that the system is made inherently and distinctively useful to the human operator who, after all, is burdened with full responsibility for its safety — human and non-human. In defining the attributes an automation system should possess, the intent once more is to promote dialogue on the subject, thus furthering the orderly and safe operation of the entire air transportation system.

3.6.3 In discussing the attributes of human-centred automation, it should be clear that they are not mutually exclusive. An automated system that possesses some, or even many, of these qualities may still not be fully efficient if they are considered in isolation during design, for several

are interrelated. As in any engineering enterprise, it is necessary that the right compromise among the attributes be sought. To be sure that an effective compromise has been reached, the total system must be evaluated in actual or under a simulated operation by a variety of human operators of differing degrees of skill and experience. Such testing could be time-consuming and expensive and might often be conducted late in the development of the system; nevertheless, it is the only way to prove the safety and effectiveness of the automated concept. Thus, the first guideline in attributes of human-centred automation might simply be that *human-centred automation should possess these qualities in proper measure.*

3.6.4 Many of these attributes are to some extent bipolar, though not truly opposites,<sup>23</sup> and increasing the attention on certain qualities may require de-emphasizing others. In the manner suggested, human-centred automation must be:

Accountable	<----->	Subordinate
Predictable	<----->	Adaptable
Comprehensible	<----->	Flexible
Dependable	<----->	Informative
Error-resistant	<----->	Error tolerant

- **Human-centred automation must be accountable.** Automation must inform the human operator of its actions and be able to explain them on request. The human in command must be able to request and receive a justification for decisions taken by the automated system. This is a particular problem in aviation, as there may not be time for the human operator to evaluate several decisions (terrain avoidance, collision avoidance, etc.). Where possible, automation must anticipate the human operator's request and provide advance information (as TCAS intends to do by providing traffic advisories prior to requiring action to avoid an imminent hazard), or its rules of operation in a particular annunciated circumstance must be thoroughly understood by the human operator. It is particularly important that explanations provided by automation be cast in terms that make sense to the human operator; the level of abstraction of such explanations must be appropriate to the human operator's need for the explanation. In this context "accountable" means subject to giving a justifying analysis or explanation. The bipolar attribute of accountability is subordination. Great care must be taken to ensure that this cannot ever become insubordination.

- **Human-centred automation must be subordinate.** Except in predefined situations, automation should never assume command and, in those situations, it must be able to be countermanded easily. Automation, while an important tool, must remain subordinate to the human operator. There are situations in which it is accepted that automation should perform tasks autonomously, and more such tasks are expected to be implemented in the CNS/ATM system. As automation becomes more self-sufficient, capable and complex, it will be increasingly difficult for the human operators to remain aware of all actions being taken autonomously and thus increasingly difficult for them to be aware of exactly what the automation is doing and why. Such a situation will tend to compromise the command authority and responsibility of the human operators; more importantly, it may lead them to a position of extreme distrust of the automation system, which could compromise the integrity of the entire human-machine system. It is important to make questions such as "What is it doing?" and "Why is it doing that?" unnecessary.
- **Human-centred automation must be predictable.** Occurrences in which automation did not appear to behave predictably have, in the past, led to major repercussions due in large part to human operators' inherent distrust of things over which they do not have control. Here again, the level of abstraction at which automation is explained, or at which it provides explanation, is critical to the establishment and maintenance of trust in it. The third question most often asked by human operators of automation is "What's it going to do next?". This question, like the two above, should also be made unnecessary. As automation becomes more adaptive and intelligent, it will acquire a wider repertoire of behaviours under a wider variety of circumstances. This will make its behaviour more difficult for human operators to understand and predict, even though it may be operating in accordance with its design specifications. It will also be more difficult for human operators to detect when it is not operating properly. Advanced automation must be designed both to be, and to appear to be, predictable to its human operators, and the difference between failure and normal behaviour must be immediately apparent to the human operator.
- **Human-centred automation must be adaptable.** Automation should be configured within a wide range of operator preferences and needs. Adaptability and predictability are, in a sense, opposites, as



highly adaptive behaviour is liable to be difficult to predict. As automation becomes more adaptive and intelligent, it will acquire a wider repertoire of behaviours under a wider variety of circumstances. This will make its behaviour more difficult for the human operator to understand and predict, even though it may be operating in accordance with its design specifications. It will also be more difficult for the human operator to detect when it is not operating normally. This suggests the necessity for constraints on the adaptability of automation to permit the human to monitor the automation and detect either shortcomings or failures in order to compensate for them. "Adaptable", as used here, means capable of being modified according to changing circumstances. This characteristic is incorporated in aircraft automation: pilots need, and are provided with, a range of options for control and management of their aircraft. Similar options should also be available in CNS/ATM system automation. The range of options is necessary to enable the human operators to manage their workload (taking into account differing levels of proficiency) and compensate for fatigue and distractions. In this regard, automation truly acts as an additional member of the control and management team, assisting with or taking over entirely certain functions when instructed to do so. Adaptability increases apparent complexity and is shown here contrasted with predictability, to emphasize that extremely adaptable automation may be relatively unpredictable in certain circumstances. If such a system is not predictable, or if it does not provide the human operator with sufficient indication of its intentions, its apparently capricious behaviour will rapidly erode the trust that the human wishes to place in it. It is good to remember that one of the first principles of human-centred automation states that automation *must* be predictable, if the human is to remain in command.

- **Human-centred automation must be comprehensible.** Technological progress is often equated with increased complexity. Many critical automation functions are now extremely complex, with several layers of redundancy to insure that they are fault-tolerant. It has been noted that training for advanced automated systems is time-consuming and expensive, and that much of the extra time is spent learning about the automation. Simpler models that permit reversion in case of failures should be devised. This will result in training benefits. While automation can be used to make

complex functions appear simpler to the human operator, the consequences of failure modes can appear to be highly unpredictable to that human operator unless the modes are very thoroughly considered in the design phase. Simplicity has not been included as a necessary attribute for human-centred automation, but it could well have been. It is vital that systems either be simple enough to be understood by human operators, or that a simplified construct be available to and usable by them. If a system cannot be made to appear reasonably simple to the human operator, the likelihood that it will be misunderstood and operated incorrectly increases significantly. CNS/ATM systems automation designers and manufacturers should make a considerable effort to make their products simple enough to be comprehended by human operators of widely differing skill levels.

- **Human-centred automation must be flexible.** An appropriate range of control and management options should be available. The term "flexible" is used here to characterize automation that can be adapted to a variety of environmental, operational and human variables. A wide range of automation options must be available to provide flexibility for a wide range of human operators with experience that varies from very little to a great deal and cognitive styles that vary as widely. Given the tendency to an inverse relationship between comprehensibility and flexibility, comprehensibility must not be sacrificed for flexibility, because the ability of the human operators to understand their automation is central to their ability to maintain command.
- **Human-centred automation must be dependable.** Automation should do, dependably, what it is ordered to do, it should never do what it is ordered not to do and it must never make the situation worse. Humans will not use, or will regard with suspicion, any automated system or function that does not behave reliably, or that appears to behave capriciously. This distrust can be so ingrained as to nullify the intended purpose of the designer. Dependability is of a particular importance with respect to alerting and warning systems. Mistrust of legitimate warnings by systems which were prone to false warnings (such as early models of GPWS, MSAW and STCA) have in the past resulted in tragic consequences. In fact, it may be wiser to omit a function entirely, even a strongly desired function, rather than to provide or enable it before it can be certified as reliable.

- Human-centred automation must be informative.** Information is critical both for involvement in the task and for maintaining command over it. If a system were perfectly dependable in operation, there might be no need to inform the human operator of its operation. Perfection is impossible to achieve, however, and the information provided must be as nearly foolproof as possible, bearing in mind that each increase in information quantity makes it more likely that the information may be missed, or even incorrect. One of the first principles of human-centred automation is that “in order to be involved the human *must* be informed.” But, how much information is enough? How much is too much? Human operators want all the information they can get, but they cannot assimilate too much, and what they will leave out is unpredictable. It is desirable to declutter and simplify displays and format changes; in short, to provide for *active* as opposed to *passive* information management, to assist the human operator in assigning priorities to ensure that the most important things are attended to first. Problems may, once again, arise because of automation itself, or simply because the interfaces between the automation and the human are not optimal. The form of information will often determine whether it can be attended to or not and it should be considered during the development of any CNS/ATM information system.
- Human-centred automation must be error-resistant.** Automation must keep human operators from committing errors wherever that is possible. Ideally, the ATM automation system should prevent the occurrence of all errors, both its own and those of the human operators. This may be unrealistic, but a system can and must be designed to be as error-resistant as possible. Resistance to error in automation itself may involve internal testing to determine that the system is operating within its design guidelines. Resistance to human error may involve comparison of human actions with a template of permitted actions, or may be based on clear, uncomplicated displays and simple, intuitive procedures to minimize the likelihood of errors. Automation of unavoidably complex procedures is necessary and entirely appropriate, provided the human is kept in the loop so he or she understands what is going on. The system must be able to be operated by the human if the automation fails, and it must provide an unambiguous indication that it is functioning properly. It is also essential to provide means by which human operators can detect the

fact that human or automation error has occurred. Such warnings must be provided with enough time to permit human operators to isolate the error, and a means must be provided by which to correct the error once it is found. Where this is impossible, the consequences of an action must be queried before the action itself is allowed to proceed.

- Human-centred automation must be error-tolerant.** Some errors will occur, even in a highly error-resistant system; therefore, automation must be able to detect and mitigate the effect of these errors. Since error-resistance is relative rather than absolute, there needs to be a “layered defence” against human errors. Besides building systems to resist errors as much as possible, it is necessary and highly desirable to make systems tolerant of error. In this sense, “tolerance” means the act of allowing something; it covers the entire panoply of means that can be used to ensure that when an error is committed, it will not be allowed to jeopardize safety. The aviation system is already highly tolerant of errors, largely through monitoring by other team members. But certain errors possible with automated equipment, such as data entry errors, may only become obvious long after they have been committed. New monitoring software, displays and devices may be required to trap the more covert errors. In such cases, checks of actions against reasonableness criteria may be appropriate. Given that it is impossible either to prevent or trap all possible human errors, previous aviation occurrences and especially incident data can be extremely useful in pointing out the kinds of errors that occur with some frequency.

3.6.5 The attributes of a human-centred automation suggested above are not mutually exclusive; there is overlap among them. The first principles suggest a rough prioritization where compromise is necessary. It is stated that if humans are to be in command, they must be informed. *Accountability* is an important facet of informing the human operator, as well as an important means by which the operator can monitor the functioning of the automation. *Comprehensibility* is another critical trait if the human is to remain informed; he or she must be able to understand what the automation is doing. Each of these traits is an aspect of *informativeness*. At all times, the human operator must be informed effectively of at least that minimum of information, and informed in such a way that there is a very high probability that the information will be assimilated. In those cases where an automated system acts in an unpredictable manner, an explanation should be readily available if it is not already known or fairly obvious.

3.6.6 With the inevitable exceptions, regulators and the public-at-large agree that humans bear the ultimate responsibility for the safety of the civil aviation system. This suggests that humans must remain in full command of the whole system. However, despite this assertion, it is thought that the independence of automation may tend to bypass the human operator as more and more of the ground elements of the air transportation system are automated. Automation that bypasses the human operators will of necessity diminish their involvement in the aviation system and their ability to command it, which in turn will diminish their ability to recover from failures or compensate for inadequacies in the automated subsystems. Automation designers should conclusively prove that such inadequacies will not exist or such failures will not occur before the aviation community can consider automation systems which can bypass the human operator. It is important that a balance be struck; where compromises are necessary, they must err on the side of keeping the human operator in the loop so that he or she will be there when needed. This point is also made by Billings (1997):

Pilots and air traffic controllers are essential because they are able to make good decisions and take appropriate actions in difficult situations. We have not yet devised a computer that can cope with the variability inherent in the flight and air traffic environment.

3.6.7 Despite spectacular technological advances in automation, the effectiveness of automated and computerized systems remains inextricably linked to the performance capabilities of human operators. ATM automation will force drastic changes in the role of the human operator; it may also cause major changes in the process by which air traffic controllers and pilots work together to accomplish the mission in a most safe manner. If an automated ATM system inhibits the ability of controllers and pilots to work cooperatively to resolve problems, it will severely limit the flexibility of the system, and the loss of that flexibility could undo much of the benefit expected from a more automated system. In this context, advanced automated or computerized systems in the CNS/ATM system should be designed to help humans accomplish new and difficult tasks and safely challenge the needs and requirements of tomorrow. Over time, technology intended to increase safety margins has been used to increase throughput, leaving safety margins relatively unchanged. If humans are to remain fully responsible for system safety, automation should *not* be used to increase system throughput beyond the limits of human capability to operate manually in the event of system automation failure. In developing the various components of the CNS/ATM system, designers and manufacturers as well as regulators should remember

that the most important facet of the whole system is the human who operates, controls or manages the whole system in pursuit of human and social objectives.

3.6.8 Generally speaking, automation evolution to date has been largely technology-driven. However, designers of new aircraft and other aviation systems in recent years have made a determined attempt to help humans do what they may not do well in the press of day-to-day operations. In doing so they have helped to eliminate some causes of human error, while enabling others directly associated with the new technology.

3.6.9 The CNS/ATM system permits more flexible and efficient use of airspace and enhances traffic safety. The air traffic management enhancements include:

- improved handling and transfer of information between operators, aircraft and ATS units;
- improved communications between controllers and pilots by the use of data link technology (CPDLC);
- extended surveillance (automatic dependent surveillance (ADS), etc.); and
- advanced ground-based data processing systems, including systems to display ADS-derived data and aircraft-originated data to the controller allowing for, among other things, improvement in conflict detection and resolution, automated generation and transmission of conflict-free clearances, and rapid adaptation to changing traffic conditions.

3.6.10 The development of the basic aims of the CNS/ATM system including that of advanced aviation systems, together with improved planning, is expected to enhance safety and allow more dynamic use of airspace and air traffic management. In doing so, it is obvious that more automation will be required and utilized. The challenge is to develop a system based on the principles of human-centred automation which takes into account human capabilities and limitations and in summary suggests that:

- **Humans must remain in command of flight and air traffic operations.** Automation can assist by providing a range of management options.
- **Human operators must remain involved.** Automation can assist by providing better and more timely information.
- **Human operators must be better informed.** Automation can assist by providing explanations of its actions and intentions.

- **Human operators must do a better job of anticipating problems.** Automation can assist by monitoring trends, making predictions and providing decision support.
- **Human operators must understand the automation provided to them.** Designers can assist by providing simpler, more intuitive automation.
- **Human operators must manage all of their resources effectively.** Properly designed and used, automation can be their most useful resource.

3.6.11 All concepts presented in this chapter go beyond theory; they can be put to very practical use. The goal is to influence the design of human-machine systems so that human capabilities and limitations are considered from the early stages of the design process and are accounted for in the final design. A design that considers such issues will result in a system that enhances safety, productivity and job satisfaction. The Human Factors profession can provide system designers who possess all the necessary expertise and know-how to incorporate these principles during design.

#### LIST OF REFERENCES

- Bainbridge, L. "Ironies of Automation". In *Analysis, Design, and Evaluation of Man-machine Systems, Proceedings of the IFAC/IFIP/FFORS/IEA Conference*. G. Johannsen and J.E. Rijnsdorp (eds.). Pregamon Press, New York, 1982, pp. 129-135.
- Billings, C.E. "Aviation Automation – The Search for a Human-Centered Approach." Lawrence Erlbaum Associates, Mahwah (NJ), USA, 1997.
- Billings, C.E. "Human-centered Aircraft Automation: A Concept and Guidelines". NASA Technical Memorandum 103885. National Aeronautics and Space Administration, Washington, D.C., 1991.
- Billings, C.E. "Toward a Human-centered Automation Philosophy". Proceedings of the Fifth International Symposium on Aviation Psychology. Columbus, Ohio, 1989.
- Clegg, C., S. Ravden, M. Corbett and G. Johnson. "Allocating Functions in Computer Integrated Manufacturing: A Review and New Method." *Behaviour and Information Technology*, Vol. 8, No. 3, 1989, pp. 175-190.
- Davis, B. "Costly bugs: As Complexity Rises Tiny Flaws in Software Pose a Growing Threat". *Wall Street Journal*. 1987.
- Dekker, S. and Hollnagel, E. "Coping with Computers in the Cockpit". Ashgate Publishing Ltd, Aldershot, Hants, UK, 1999.
- ICAO Annex 11 — *Air Traffic Services* (13th edition), Montreal, 2001,
- ICAO Doc 9583 — *Report of the Tenth Air Navigation Conference*, Montreal, 1991.
- ICAO Doc 9758 — *Human Factors Guidelines for Air Traffic Management Systems*, Montreal, 2000.
- Institute of Electrical and Electronics Engineers (IEEE), "Too Much, Too Soon: Information Overload". *Spectrum*, New York, June 1987, pp. 51-55.
- Isaac, A.R. "Mental Imagery in Air Traffic Control". *The Journal of Air Traffic Control*, Vol. 34, No. 1, 1992, pp. 22-25.
- Lane, N.E. "Evaluating the Cost Effectiveness of Human Factors Engineering". Institute for Defence Analysis Contract MDA 903 '84 C 0031. Essex Corporation. Orlando, Florida, 1987.
- Margulies, F. and H. Zemanek. "Man's Role in Man-machine Systems". In *Analysis, Design, and Evaluation of Man-machine Systems*, Proceedings of the IFAC/IFIP/FFORS/IEA Conference. G. Johannsen and J.E. Rijnsdorp (eds.). Pregamon Press, New York, 1982.
- Orlady, H.W. "Advanced Technology Aircraft Safety Issues". Battelle ASRS Office unpublished report. Mountain View, California, 1989.
- Palmer, E., C.M. Mitchell and T. Govindaraj. "Human-centered Automation in the Cockpit: Some Design Tenets and Related Research Projects". ACM SIGCHI Workshop on Computer-Human Interaction in Aerospace Systems. Washington, D.C., 1990.
- Panel on Human Factors in Air Traffic Control Automation. "The Future of Air Traffic Control: Human Operators and Automation". National Research Council, National Academy Press, Washington, D.C., 1998.
- Patterson, W.P. "The Costs of Complexity". *Industry Week*, 6 June 1988, pp. 63-68.
- Perrow, C. *Normal Accidents: Living with High-risk Technologies*. Basic Books, Inc., New York, 1984.
- Pfeiffer, J. "The Secret of Life at the Limits: Cogs Become Big Wheels". *Smithsonian*, Vol. 27, No. 4, 1989, pp. 38-48.
- Price, H.E. "The Allocation of Functions in Systems". *Human Factors*, Vol. 27, No. 1, 1985.
- Price, H.E. "Conceptual System Design and the Human Role". *MANPRINT*. Harold R. Booher (ed.). Van Nostrand Reinhold, New York, 1990.
- Reason, J. *Human Error*. Cambridge University Press, United Kingdom, 1990.
- Ruitenbergh, B. "Certification of ATC equipment — an oversight in oversight?" Paper presented at the Fifth Australian Aviation Psychology Symposium, Manly, Australia, 2000.

- Schwalm, H.D. and M.G. Samet. "Hypermedia: Are We in for 'Future Shock'?" *Human Factors Bulletin*, Vol. 32, No. 6, 1989.
- Wiener, E.L. "Management of Human Error by Design". Human Error Avoidance Techniques Conference Proceedings. Society of Automative Engineers, Inc., 1988.
- Wiener, E.L. "Human Factors of Advanced Technology ('Glass Cockpit') Transport Aircraft". NASA Contractor Report 177528. National Aeronautics and Space Administration, Washington, D.C., 1989.
- Wiener, E.L. "Fallible Humans and Vulnerable Systems: Lessons Learned from Aviation". *Information Systems: Failure Analysis*. Wise, J.A. and A. Debons (eds.). NATO ASI Series, Vol. F-32, Springer-Verlag, Berlin, 1987.
- Wiener, E.L. and R.E. Curry. "Flight-deck Automation: Promises and Problems". NASA TM 81206. Moffett Field, California, 1980.
- Zuboff, S. "In the Age of the Smart Machine". Basic Books, Inc., New York, 1988.
-

# CHAPTER 4

## ERGONOMICS

### 4.1 INTRODUCTION

4.1.1 Ergonomics has been applied in the design of tools, even in an elementary way, since the beginning of civilization. In aviation, the focus in the early pioneering days — and for many years afterwards — was on advancing some general principles to guide the design of flight deck displays and controls. This later broadened into the experimental analysis of the design and layout of equipment, in close association with the analysis of the demands and workload that the equipment and tasks imposed upon the human operator. Today's approach to design takes the user's characteristics (capabilities, limitations, and needs) into consideration early on in the system development process, and subordinates engineering convenience to them. The terms "user-friendly" and "error tolerant", referring to modern equipment, reflect this intent.

4.1.2 It cannot be denied that technological progress has occurred, nor that such progress has enhanced flight safety, but operational experience indicates that human error is still induced to a significant extent by shortcomings in equipment design or in the procedures used to operate the equipment. Only by taking into account appropriate Human Factors considerations in system design can safety be further enhanced. It would be misleading, however, to propose that safety in the system can be achieved through design improvement alone: as Chapter 2 advocates, a systems approach to aviation safety is required.

4.1.3 This chapter addresses Human Factors issues relative to the interface between humans and machines in aviation. This interface has traditionally been viewed as presenting simple "knobs and dials" solutions to Human Factors problems. In some cases, these solutions could be found by looking at the appropriate table, but an understanding of how to solve Human Factors problems with respect to the human-machine interface within the aviation system is more than learning how to look at tables, especially since such simple solutions may not be valid for all situations.

4.1.4 The purpose of this chapter is to increase the awareness of the pervasiveness and influence of ergo-

nomics in aviation safety. It is intended to provide basic knowledge — as well as a source of information — which will enable the reader to call upon the proper expertise when so required. It also intends to convey, in simple language, the current state-of-the-art information available from States, and to encourage the use of available education and training.

This chapter:

- presents the basic facts about ergonomics, including the difference between ergonomics and Human Factors;
- discusses human capabilities that should be taken into account in equipment design;
- discusses the design of displays and controls, and how they are integrated into the flight deck;
- refers to environmental stresses of relevance to ergonomics.

### 4.2 BASIC FACTS ABOUT ERGONOMICS

#### Introduction

4.2.1 While in many countries the terms *ergonomics* and *Human Factors* are used interchangeably, there is a small difference in emphasis. Human Factors has acquired a wider meaning, including aspects of human performance and system interfaces which are not generally considered in the mainstream of ergonomics. Chapter 1 proposes that the two terms be considered synonymous, to preclude dwelling on academic or semantic considerations and to avoid confusion; however, it indicates that the term *ergonomics* is used in many States to refer strictly to the study of human-machine system design issues. From this perspective, ergonomics is the study of the principles of interaction between human and equipment, for the purpose of applying them in design and operations. Ergonomics

studies human attributes, determining what requirements in hardware and software result from the characteristics of the activities involved. It attempts to solve the problem of adapting technology and working conditions to humans. Throughout this chapter, this latter concept of ergonomics has been adopted, and as such, it is clearly differentiated from Human Factors.

#### A systems approach to safety

4.2.2 Safety in aviation through design can best be achieved following a system approach strategy. A system approach is a way of breaking down the "real world" into identifiable components, and looking at how these components interact and integrate. The Liveware-Hardware interface in the SHEL model, introduced in Chapter 1, can be seen as a *human-machine system*, comprising people and machines interacting in an environment in order to achieve a set of system goals. Ergonomics will try to optimize the interaction between people and machines in

the system (the L-H interface), while taking into consideration the characteristics of all system components (e.g. the environment as well as the software).

4.2.3 A simplified representation of the person-machine system is shown in Figure 4-1. The *machine component* is displayed on the right. Displays (e.g. visual and auditory) inform the human about the status of the internal system or about conditions external to the system, while controls allow the human to effect changes in the system status. The *human component* of the system is shown on the left side of Figure 4-1. Information displayed must be perceived and processed by the human, and then conscious decisions may be made. Motor responses may be sent to effect changes in control settings. The line depicted in Figure 4-1 separating the machine and human represents the *human-machine interface*. Information travels through this interface in both directions; ergonomics is very much concerned with getting the information across this interface, and the ergonomist must ensure that displays and controls are compatible with human capabilities and task needs.

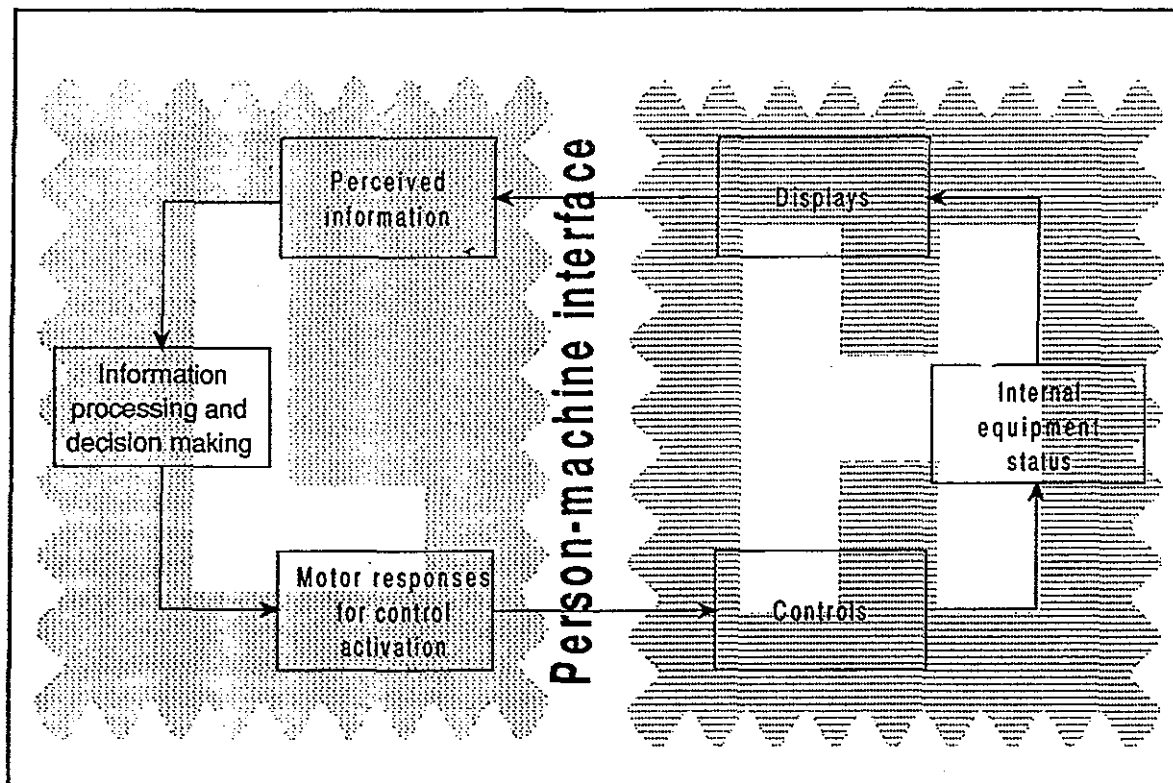

Figure 4-1. Representation of a person-system machine  
(adapted from Meister, 1979)

4.2.4 System goals must be defined before a person-machine system can be specified and designed. These goals, together with the identified operational constraints, spell out the conditions within which the person-machine system will function. Operation of the system outside this set of conditions may lead to unsafe conditions.

4.2.5 Another important task of the ergonomist is the allocation of functions and tasks to the human and machine components. The system design team (including the ergonomist) decides what functions should be given to the hardware and software and to the human, based on considerations such as human characteristics, task needs, workload, costs, training requirements, and technologies available. Functions allocated inappropriately may jeopardize system effectiveness and safety. The tendency to compare human and machine, in terms of the functions for which humans are superior to machines vis-à-vis those for which machines are superior to humans, should not be allowed to lead to a simplistic allocation of functions entirely to the human or the machine. Humans and machines should be *complementary* in the accomplishment of tasks. Furthermore, this complementarity should be designed with adequate flexibility so that function allocation can be adapted to various operational situations (from routine flight to emergencies).

4.2.6 The ergonomist must proceed systematically in order to achieve the desired system goals. The following set of example questions illustrates how an ergonomist may proceed when designing systems:

- What inputs and outputs must be provided to satisfy systems goals?
- What operations are required to produce system outputs?
- What functions should the person perform in the system?
- What are the training and skills requirements for the human operators?
- Are the tasks demanded by the system compatible with human capabilities?
- What equipment interfaces does the human need to perform the job?

A system designed without proper regard to these questions may end up like the one shown in Figure 4-2.

#### Control of human error

4.2.7 Human error is a very complex issue. This term must be used judiciously, as it may be perceived as

a loaded term implying blame. Moreover, the word "error" implies deviation from a definable correct or appropriate behaviour. In fact, appropriate behaviour is often difficult to define, and human error is increasingly being postulated as a symptom of deficiencies in equipment design or system performance rather than a cause in itself. Despite these cautions, human error continues to be an important concept in understanding the nature of and the factors affecting human behaviour, and various classifications of human errors have been proposed by different authors.

4.2.8 To minimize human error, one must first understand its nature. There are basic concepts associated with the nature of human error: *the origins and frequencies of errors can be fundamentally different; and the consequences of errors can also be significantly different.* While some errors may be due to carelessness, negligence or poor judgement, many are induced by poorly designed equipment or may result from the normal reaction of a person to a stressful situation. Errors due to poor equipment design or stressful situations are likely to be repeated and can be remedied through the practice of ergonomics.

4.2.9 Each of the interfaces in the SHEL model has a potential for error where there is a mismatch between its components. For example:

- The *Liveware-Hardware interface* is a frequent source of error: knobs and levers which are poorly located or improperly coded create mismatches at this interface.
- In the *Liveware-Software interface*, delays and errors may occur while seeking vital information from confusing, misleading or excessively cluttered documentation and charts. Problems can also be related to information presentation and computer software design.
- Errors associated with the *Liveware-Environment interface* are caused by environmental factors such as noise, heat, lighting, air quality and vibration and by the disturbance of biological rhythms.
- In the *Liveware-Liveware interface*, the focus is on the interaction between people because this process may affect crew and system effectiveness. This interaction also includes leadership and command, shortcomings in which may reduce operational efficiency and cause misunderstanding and errors.

Considerations which prevent errors such as these are in the mainstream of ergonomics.



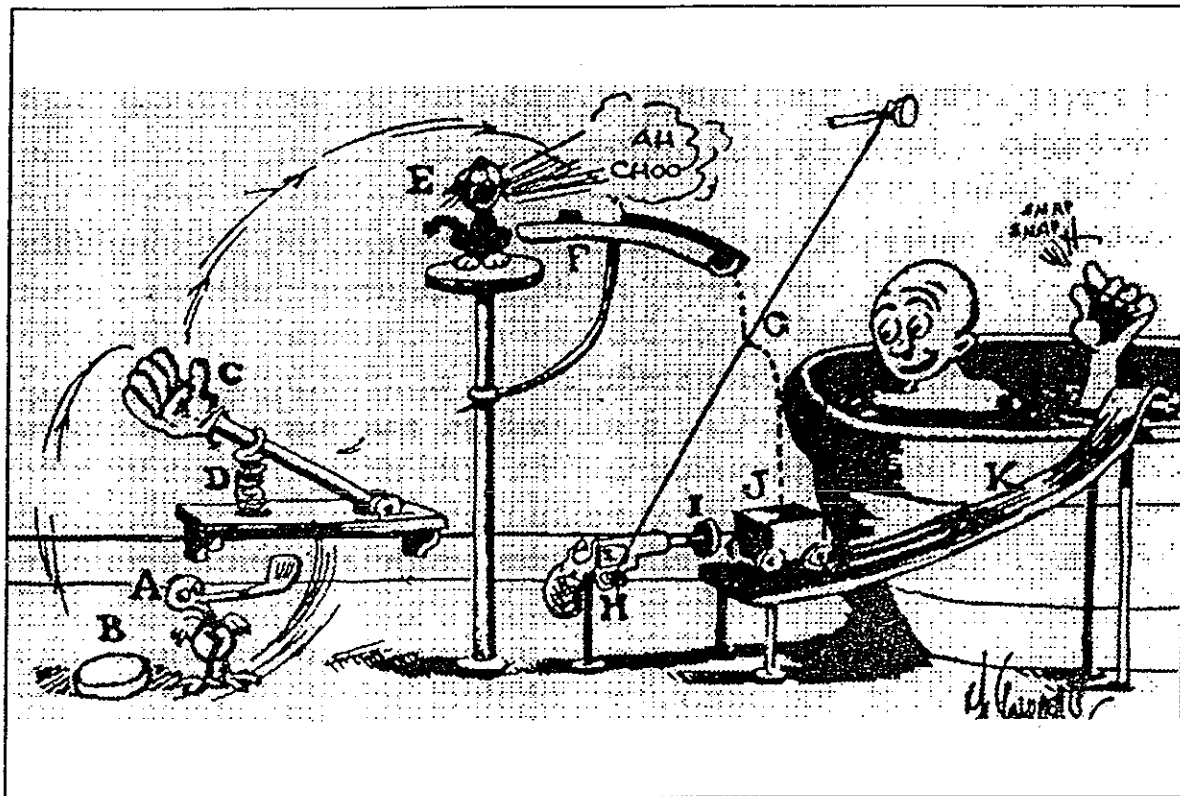

Figure 4-2. If the soap falls out of the bathtub, try this!  
(adapted from *The Best of Rube Goldberg*, compiled by Charles Keller, Prentice-Hall, 1979)

4.2.10 The control of human error requires two different approaches. First, it is desirable to *minimize the occurrence of errors* (total elimination of human error is not a realistic goal, since errors are a normal part of human behaviour). For example, errors may be reduced by ensuring a high level of staff competence; by designing controls and displays so that they match human characteristics; by providing proper checklists, procedures, manuals, maps and charts; by controlling noise, vibration, temperature extremes and other stressful conditions; and by providing training and awareness programmes aimed at increasing co-operation and communication among crew members. The second approach in the control of human error involves *minimizing the impact or consequences of errors* by providing safety buffers such as cross-monitoring, crew co-operation and fail-safe equipment design.

### 4.3 HUMAN CAPABILITIES

#### The visual system

4.3.1 The visual system (i.e. the eyes and the associated parts of the nervous system) is generally

considered to be the most important sensory system by which humans acquire information from external sources. No attempt will be made to discuss the anatomy of the visual system, since it is described in many standard texts. The emphasis is to highlight the visual system at work, what it does and does not do. Visual performance depends on several factors: some are internal to the visual system (i.e. visual acuity, accommodation and convergence, adaptation to light and darkness, perception of colours, etc.), while others are external and include variables such as task, target, and environmental characteristics (e.g. light intensity, contrast, size, location, movement and colour). All of these factors interact to determine the accuracy and speed of human visual performance. An understanding of these human and system factors will enable the ergonomist to predict and optimize system performance in a variety of operational conditions.

4.3.2 It is convenient to separate visual functions into its three component senses: light, form, and colour. The eye is capable of functioning over a wide range of light intensities, from faint starlight over full moon to bright sunshine. The eye requires time to adjust to varying levels of light intensity because the mechanism involved is a photochemical process. When adapting from dark to

light the eye adjusts rapidly, whereas in adapting from light to dark the adjustment is slow. The adaptation involves three processes. First, the amount of light that can enter the eye (and thus reach the retina) is regulated by pupil size; pupil size increases when a person tries to see in the dark and decreases while in brighter light. Secondly, a photochemical process occurs when light intensity changes. Thirdly, two mechanisms function at different light intensity levels: rod vision, based on the function of the peripheral light receptors in the retina, the rods, operates from the threshold up to moonlight level; here form acuity is poor and colours cannot be discriminated. From early morning light level, cone vision, based on the function of the central light receptors in the retina, the cones, takes over and form acuity and colour perception become good. At the transitional stage, roughly corresponding to full moonlight, both rods and cones are functioning. Another important feature of rod and cone vision is their different spectral sensitivity, easily detected at dusk when red colours turn dark before other colours change, due to the relative insensitivity of the rods to red light. A result of this double mechanism for light appreciation is that, to detect dim lights, one must look off-centre. To endeavour to protect night vision by preserving rod adaptation (red cockpit lighting) is to a large extent illusory as very few flight tasks can be performed with rod vision.

In November 1979, a DC-10 on a sightseeing flight over the Antarctic crashed into the side of a 12 000 ft volcano. The aircraft had descended below the overcast at 6 000 ft to provide the passengers with a view of the ice pack below. Incorrect navigation coordinates loaded into the Inertial Navigation System (INS) put the aircraft 25 miles off the correct track; however, the crew failed to spot the slopes of the volcano in a condition with 70 km visibility. Close examination of the effects of visible and invisible texture on visual perception, and the illusion caused by sector whiteout can offer an explanation regarding why the crew did not see the obstacle.

Source: ICAO ADREP Summary 80/1.

4.3.3 Visual acuity is the ability of the visual system to resolve detail. It can be expressed in various notations, commonly, it is expressed in terms related to the smallest letter an individual can read from a Snellen chart at 20 feet compared with the distance at which a "normal" person can read the same letter. For example, 20/20 is

normal vision, and 20/40 means that the individual can read at only 20 feet what a normal person would read at 40 feet. Absolute brightness, brightness contrast, time to view the object, movement and glare are among the factors which affect visual acuity.

4.3.4 To see an object sharply, the eye must focus on it. When focusing on objects between infinity and 5-6 metres, the normal eye does not change, but when focusing on objects at a shorter distance (less than c. 5 metres), two things happen: the eyes accommodate (i.e. they adjust their refractive state to correspond to the distance to the object), and the eyeballs turn inwards so that the visual axes of the two eyes converge on the object. When visual clues are weak or absent (e.g. empty space), the muscles controlling accommodation and convergence adjust by themselves to a distance of c. one metre ("empty space myopia"). This will significantly affect visual performance when a person is looking for distant objects and visual cues are weak, as is the case when trying to spot reported traffic from a flight deck.

4.3.5 Spatial orientation involves both the visual function and the vestibular apparatus ("balance organ") of the inner ear. Proprioception ("seat of the pants") plays a role too, but it is less important. It is also influenced by past experience. Figure 4-3 presents a simplified model of this activity.

In June 1988, an Airbus A320 crashed in Mulhouse-Habsheim, France, during a flight. The report of the Investigation Commission includes the following remarks on the subject of visual misjudgment: "Whereas he [the captain] was accustomed to using 2 000- to 3 000-m long runways with approximately 100-ft high control towers, he found himself on an 800-m long grass strip with a 40-ft high tower; the scale effect may have created a false impression." The report also mentions that the very high nose-up attitude, given the approaching maximum angle-of-attack, would have put the pilot's eye-level particularly high compared with the rest of the airplane. The first tree impact involved the rear fuselage.

Source: ICAO ADREP Summary 88/3.

4.3.6 The eye usually conveys the information sensed fairly faithfully. Ambiguity and uncertainty may occur, however, when this sensed information is processed

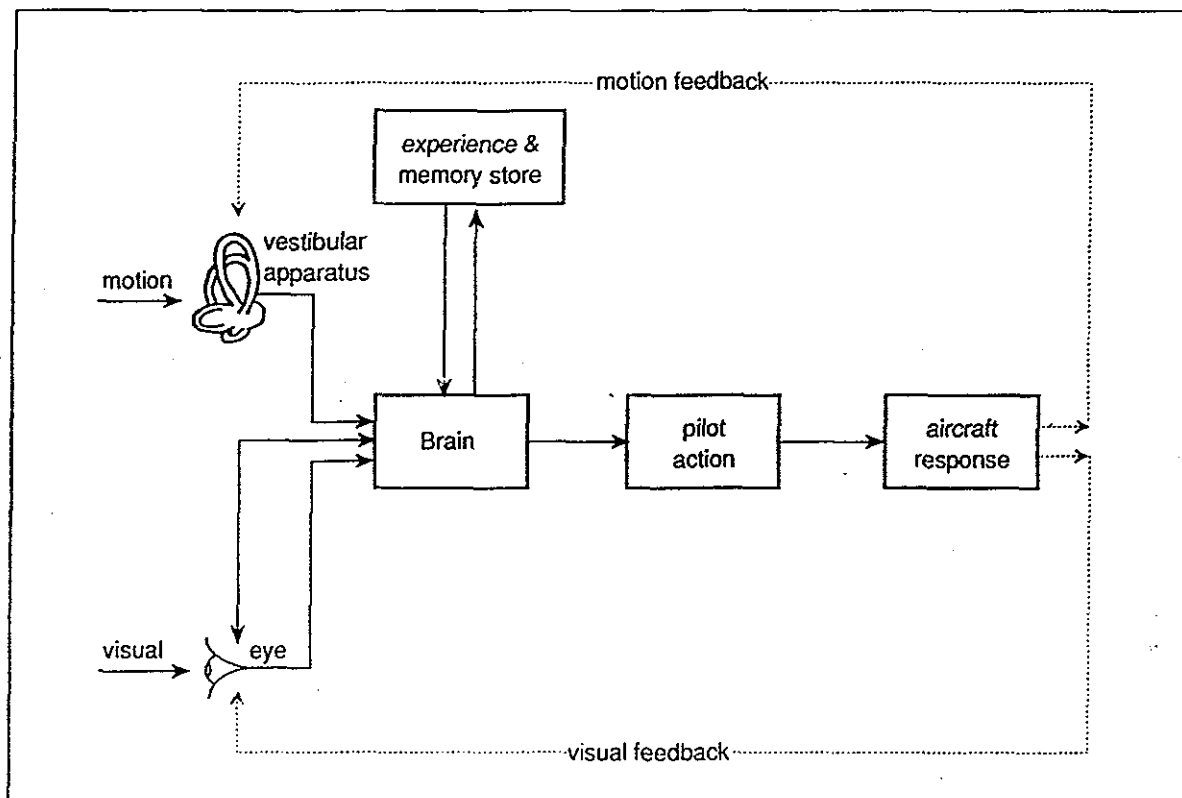

Figure 4-3. A simplified model illustrating some of the components involved in visual perception (adapted from Hawkins, 1987)

by the brain and combined with emotional factors, past learning, experience or expectation. These factors are included in the mind set, which is well reflected in the popular saying that one sees what one expects to see. For example, a warning light indicating system failure may be correctly sensed, but a pilot's past experience with nuisance warnings may suggest that the warning is based on a faulty signal and can therefore be ignored.

4.3.7 *The failure to respond to a visual stimulus even when clearly perceived may be due to fascination (i.e. conning of attention). In such a case, the pilot concentrates on one flight instrument — for example, the flight director — and disregards other important information to which the pilot should respond. Fascination occurs not only under conditions of high workload, but also when workload is low and tedium prevails.*

A de Havilland DHC6-300 Twin Otter, hauling a diamond drill and crew, was approaching to land onto a 700-ft long esker (an esker is a geological formation like a sand bar) near Concession Lake, Yellowknife, Canada. The aircraft touched down in a ravine, 65 ft short. The pilot had never landed in this particular esker before and he did not notice an 8-degree upslope, resulting in a flat approach.

Source: ICAO ADREP Summary 89/381.

4.3.8 *Visual illusions* of one kind or another have been experienced by all flight deck crew members. For many years physiologists and psychologists have been proposing theories to explain them, and such studies and general information on visual illusions in aviation can be found elsewhere. For the purpose of this chapter, it is enough to emphasize human vulnerability to these phenomena.

A Cessna Citation was descending from FL330 for a visual night landing at Stormoway, UK, in December 1983. The aircraft was observed on the radar display continuing a steady descent to sea level, where the radar trace disappeared, 10 mi from its destination. The night was very dark, and there was a layer of stratus clouds between 1 000 and 3 000 ft. Radar recordings indicate that at about 3 000 ft, the pilot reduced to approach speed, lowered the flaps and gear and descended very rapidly. All occupants died of drowning, indicating a non-violent impact with the sea. No evidence was found from the partially recovered wreckage indicating engine or airframe failure. The approach over the dark sea towards a lighted area fostered conditions conducive to visual illusions.

Source: ICAO ADREP Summary 85/1.

#### The vocal and auditory systems

4.3.9 The *vocal system* generates speech, which is the result of the interaction of several of its components. Different voices utilize different ranges of pitch and frequency, and although there are many ways in which speech can be deformed, so long as the pattern of frequency remains intact, the speech will remain intelligible. The *auditory system* senses audio signals and speech, and conveys them to the brain for processing. The external ear comprises the pinna, auditory canal, and eardrum. The middle ear has three small bones called ossicles, which transmit sound from the outside to the inner ear. The middle ear is connected to the nose and throat; through swallowing, yawning or sneezing, pressure within the middle ear is equalized with that of the outside. The inner ear houses the vestibular apparatus which has functions such as maintaining balance and providing the brain with information related to acceleration and changes of position.

4.3.10 Impaired hearing may be a result of the connection between the middle ear and the mouth/nose being blocked (e.g. due to a common cold). It may also be caused by the deposit of new bone or calcium material in the ossicles or by infections in the middle ear causing accumulation of fluid which dampens the movement of sound-transmitting components. Long-term exposure to loud noise (such as that from machinery or aircraft engines) may damage permanently nerves in the inner ear. Disease conditions such as brain tumours and strokes can interfere with the functioning of the brain region which is associated with hearing. Lastly, hearing ability generally deteriorates with age.

4.3.11 There are four primary characteristics of sound in speech: *intensity* (sound pressure level), which is measured in decibels (dB) and results in the subjective sensation of loudness; *frequency*, which is measured in hertz (Hz) or cycles per second and produces the sensation of pitch; *harmonic composition*, which refers to the quality of speech; and the *time factor*, which reflects the speed at which words are spoken, the length of the pauses, and the time spent on different sounds.

"On arrival to work I climb into a helicopter (worth about three million pounds) and am subjected to appalling noise levels — even allowing for the use of a good headset AND earplugs, very aggravating levels of vibration, an excruciatingly uncomfortable seat, a cockpit heater that works flat out or not at all — etc., etc. The list goes on and on. Why has the situation been allowed to come about? How can this situation be resolved? ..."

Source: CHIRP Feedback No. 10, April 1986 [Feedback is the periodic bulletin of the United Kingdom CAA Confidential Human Factors Incident Report (CHIRP)].

4.3.12 *Noise* is any unwanted sound or sound which has no relationship with the immediate task. It may interfere with speech communications, annoy the listener or affect task performance, and it may have health implications. The relationship between the loudness of the "wanted" sound and that of the background noise is called *signal-to-noise ratio*, which is more important factor than the absolute level of the signal or noise when determining intelligibility. Noise as an environmental stressor is further discussed later in this chapter.

... Towards the end of this transmission (the ATC clearance), the CVR showed that the captain made the exclamation "Yes!". Some five seconds later, while the first officer was still reading back the ATC clearance, the captain said, "We go — check thrust ..." followed by the sounds of engine spin-up.

The CVR showed that the last portion of the first officer's readback became noticeably hurried and less clear. He ended his readback with the words, "We are now — uh — takin' off" or "We are now at take-off".

The controller then said, "Okay (pause) stand by for takeoff, I will call you". On the KLM CVR, the portion of this transmission following the word "okay" was overlaid by a high-pitched squeal, and the tone of the controller's voice was somewhat distorted, though understandable.

In Clipper 1736, upon hearing the KLM first officer advised that they were "taking off", and the controller's "okay" and pause, the Pan Am first officer transmitted: "and we are still taxiing down the runway — the Clipper one seven three six". It was this transmission which caused the squeal and the distortion in the KLM cockpit of the controller's transmission directing them to stand by for takeoff. The Pan Am transmission was itself totally blocked by the controller's transmission to KLM. Only the words "Clipper one seven three six" were heard in the tower. The controller then said, "Papa Alpha one seven three six, report runway clear", to which the Clipper replied, "Okay, we'll report when we are clear". During these transmissions, KLM 4805 continued to accelerate on its takeoff run.

Aboard the KLM aircraft, the flight engineer asked, "Is he not clear, then?" The captain said, "What did you say?" The flight engineer: "Is he not clear, that Pan American?" To this, both captain and first officer responded with a positive and almost simultaneous, "Yes".

About seven seconds later, the first officer called, "V one". Three seconds later, the Dutch crew saw directly in front of them the shape of Clipper 1736 turning to KLM's right in its attempt to clear the runway. At 1706:49 GMT, KLM 4805 collided with Clipper 1736.

Source: "Human Factors Report on the Tenerife Accident" U.S. ALPA.

4.3.13 *Redundancy* in spoken language helps to convey information even when the sound is distorted or surrounded by noise. One underlying danger in the case of distorted information is that gaps are filled in by the listener based on previous experience, learning and expectation, hence there is a risk of false hypothesis emerging. *Masking* is the consequence of one sound component (e.g. unwanted noise) reducing the ear's sensitivity to another component (e.g. an audio signal or speech). The more the speech content is lost — through distortion, noise, personal hearing deficiencies, etc. — the greater the risk of expectation playing a role in the interpretation of aural messages. The consequence of this may be disastrous.

4.3.14 Ergonomics attempts to mitigate the adverse effects of noise on hearing and speech intelligibility by attacking the problem at the source, transmission, and/or receiver end of the signal, speech, or noise.

## 4.4 HUMAN INFORMATION PROCESSING

4.4.1 Humans have a powerful and extensive system for sensing and processing information about the world around them. The information sensing and processing can be broken down into several stages as generalized in Figure 4-4. Information in the form of stimuli must be sensed before a person can react to them. There exists a potential for error, because the sensory systems function only within a narrow range. Once stimuli are sensed, they are conveyed to and processed by the brain. A conclusion is drawn about the nature and meaning of the message received. This interpretative activity involving high-level brain functions is called *perception*, and is a breeding ground for errors. Expectation, experience, attitude, motivation, and arousal all influence perception and may cause errors.

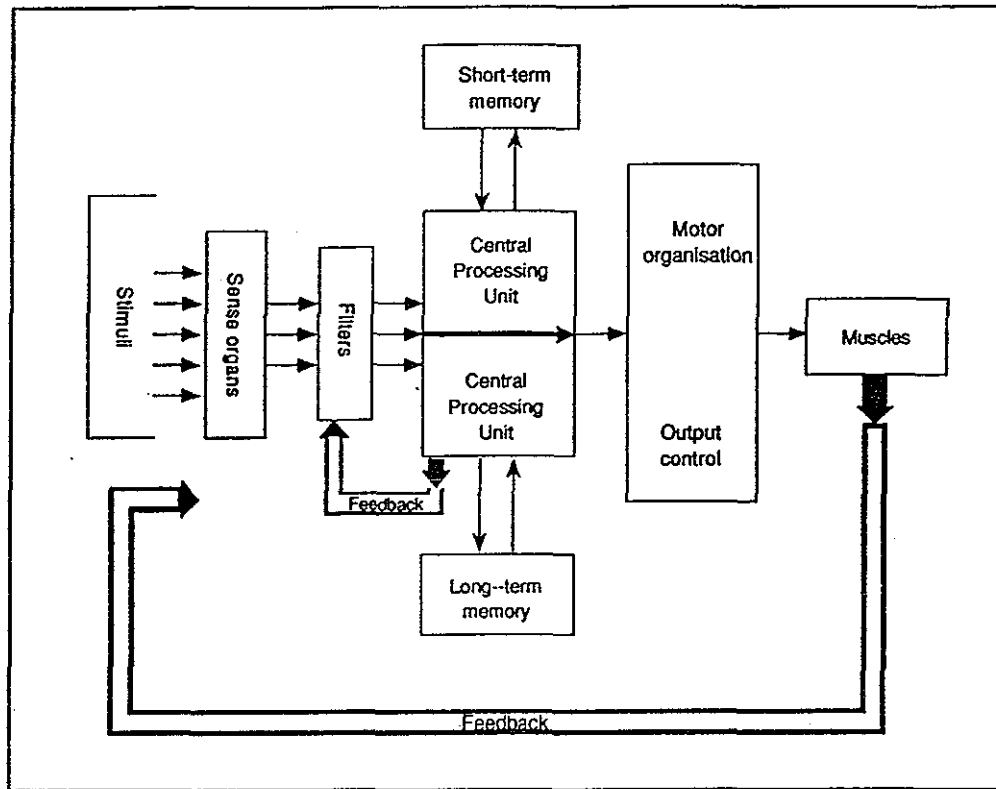

Figure 4-4. Model of the human information processing system  
(adapted from Hawkins, 1987)

4.4.2 After conclusions have been formed about the meaning of stimuli, decision-making begins. Again, many factors may lead to erroneous decisions: inadequate/inappropriate training or past experience; emotional or commercial considerations; fatigue, medication, motivation and physical or psychological conditions. Action (or inaction) follows decision. Once action has been taken, a feedback mechanism may be available to inform the person how effective the action was. Potential for committing errors exist in these two last phases.

4.4.3 The ability to remember is essential to human information processing; even the simplest system cannot function without memory. Since human memory is a limited resource, the ergonomist must be careful to design systems that do not overload it. There is a distinction between long- and short-term memory. Long-term memory is associated with the retention and retrieval of information over a long period of time. Instruction and training are effective means of enhancing those retention and retrieval capabilities. Short-term memory allows data retention and processing for current activities. The data readily fade away after the activities are completed.

4.4.4 The duration of information storage differentiates short-term from long-term memory. Short-term memory involves rapid, continuous changes in information, and allows short-term retention and processing of data. Long-term memory involves less frequently repeated sequences and is characterized by long-term storage of information. Repetition or rehearsal allows information to be stored in long-term memory.

4.4.5 Short-term memory has very limited capacity. It has generally been determined that it can accommodate a small amount of information at one time (seven plus or minus two elements). Elements (e.g. symbols) at the beginning and, especially, at the end of a series are retained better. Human ability to discriminate visual information is similarly limited. This fact should be considered when presenting information on the flight deck.

4.4.6 The above-mentioned limitation of seven data elements holds for items which, in the person's experience, appear unrelated. For example, the term LOW PRESSURE involves 11 unrelated letters, but they are really two groups or chunks for short-term memory. The

individual items within each chunk have been blended as a single coherent unit. In any system in which strings of items need to be memorized, the ergonomist must try to capitalize on the chunking principle to enhance short-term memory.

"Approaching from the west. Approach instructed "Report visual before joining. Expect clearance to joining downwind left-hand for Runway 31, QFE ...

"Reported visual and told to call Tower. Tower instructed us to "Join downwind left-hand for runway 13, QFE ...". The other pilot and I both wrote this down independently, and read it back. In view of the previous message I wondered whether to query it, but this ATC is usually pretty good, so I decided I must have mis-heard the previous.

"... Just about airport boundary we saw an aircraft on short finals for 31 ... Tower called back rather irately "You were cleared to join downwind left-hand for 31 ..."

"... Another classic human error which has always existed with 13/31 runways since the advent of radio control. Transpositions or swaps of positions are one of the commonest types of error in short-term memory ..."

Source: CHIRP Feedback No. 23, February 1991.

**4.4.7 Attention**, as a technical term, has two different meanings. It refers to the human ability to ignore extraneous events and to focus on the events of interest (selective attention). This is exemplified by a person's ability to maintain a conversation amid a noisy party. It is, in short, the ability to focus on a source of information embedded within several sources. On the other hand, divided attention is the human capability to attend to more than one thing at the same time. An example of this is talking to ATC and watching for outside traffic simultaneously.

**4.4.8** There is no single definition for mental workload. Some relate it to information processing and attention, others to time available to perform a task, still others to stress and arousal. Subjective opinions on workload can be collected, using rating scales, questionnaires or interviews; these methods have been frequently used when

attempting to define or measure workload under operational conditions. As technology advances in our society, mental workload will become more important than physical workload. With modern automated systems, operators sometimes have monotonous work which consists of unvarying physical or mental activity. Considerable effort has been directed, and will continue to be directed, to establishing methods for assessing mental workload, with the ultimate goal of describing or predicting how much mental workload is associated with a given task.

In May 1978, a Boeing 727 crashed into Escambia Bay while on a surveillance-radar approach to Pensacola Regional Airport. The crew was blamed for the unprofessional way in which they conducted the non-precision approach. However, ATC was also mentioned as a factor which accelerated the pace of flight deck activities after the final approach fix. NTSB found that the aircraft was positioned on the final approach course "... in a situation that would make it impossible for the captain to configure his aircraft in the manner specified in the flight manual". There was also confusion regarding the nature of the instrument approach available at Pensacola. These factors resulted in the crew's failure to extend the gear and flaps appropriately. Moreover, subsequent warning from the ground proximity warning system went unheeded, and it was turned off seconds before the impact. The NTSB concluded, "... these [events] increased the captain's workload, and contributed to producing the major causal area of the accident - a lack of altitude awareness".

Source: ICAO ADREP Summary 78/6.

## 4.5 HUMAN DIMENSIONS

**4.5.1** One of the primary objectives of ergonomics is to match working (and living) areas and stations with human characteristics. Some of the basic characteristics of humans are those associated with the size and shape of the various parts of the body and with their movements. Figure 4-5 illustrates the importance of considering human dimensions in equipment design. The controls of some lathes in current use are so placed that the ideal operator should be four-and-a-half feet tall, be two feet across the shoulders, and have a four-foot arm span — it is probably easier to change the machine than the people who must operate it! Anthropometry is concerned with human

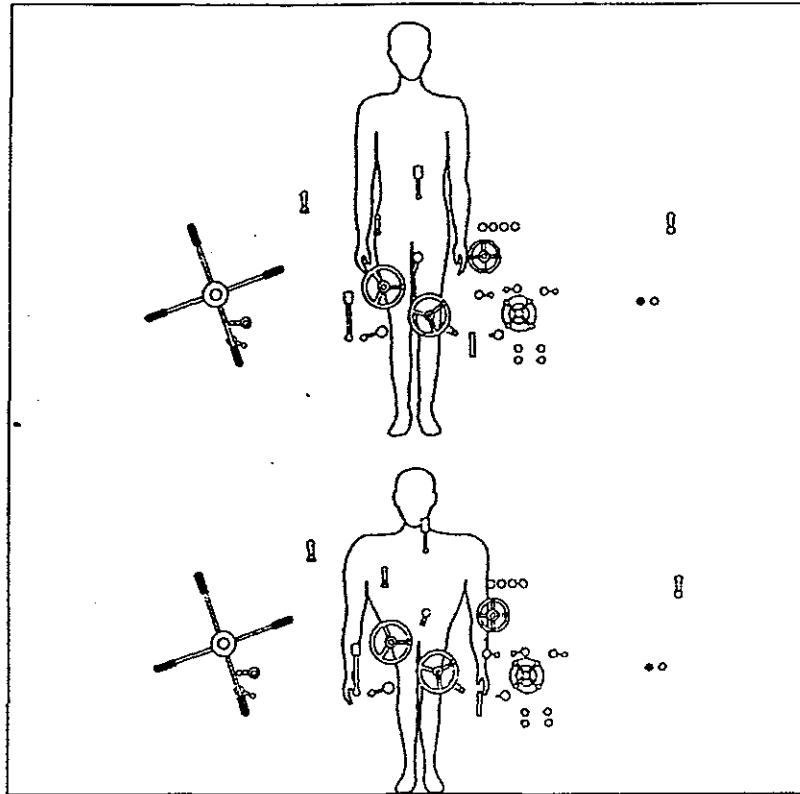

**Figure 4-5. The controls of a lathe in current use are not within easy reach of the “average” person**  
(from *Applied Ergonomics IPC*; 1969; Vol. 1)

dimensions such as weight, stature, limb size and other specific measures such as seated eye height and reach when seated with and without restraining devices (such as a shoulder harness). With this information it is possible to estimate the optimum height for work surface and location of controls, the height and depth of stowage areas, minimum knee room between seat rows, width of seats, length of armrests, height of headrest, life-raft and seat cushion design, and reach requirements. Biomechanics specializes in the application of the science of mechanics in the study of living organisms (the human being in this case). The discipline studies areas such as the movements of body parts and the forces they can apply. For example, it is necessary not only to know that a certain force will move a control, but also where the control is located relative to the body and the direction of control movement.

4.5.2 Data collection is an important step. Data must be collected from a representative and sufficiently large sample of the people who will use the equipment. When using these data, one must take into account the date of data collection, since human physical dimensions may

change from generation to generation. For example, it is known that people in some developed countries have generally become taller during the past 50 years. An ergonomist must determine when and how such changes will become a factor in design considerations.

4.5.3 The ergonomist should take into account the concept of designing for human differences. Not only are there differences in physical dimensions among ethnic groups, but there are also differences between men and women within one ethnic group (for instance, control force requirements which can be met by males may be too high for females). Many aviation hardware pieces have for some time been manufactured according to Caucasian male dimensions, even though in many cases they are equally used by Asians, Africans, and others. The ergonomist will identify the target user group and design equipment accordingly. If a single design solution to accommodate all user differences is not possible, a range of adjustments is provided, so that most users are accommodated — rudder pedal and seat adjustments on the flight deck are among the examples.



## 4.6 DISPLAYS, CONTROLS AND FLIGHT DECK DESIGN

4.6.1 Displays and controls are at the heart of ergonomics. If we refer to the SHEL model, they are mostly part of the Liveware-Hardware and Liveware-Software interfaces. In the case of displays, the transfer of information goes from the Equipment to the Liveware. Controls are used to transfer information and commands in the other direction, from the Liveware to the Equipment. There is usually an information loop involved in this process, and ergonomists have the mission of optimizing the flow within this loop. The following paragraphs present some of the considerations in the design of displays and controls and their integration into the workplace of the flight deck.

4.6.2 This chapter does not discuss the issues associated with the introduction of automation on the flight deck. Part 2, Chapter 4 addresses this important and contemporary aspect of flight deck design.

### Displays

4.6.3 The function of a display is to convey information (about the status of the flight for example) accurately and rapidly from its source to the operator. Human capabilities and limitations in information processing discussed before should be considered in the design of displays. Timely, appropriate, accurate, and adequate amount of information must be presented to the operator according to task requirements. It would be detrimental to task performance to present more information than required, especially when the operator is overloaded, fatigued or under stress.

4.6.4 Visual displays may be *dynamic* (e.g. altimeters and attitude indicators) or *static* (e.g. placards, signs, and charts) They present quantitative (e.g. altitude and heading) or qualitative (e.g. landing gear status) information. They may warn (e.g. ENGINE FIRE) or caution (e.g. oil pressure indicator or light).

4.6.5 Displays may also be *tactile/kinaesthetic* (tactile means related to the sense of touch, kinaesthetic related to the sense of motion) or *auditory*. Especially when the visual system is (or is expected to be) heavily loaded, these displays may be used to communicate information to the human operator. Tactile/kinaesthetic information transfer may also be applied under degraded visual conditions. (A stall warning using the stick-shaker method is a good example). The auditory canal is particularly suited for alerts such as warnings. For this reason, there is a tendency to apply such aural displays heavily, sometimes indiscriminately, on the flight deck. Indiscriminate

use of aural alerts on the flight deck has been known to cause annoyance and confusion or to affect task performance negatively. In such cases, one cannot over-emphasize the importance of taking proper Human Factors considerations into account in the design of these displays.

4.6.6 There are basic issues which must be resolved before a display can be properly designed and located. Both design and location of displays can greatly influence the effectiveness of the dialogue between human and machine. The following are some example considerations:

The drum-pointer altimeter display has a history of being misread in studies and real-life occurrences dating back to 1959. This particular instrument is susceptible to the thousand-foot misreads, especially when the indication is near zero. The results of a study undertaken by NASA indicated that the problem is because humans cannot efficiently read both the drum and pointer at the same time. They also showed that the number of times when the altitude window on the drum-pointer altimeter is read is very small. The time necessary to read the window is almost twice as long as text reading. This instrument is believed to have been misread, and considered a contributing factor, in at least the following accidents:

- a. American Airlines B727, Constance, Kentucky (USA), November 1965;
- b. Northeast Airlines DC9, Martha's Vineyard, Massachusetts (USA), June 1971;
- c. Eastern Airlines DC9, Charlotte, North Carolina (USA), September 1974;
- d. National Airlines B727, Pensacola, Florida (USA), May 1978;
- e. Alitalia DC9, Palermo, Italy, December 1978; and
- f. Iberia B727, Bilbao, Spain, February 1985.

Source: "The Killer Instrument — The Drum Pointer Altimeter" (1990) Harold F. Marthinsen, Director of US ALPA's Accident Investigation Department.

- How, by whom, and in what circumstances will the display be used?
- Auditory displays are generally omnidirectional, while visual displays are not. Will more than one person be required to see the display?

- How will ambient illumination influence the effectiveness of the visual display?
- Should the information be presented in the analogue or digital format? Digital displays provide greater accuracy for recording or systems monitoring (e.g. for engine instruments), while analogue instruments are preferable when the numeric values are changing frequently or rapidly (e.g. with altimeter and rate of climb indicators).
- What is the angle at which the display will be viewed?
- Will there be parallax problems?
- What will be the viewing distance? Will character and symbol sizes need to be increased to afford readability at a distance?
- Displays which are in a standby or inactive mode should clearly enunciate that fact. Ambiguity will likely increase mental workload and induce errors.
- Information which is suspect should not continue to be displayed to the operator.
- Consider display factors such as brightness, colour, contrast and flicker.

4.6.7 The display of letters and numbers (known as alphanumeric) has been the subject of much research. Mechanical, electro-mechanical and electronic displays present various ergonomic problems which deserve attention. Information presented must be legible, so that characters can be easily differentiated or identifiable. In addition, the information must be readable, which means that total words or groups of letters and numerals are comprehensible. Readability is generally a function of factors such as character style, type form (e.g. uppercase or italics), size, contrast and spacing.

4.6.8 Dial markings and shapes are two additional aspects considered by the ergonomist. Examples of the basic types of displays used in presenting quantitative information are shown in Figure 4-6. Scale progressions should have fixed and regular graduation markings, and should be presented in single units. Steps of 10 or 5 are good, and steps of 2 are acceptable. Decimal points should be avoided, and if used, the 0 ahead of the decimal point should not be included. Full readings should be displayed as opposed to truncated versions (e.g. 15 for 150). Care should be taken in the design of pointers when the instrument also contains a digital read-out which can be

Shortly after a night takeoff from Bombay, at an altitude just under 1500 ft, the Boeing 747 with 210 persons on board rolled a 14-degree bank to the right. Over the next 13 seconds, the aircraft gradually returned to wings-level. Then it continued to roll into a 9-degree left bank. At this point, an abrupt left-aileron input was made, it was momentarily reversed, and then went to hard-over left. The pilot held hard left rudder and ailerons until impact with the sea 30 seconds later, with the aircraft in a 108-degree bank and at more than 300 knots. Incorrect information presented to the crew, through a failure (horizon control reversal) in the flight director, contributed to the accident.

Source: ICAO ADREP Summary 78/5.

obscured by the pointer. The tip of the pointer should touch the end of the graduation scale but should not overlap it. The distance between the pointer and the surface of the scale may result in parallax which should be eliminated or minimized. There will be no such problem if the scale is displayed on an electronic display. In general, the size of the displayed information (e.g. scales and icons) must be positively related to the viewing distance (i.e. the longer the viewing distance, the larger the scale or icon size). This design consideration must allow for environmental correction factors like lighting, vibration and non-optimum viewing angles.

4.6.9 The introduction of electronic (e.g. cathode-ray tube) displays provided the opportunity to overcome many of the earlier constraints of electro-mechanical displays, permitted integration of displays, and afforded greater flexibility and a more effective use of panel space. Electronic displays generally have three applications on the flight deck: for flight instruments, systems information (e.g. engine data as well as data on other systems, including warning systems), and flight management systems (FMS). Electronic displays present a variety of ergonomics concerns, including: brightness and brightness contrast; the use of colours for different pieces of information; the fatiguing effect of extended periods of screen monitoring; the symbology utilized; what information should appear, and where, on the screen; and the fact — for reasons not yet very clear — that reading text from a screen is slower than from printed paper. On the other hand, electronic displays are generally cost-effective and versatile, and offer the user a reasonable amount of control over certain important display properties such as brightness and brightness contrast.

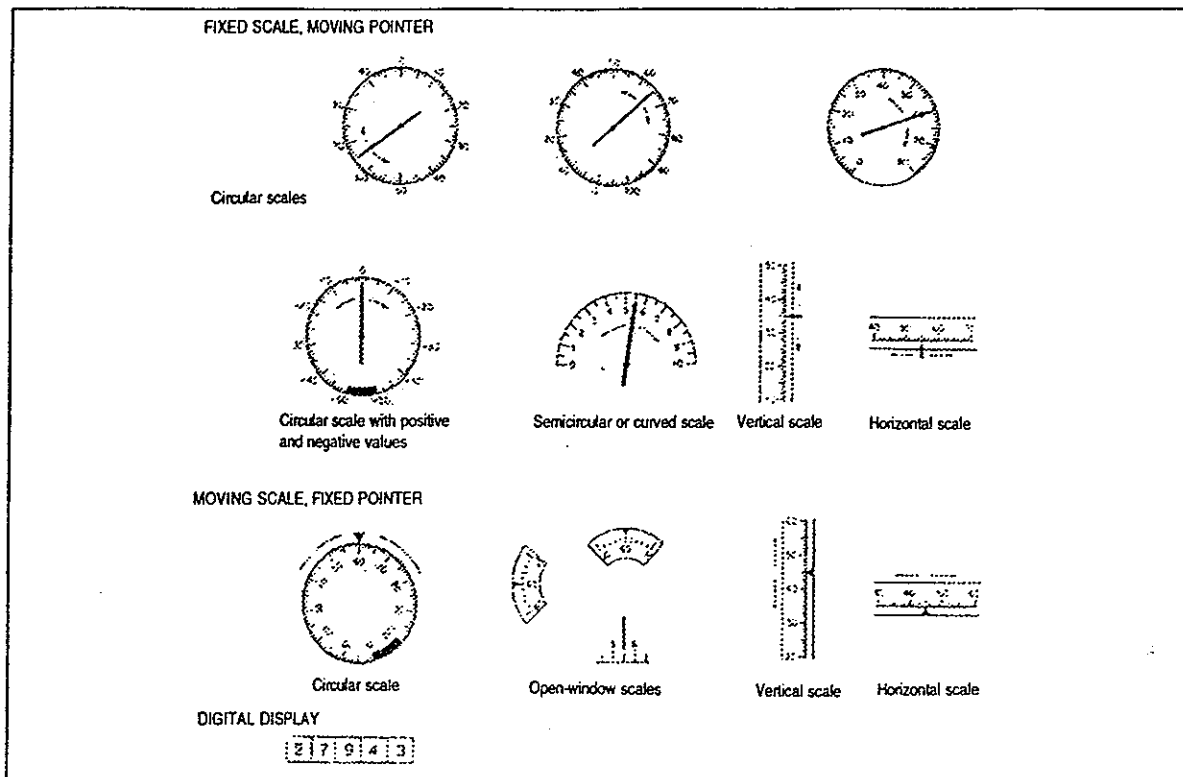

Figure 4-6. Example displays used in presenting quantitative information  
(adapted from McCormich *et al.*, 1983)

4.6.10 Many operators have introduced heads-up displays (HUDs) as an additional tool to allow for operations in lower weather minima. The symbology utilized by these devices must be common to the symbology utilized in screens.

#### Advisory, caution and warning (ACW) systems

4.6.11 Warnings signify a condition requiring an immediate crew action for maintaining the safety of the system, and their colour coding is normally RED. Cautions imply a condition which may become an emergency if allowed to progress or deteriorate. These usually require the appropriate, but not immediate, attention, and their coding is AMBER. Advisories are generally for information only, and may or may not require crew action. Their coding may be BLUE, WHITE, or GREEN. Three basic principles apply to the design of flight deck warning systems:

- they should *alert* the crew and draw their attention;
- they should *report* the nature of the condition; and

- preferably they should *provide guidance* regarding the appropriate action required.

4.6.12 Several considerations can be given to the last item. A good indication is provided by the number of aircraft which were involved in an accident because the crew shut down the wrong engine after an engine failure. Considerations in the design of the ACW systems include, first, system reliability, since confidence in a system will be lost if it is plagued by spurious warnings. Secondly, excessive appearance of an ACW signal will reduce response to it and become a nuisance. Lastly, auditory multi-warnings (i.e. the same sound being used to alert to more than one condition) require special considerations. They are effective in attracting attention, but may breed error or delay in corrective response. Voice messages may be added to enhance identification and interpretation.

4.6.13 Advisories, cautions, and warnings on the flight deck can be grouped into four broad categories:

- those which inform about performance, or departures from operational envelopes or safe flight profiles (e.g. for stall, overspeed and ground proximity); they are usually of high urgency;

In December 1974, a Boeing 727 crashed 12 minutes after departure from JFK airport. The airspeed and altitude values recorded in the FDR are consistent with the predicted climb performance until the aircraft reached 16,000 ft, when icing was encountered. The airspeed when the stick-shaker was activated was estimated to be 165 kt, compared to the 412 kt recorded by the FDR. The pitch attitude would have been 30 degrees nose-up.

The crew had not activated the pitot-heaters, and ice accumulated and blocked the pitot heads, producing erroneous airspeed and Mach warnings. They incorrectly diagnosed the stall warnings as Mach buffet and pulled the aircraft nose-up, which resulted in a stall and spin.

Source: NTSB AAR 75-13.

- those which inform about aircraft configuration (e.g. landing gear and flap positions);
- those which inform about the status of aircraft systems; these include limiting bands and flags on instruments; and
- those related to communications (e.g. SELCAL and interphone).

4.6.14 The following important principle must be reiterated: in the case of a failure, the user of a display should not be presented with unreliable information. The failure should be annunciated on the display itself, rather than on an indicator. It is very likely that, as long as the unreliable information is shown, sooner or later it will be used.

### Controls

4.6.15 Controls are means for the human operator to transmit messages or command inputs to the machine. The message should be transmitted within a specified accuracy and time period. Different types of controls perform different functions: they may be used to transmit discrete information (e.g. selecting a transponder code) or continuous information (e.g. cabin temperature selector).

They may send a control signal to a system (e.g. the flap lever) or control a display directly (e.g. an altimeter setting knob). As is the case with displays, the characteristics of the user population must be taken into account by the designer.

4.6.16 The functional requirements, as well as the manipulation force required, will determine the type and design of control to be adopted. An example checklist on how to select controls based on their functions is provided below.

<i>Function/force</i>	<i>Type of control</i>
Discrete functions and/or forces low	push buttons, toggle switches and rotary switches
Continuous function and/or forces low	rotary knobs, thumb wheels, small levers or cranks
High control forces	handwheels and large levers, large cranks and foot pedals

In December 1972, a Lockheed L-1011 crashed in the Everglades swamps near Miami. While the crew was attempting to replace a faulty nose gear indicator light bulb, the autopilot was inadvertently disconnected, and the aircraft descended to crash into the swamps. The nose gear light fixture had not been provided with a shadow divider between the two light bulbs, as is the usual design practice. The shadow divider allows the pilots to see that one-half of the fixture is dark when the first light bulb fails. The second bulb, while working, confirm to the crew that the gear is safely locked. This particular aircraft had been probably flying for several trips with an undetected failed light bulb in the nose gear fixture. The second light bulb failed when the aircraft was approaching Miami. This resulted in the highly improbable situation in which both light bulbs were inoperative simultaneously. The absence of the shadow divider was thus one of the factors which had contributed to the chain of events leading to an accident.

Source: ICAO ADREP Summary 72/557.

"... in cruise, first officer selected LP cock instead of adjacent fuel pumps during fuel balancing. No. 1 engine flamed out – instantly relit ..."

*Source: Feedback No.1, March 1983.*

"... taxiing out of dispersal we had reached the point in the checklist for 'flap selection'. The captain confirmed flaps to go to take off so I put my left hand down, grasped the knob and pushed downwards. Its travel felt remarkably smooth, so I looked down to find I had actually closed down the No. 2 HP cock shutting the starboard engine down. The top of the flap lever and the HP cock are immediately next to each other ..."

*Source: Feedback No. 2, July 1983.*

"... some readers may remember that we have published several reports about pilots who switched off the fuel cocks on BAC 1-11s by accident. BAe took the reports very seriously and put out a world-wide British Aerospace Policy Letter alerting all the operators to the possible problem. Not, perhaps, a cure – but certainly a step in the right direction."

*Source: Feedback No. 3, December 1983.*

4.6.17 Another basic requirement for controls, from the ergonomics point of view, is their location within the work area. However, it must be remembered that the optimal location for a display may not be optimal for reach.

4.6.18 Other design considerations include: control-display ratio, which is the ratio between the amount of change in a display in response to a control input and the amount of change in the control effected by the operator; and the direction of movement of display element (e.g. a pointer) relative to the direction of control movement. As shown in Figure 4-7, a rotary knob located on the right side of a longitudinal display should go clockwise to move the arrow indicator up. Control resistance affects the speed and precision of control operation, control "feel", smoothness of control movement and susceptibility of control to inadvertent operation. Control coding (i.e. shape, size, colour, labelling and location) aims to improve identification, and reduce errors and time taken in selection (see Figure 4-8). The last of the example principles in control design involves protection against inadvertent actuation. This can be achieved by methods such as gating, locking and interlocking (e.g. by interconnecting controls to guarantee that reverse thrust levers cannot be operated until thrust levers are in idle). In some cases, an action which is incompatible with existing conditions may trigger a visual or aural warning (e.g. closing the thrust levers when the landing gear is retracted will turn on an aural warning).

In one particular family of twin-jet transport aircraft, the engine fire switch is a powerful control with which one action shuts off the ignition, the fuel, the hydraulic fluid supply, and the pneumatic duct to the affected engine. Recognizing the consequences of improper actuation of this control, the designers went to great lengths to reduce the probability of this specific error. The fire switch has been given a unique shape and feel, and is located where it can easily be seen. The switch requires a long stroke, pull action unlike operating any other control on the flight deck. A light on the handle of the switch shows which engine is on fire. Finally, the handle is locked in the normal position unless a fire is sensed for that engine (although a manual override switch is also provided). It is located so that an additional discrete action is required for an operator to accomplish the procedure. This system has worked well for the management of engine fires since it was introduced 25 years ago.

*Source: "Error Tolerant Avionics and Displays", Delmar M. Fadden. Human Error Avoidance Techniques: Proceedings of the Second Conference. SAE P-229.*

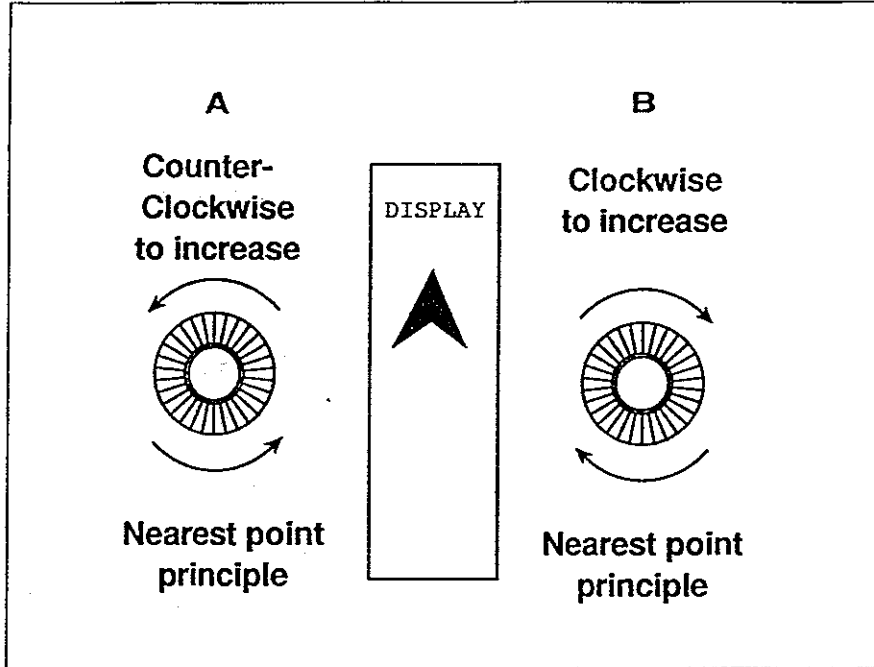

Figure 4-7. Two population stereotypes associated with this control-display relationship

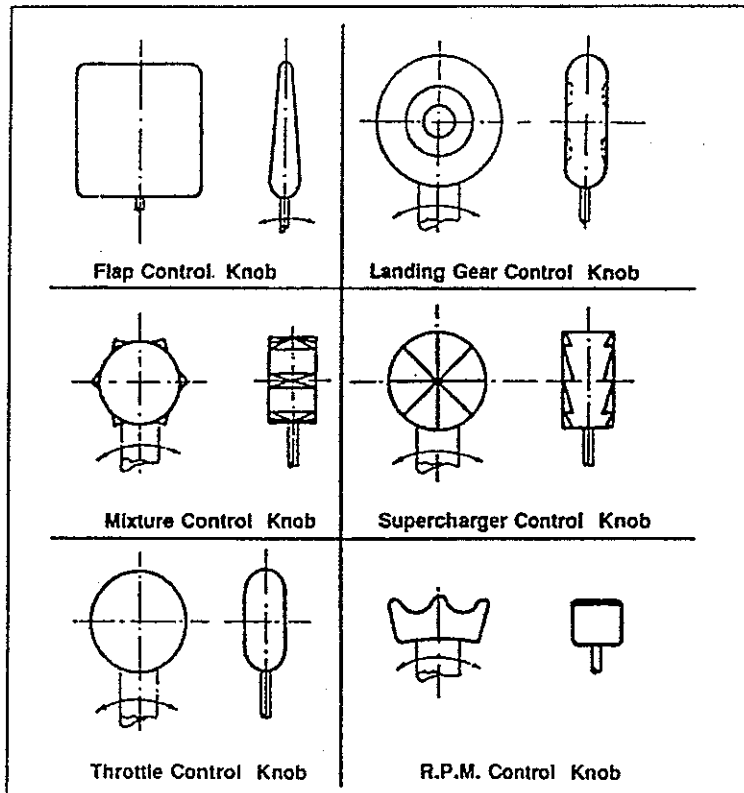

Figure 4-8. FAA requirements for cockpit control knobs (adapted from 14CFR, Ch. 1, Section 25.781)

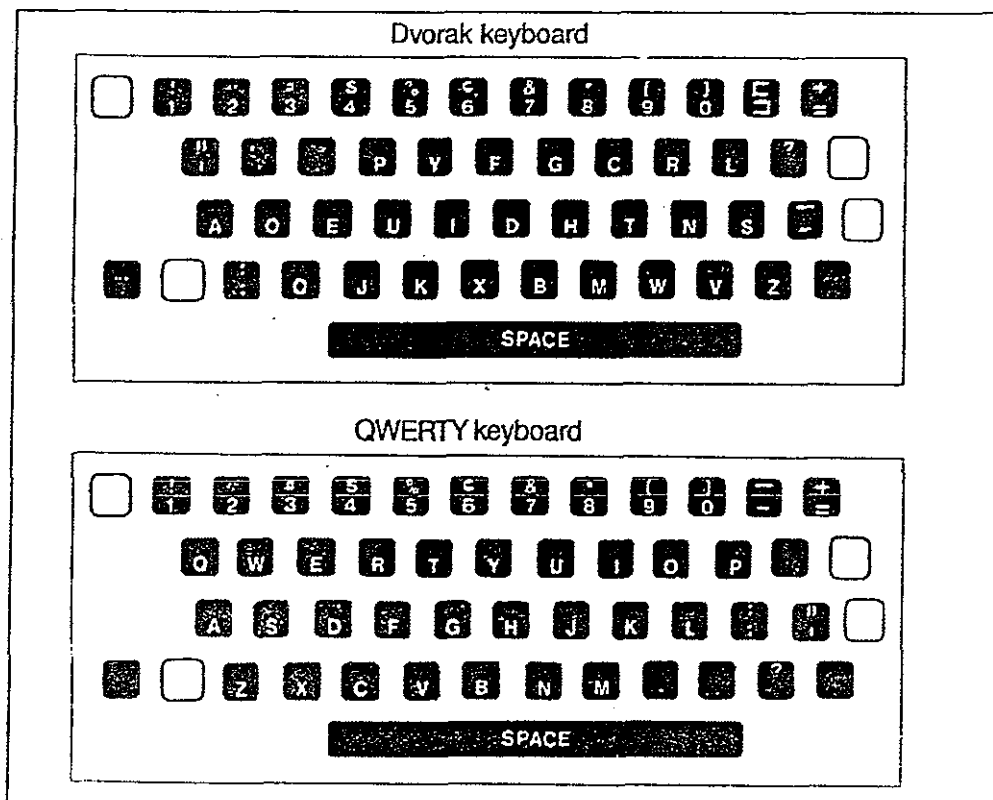

Figure 4-9. The traditional QWERTY keyboard and the more efficient Dvorak version

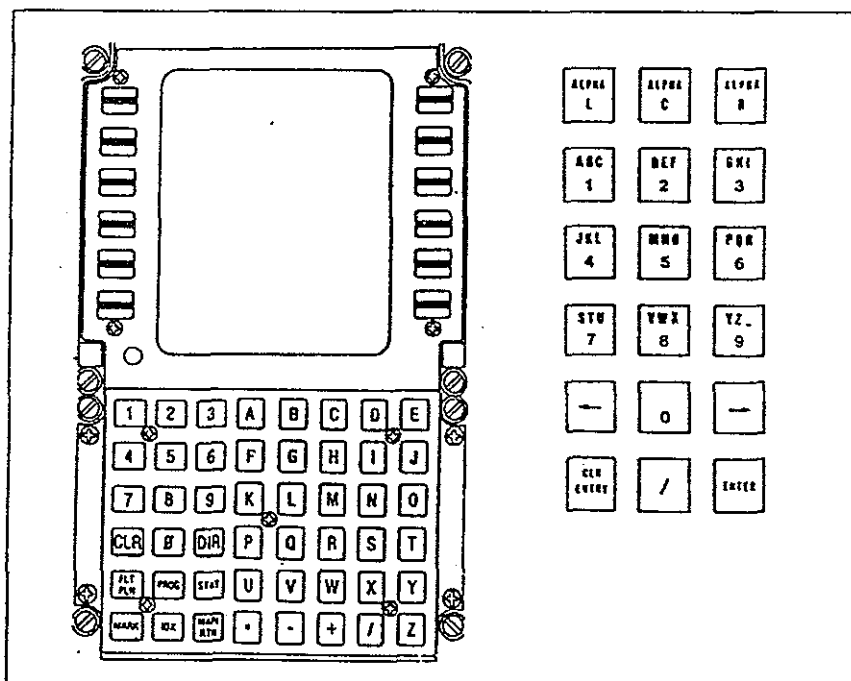

Figure 4-10. An example of a keyboard for a management or navigation system (left) and a suggested layout (adapted from *Human Factors*, L.C. Butterbaugh and T.H. Rockwell, 1982)

4.6.19 The use of keyboards on the flight deck has increased steadily over the years, as a consequence of the advent of computerization and modern avionics systems. An experienced typist can make one uncorrected error per 2 000 to 4 000 keystrokes. Flight deck crew members are generally considered to be unskilled typists. In addition, they may use the keyboard under adverse environmental conditions (e.g. under poor lighting and in turbulence). For on-board applications, accuracy and error detection are far more important than speed of entry. Key size, barriers between keys to prevent inadvertent operation and adequate handrests against vibration are some of the considerations in keyboard design. The traditional typewriter keyboard layout is named after the six initial letters of the top letter row (for example, QWERTY in English and AZERTY in French). DVORAK is an alternative layout, named after its originator, August Dvorak (see Figure 4-9). However, all of these configurations are generally unsuitable for flight deck applications because of space limitations and the need for single-handed operation. Figure 4-10 shows an example keyboard which has been adopted for many airborne navigational systems.

In July 1987, a Lockheed L-1011 flew within 100 ft of a Boeing 747 over the North Atlantic. It was later determined that the incident was due to a data input error made by the L-1011 crew. The crew allegedly had followed established data entry procedures by ensuring data entered was verified by another crew member; however, the input error still occurred. Subsequently, the crew did not follow established cross-check procedures, thus allowing the error to go unnoticed until the near collision occurred.

Source: ICAO ADREP Summary 87/331.

4.6.20 For many years, the flight deck was viewed as a common place where numerous otherwise unrelated systems, such as hydraulics, electrics, pneumatics and pressurization, converged. Each system was designed by a different group of specialists, and its associated controls and displays were largely driven by the particular functional specifications of the relevant system. The flight crew was thus presented with an assortment of displays, knobs, switches and controls of various sizes, shapes and markings, which were usually selected from different manufacturers' catalogues. The designer's main task was to make sure that all the equipment pieces were installed within the allocated space. This design approach has

generally failed to place emphasis on how to enable the crew to perform their tasks in the most efficient and effective manner.

4.6.21 In recent years, joint efforts by various civil and military industry groups, including manufacturers, airlines, pilots and authorities have led to the development of the concept of crew-system design. This concept emphasizes the functional integration of all system elements, taking into consideration the crew's requirements (e.g. for controls and displays). Factors integrated in the system design concept also include geometry of the flight deck, furnishings (e.g. seats, windows and glareshield), environmental variables (e.g. noise, vibration, light, temperature and weather), and miscellaneous fixtures (e.g. coffee cup holders, eating facilities, foot rests and baggage holders). They also include the characteristics of people who will operate and maintain all components of the system.

4.6.22 This systems approach to flight deck design is made possible by an activity known as systems engineering. The purpose of this activity is to develop relationships among system components, evaluate the effects of individual components on each other, and ultimately integrate all system components into one effective functional entity. Human operators, maintenance personnel and trainers are viewed as components of a system; thus, this approach considers the final product as a human-machine complex. The flight deck is therefore seen as a system, with the components of Liveware, Hardware, Software and Environment.

4.6.23 For effective design, contemporary systems engineering approaches incorporate ergonomics inputs, which in turn treat the flight deck as a workplace and take proper consideration of the capabilities and limitations of the users. Ergonomists aim to recognize and resolve potential Human Factors problems early in the design phase before any equipment is produced.

4.6.24 The ergonomics approach starts with an appraisal of task requirements and user characteristics which will affect design decisions such as those specifying the layout and makeup of the flight deck. In addition, the designer must take into account constraints which can limit design options. Such constraints include the aerodynamic characteristics of the aircraft, which are related to the cross-section of the fuselage and the shape of the nose. For example, the Concorde flight deck width of 148 cm, which is dictated by aerodynamic requirements, represents a relatively cramped environment when compared with a Boeing 747 which has a deck width of 191 cm.

4.6.25 Downward visibility during approach is a requirement which influences the design of the windshield



and the location of the design eye position (see Figure 4-11). The design eye position is an important reference point which helps to determine placement of equipment such as displays.

4.6.26 The distance between pilots' seats is a factor when cross-monitoring is required or when the same displays or controls are used by both pilots. Difficulties in access to pilots' seats may result in the decision to move the seats slightly outwards; however, proper consideration must be given to this misalignment of pilot and control so that it does not lead to hazardous conditions during operations.

4.6.27 Viewing distances for displays is another important aspect dictated by flight deck geometry. For large aircraft, typical viewing distances from the pilot's eyes are 71-78 cm for the main panel, 20 cm for the overhead panel, and 2 m for the lateral systems panel (see Figure 4-12). Size of display details (e.g. alphanumeric)

are determined by display location and distance from the eyes of the prospective user. Viewing distance issues are particularly applicable to persons wearing glasses. Viewing distances are also particularly relevant to "glass cockpits".

4.6.28 The panel containing flight instruments has received much attention from designers. The basic "T" layout which exists in most aircraft today is the result of the need for fast and accurate scanning of four basic parameters — speed, attitude, altitude and heading — with priority given to attitude (see Figure 4-13). Instrument panels which display system quantitative information (e.g. engine instrument panel) are arranged as a block or bank of instruments. A disturbance in the symmetrical pattern of that block as the result of a deviated indication on one of the instruments will be quickly detected by the crew. Synoptic panels (e.g. for the fuel, electrical, pneumatic and hydraulic systems) display the system in a schematic form with controls and displays appropriately placed. Flight guidance panels are generally mounted on the glareshield.

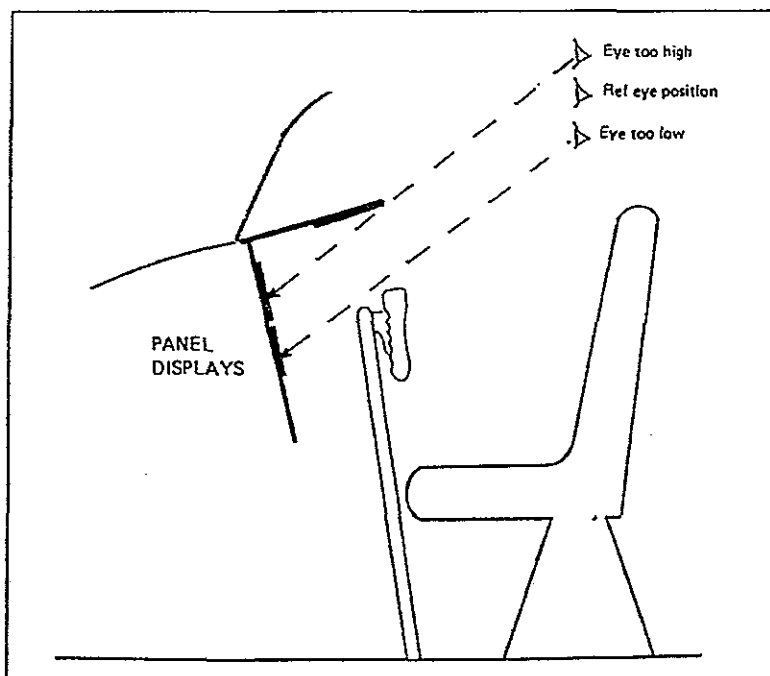

Figure 4-11. Reference eye position  
(adapted from *Human Factors in Flight*, F.H. Hawkins, 1987)

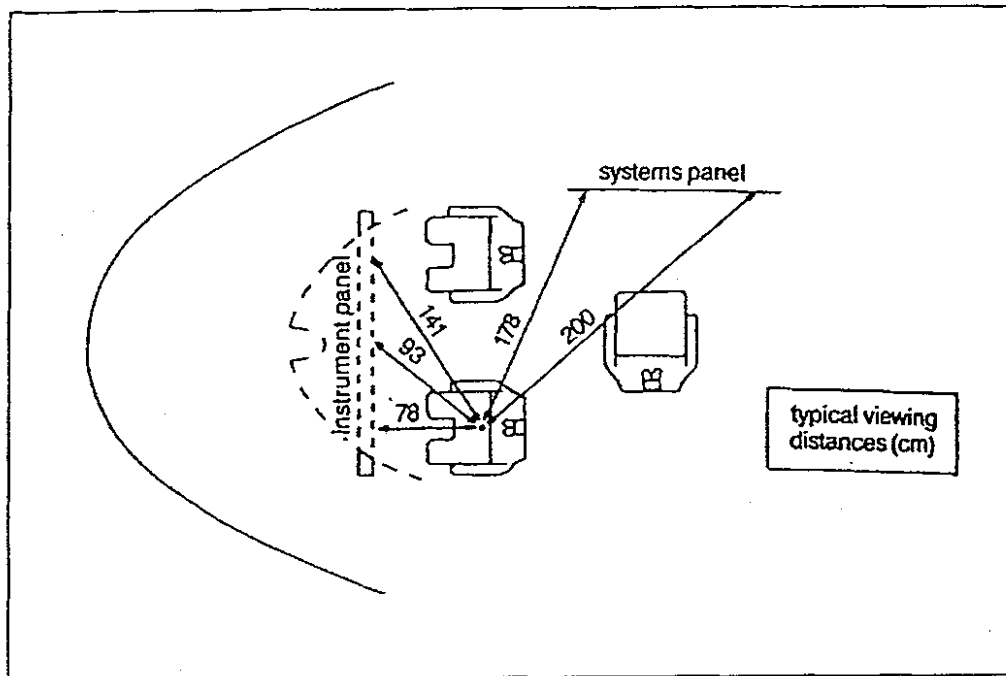

Figure 4-12. Typical viewing distances from the pilot's eye design eye position to various panels on the flight deck of a large jet (adapted from *Human Factors in Flight*, F.H. Hawkins, 1987)

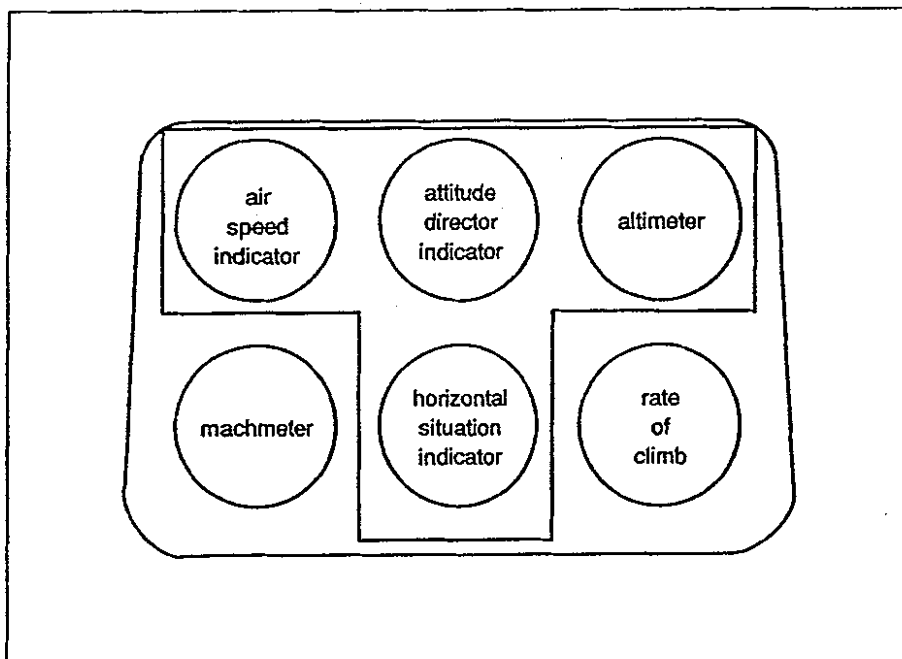

Figure 4-13. The "basic T panel" which forms the core of modern flight instrument panel layouts (adapted from *Human Factors in Flight*, F.H. Hawkins, 1987)

In January 1989, a Boeing 737-400 crashed short of the runway at East Midlands airport, near Kegworth, Leicestershire, UK. During climb to cruising altitude, a series of compressor stalls occurred in the No. 1 engine. The stalls were caused by a structural failure, giving rise to airframe shuddering, producing smoke and fumes on the flight deck, as well as generating fluctuations of the No. 1 engine parameters. Believing that the No. 2 engine had suffered damage, the crew throttled the engine back. The shuddering caused by the surging of engine No. 1 ceased when engine No. 2 was throttled back. This persuaded the crew that they had dealt correctly with the emergency. They then shut engine No. 2 down and diverted the plane to land. At 2.4 miles from the runway, there was an abrupt reduction of power and a fire warning from engine No. 1, then the aircraft crashed.

*Source: ICAO ADREP Summary 89/1.*

In its report, the British AAIB recommends evaluating the information presentation on new instruments and their effectiveness in transmitting the associated information to the flight crew. It also recommends that engine instrument systems be modified to include an attention getting mechanism which will alert the crew of system abnormalities. Figure 4-14 illustrates the proposed rearrangement.

This allows both pilots to reach them without having to lean over the control column, and improves instrument scanning. Figure 4-15 presents an example checklist for the evaluation of a typical flight guidance panel. Other panels which require proper ergonomics design include those for radio and interphone controls, circuit breakers, galley equipment, and door operation.

4.6.29 Toggle switches can follow either the "forward-on" (push switch forward to turn on) or "sweep-on" (see Figure 4-16) concepts. The forward-on concept presents a problem of ambiguity with panels mounted vertically or close to the vertical. It also lacks flexibility when modules have to be relocated, and the new switch positions no longer follow the forward-on concept. The sweep-on concept solves these difficulties. In multi-type fleets within a company, both concepts might be found.

This lack of standardization has been known to cause confusion and errors on the part of the crew.

4.6.30 Requirements for crew complement is another factor to consider in flight deck design and layout. On aircraft operated by three crew members, the third crew member may be sitting in front of a separate panel, facing it laterally, or may sit between the pilots, facing forward. Manufacturers have alternated between the two designs over the years. As a general rule, when systems complexity increases to the point of requiring extensive instrumentation, a separate station is required. On aircraft operated by two crew members, a large overhead panel is installed to accommodate controls which would otherwise be placed on the lateral panel. In general, overhead panels should have the most frequently used items located in the forward section, and the less frequently used items in the rear section, because the rear section is relatively inconvenient to reach.

4.6.31 The two- versus three-person crew issue has design implications which go beyond the basic process of relocating controls and displays. For instance, emergency response on two- person aircraft involving first stage failure of equipment with stand-by redundant module should require minimal crew intervention. Switching to the stand-by back-up module upon failure of the primary equipment should be automatic, obviating the need for manual input by a third crew member. However, the crew must still be informed of what has happened and provided with any other options required for further emergency action. In addition, activities and procedures which require prolonged heads-down time should be avoided to maximize opportunities for visual look-out.

In December 1983, an Airbus A300B4 crashed short of the runway at Kuala Lumpur during an approach under Instrument Meteorological Conditions (IMC). Among the contributory factors, it was indicated that the aircraft was on lease from another company, and its controls differed in some respects from the other A300's owned by the lessee company. The manual provided with the accident aircraft did not include details of some modifications which were made to the original instruments before the aircraft was transferred.

*Source: ICAO ADREP Summary 84/6.*

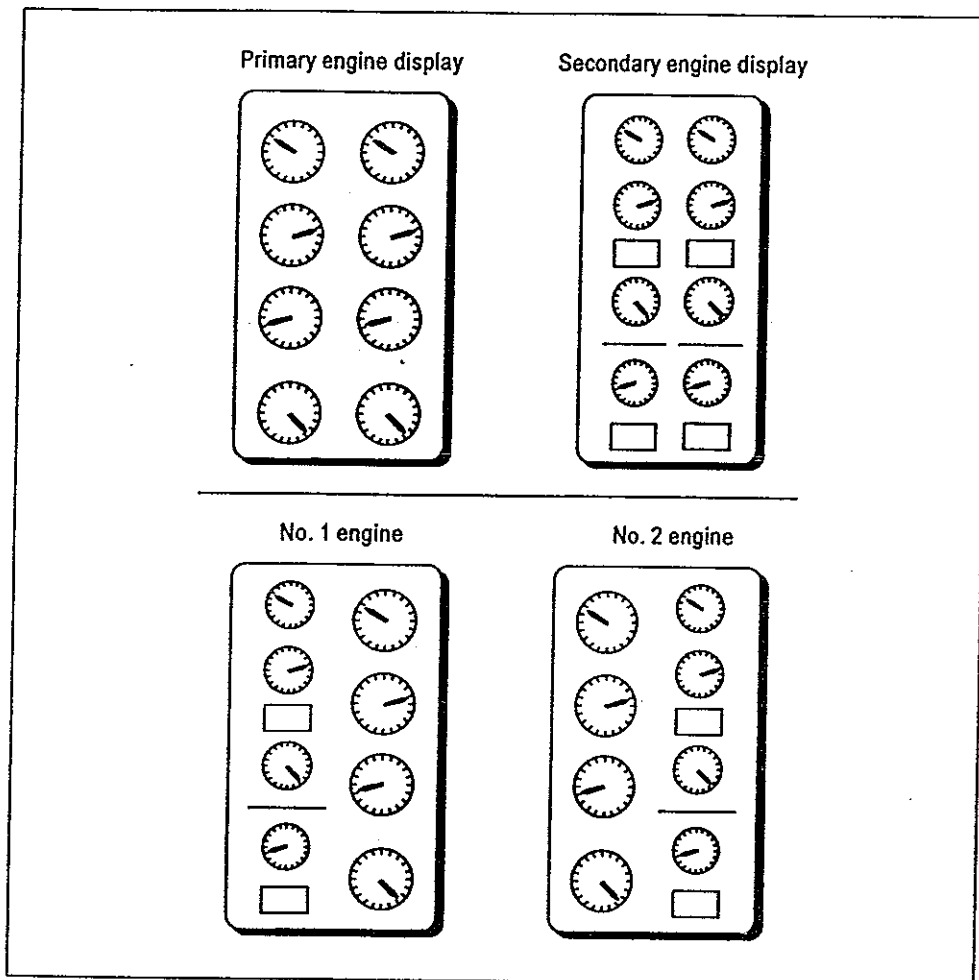

Figure 4#14. Proposed engine instrument system

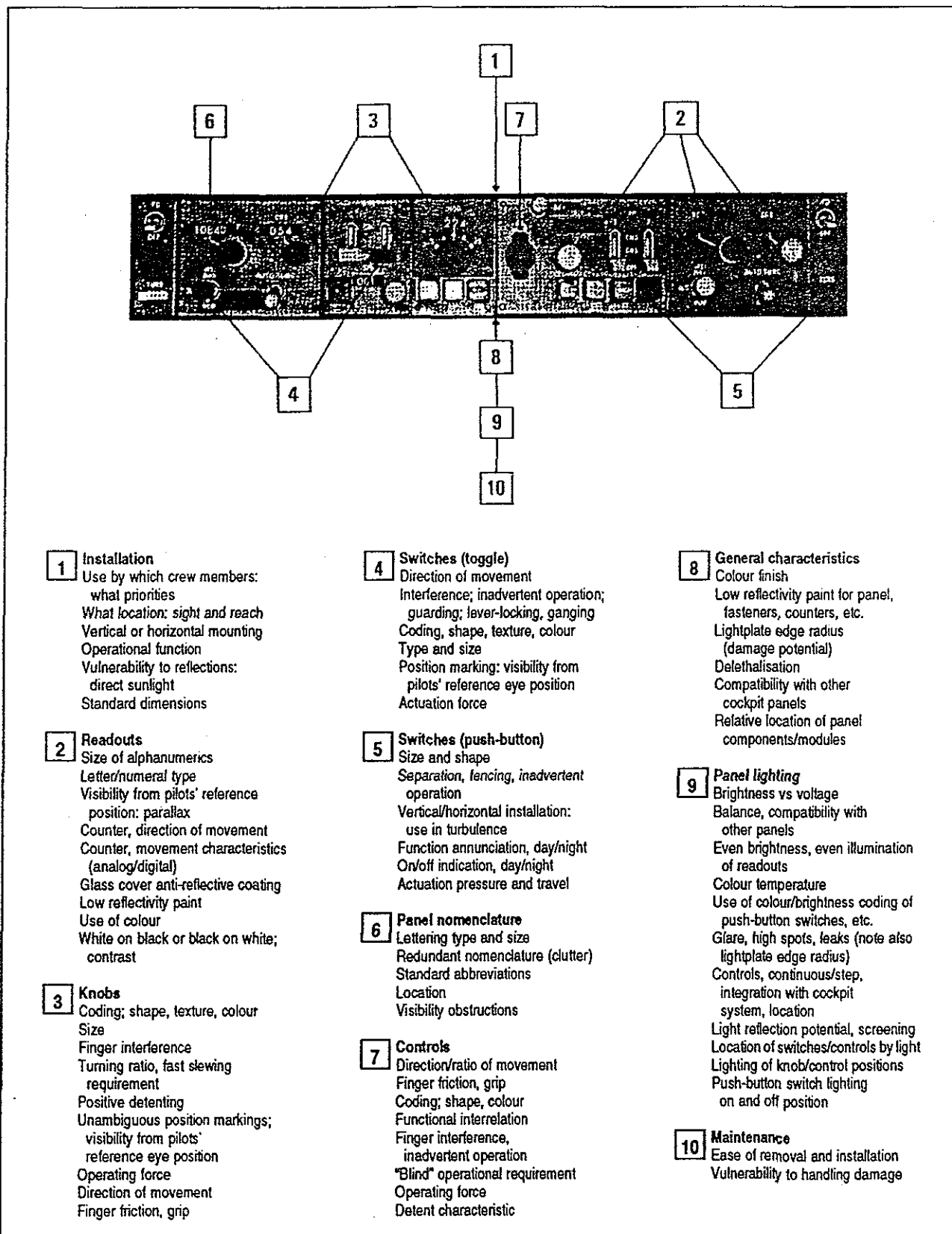

Figure 4-15. Checklist for evaluation of a typical cockpit panel

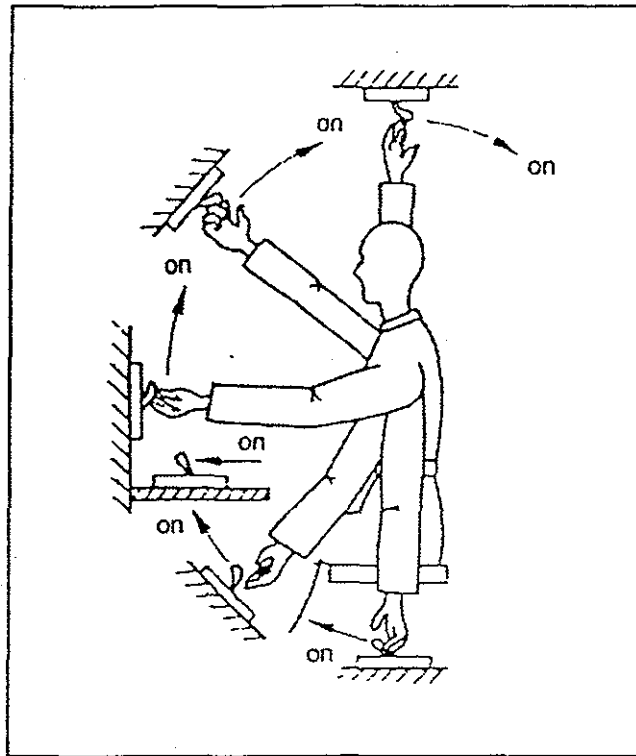

Figure 4-16. The "sweep-on" switch position concept which is slowly replacing the earlier "forward-on" arrangement (adapted from *Human Factors in Flight*, F.H. Hawkins, 1987)

4.6.32 General principles in seat design are equally applicable to flight deck and passenger seats. Some of those principles include distributing the body weight throughout the buttock region around the sitting bones, and providing a proper seat height to avoid excessive pressure on the back of the thighs. The spinal column should be kept in balance and maintain its relatively natural curvature by proper lumbosacral support and seat design. Armrests should provide the proper arm support while allowing free mobility of shoulders, arms and torso. In addition, consideration must be given to factors such as durability and weight of the material, flammability, structural integrity, reliability, space available, certification requirements and cost. Proper attention must also be directed to seat controls, restraint systems and footrests.

4.6.33 Pilots are required to remain strapped to their seats for many hours, and the effects of seat characteristics

go beyond the medical problems (e.g. back ailments) which may appear. Back pain or discomfort is distressing and can affect motivation, behaviour and performance.

## 4.7 THE ENVIRONMENT

### Stress

4.7.1 Stress was defined by Hans Selye as a non-specific response of the body to any demand made upon it.<sup>1</sup> This concept assumes that some "normal" or "optimal" state of bodily functions exists and that stressors (i.e. stimuli or situations that stress the person) cause a deviation from this normal state. Stress generally represents an attempt by the body to adapt to or cope with situational demands and to return to the normal state as

soon as possible. It can be differentiated into life stress, environmental stress and cognitive stress. *Life stress* is produced by adverse occurrences in a person's life (e.g. divorce, family bereavement). Environmental and cognitive stress are more closely related to the specific activities which humans undertake. *Environmental stress* includes the effects of factors such as temperature, humidity, noise, pressure, illumination and vibration. *Cognitive stress* refers to the cognitive (or mental) demands of the task itself. Countermeasures to minimize the potential untoward effects of environmental and cognitive stress are within the purview of ergonomics.

4.7.2 Stress has traditionally been linked to arousal, which refers to nonspecific changes (e.g. hormonal and brain activities) in the body to external stimulation. In general, stress and arousal levels are positively related — that is to say, high stress is associated with high arousal level. The Yerkes-Dodson law depicted in Figure 4-17 relates performance and arousal. It shows that people's performance levels increase according to the degree of arousal to a point beyond which any additional boost in arousal will generally be detrimental to task performance. The over-all shape of the relationship curve remains the

same across different tasks, but the exact shape and location of each curve vary according to task complexity.

4.7.3 Stress is related to a person's ability to pay attention to cues in the environment. In a simple situation with few cues, stress will improve performance by causing attention to be focused. In a complex situation with many cues, stress will decrease performance because many cues will go unheeded. This explains many accidents in which crew under stress "locked on" to some particular instrument which was defective (even if the instrument was of minor importance), failing to attend to other pieces of crucial information.

#### Noise

4.7.4 Noise is defined as any unwanted sound. There are two important aspects of noise which must be considered: the sources of noise, and the physiological and psychological effects on the person exposed to it. Noise affects a person in many ways depending on whether it is expected, whether it makes a task more difficult, and whether the person is relaxed or alert.

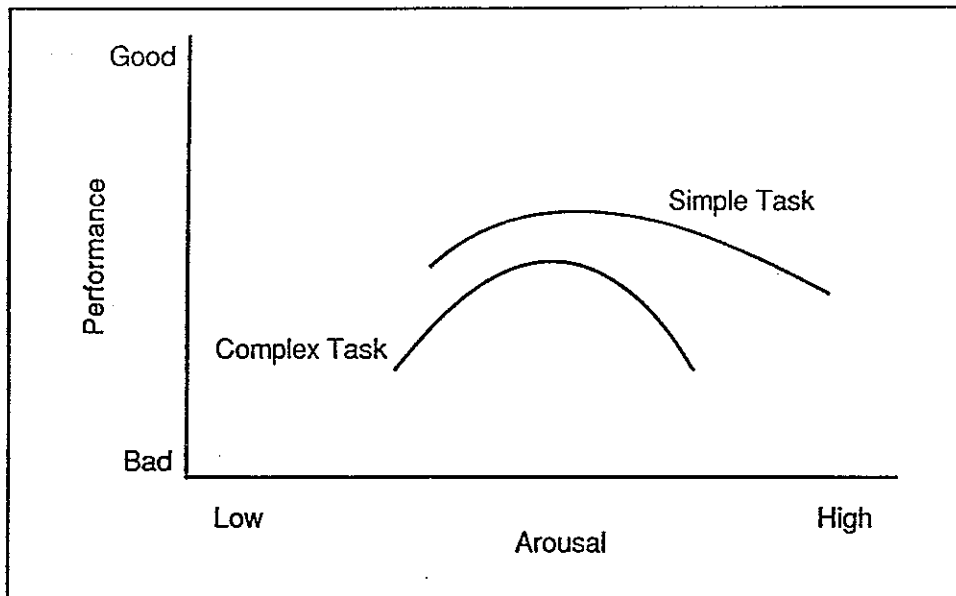

Figure 4-17. The Yerkes-Dodson law relating performance and arousal

4.7.5 Major sources of noise in fixed-wing aircraft include the engines, the air conditioning, pressurization and hydraulic systems, and boundary layer turbulence. Inside the aircraft, noise is louder near the sides of the fuselage than at the centre. Noise level in the cockpit is easily changed by the interaction of the airflow with the fuselage surface. Soundproofing will reduce noise, but it will increase aircraft weight as well. This has many undesirable effects such as increases in fuel cost. Design improvement to reduce noise at its source would be a better alternative. For example, removing the windshield wipers in one particular large jet transport reduced the flight deck noise level by 2 dB.

4.7.6 The most important pathogenic effect of noise, impaired hearing, has already been discussed in 4.2. Other physiological effects include changes in blood pressure and heart rate, headaches, tiredness and gastrointestinal problems such as ulcers. In the past, prolonged monitoring of high-frequency (HF) radio represented a significant exposure to noise. This has been alleviated by the introduction of selective calling (SELCAL). Technological progress in communications — as well as in other areas — will certainly provide new improvements in hearing protection. The fact remains, however, that crew members who are exposed to intense aircraft noise over a long period of time can be expected to suffer hearing loss in addition to the natural loss through ageing.

4.7.7 Noise affects performance by interfering with the detection and understanding of task-related signals or speech. It interferes with verbal communication by affecting the signal-to-noise ratio and by decreasing speech intelligibility. It further affects verbal communication by impairing hearing.

A twin-engine Beechcraft B-99 crashed during an instrument approach to the Shenandoah Valley Airport, Virginia, in September 1985. The NTSB concluded that among the factors which contributed to the flightcrew's errors was "... intracockpit communications difficulties associated with high ambient noise levels in the airplane ..."

Source: ICAO ADREP Summary 88/4.

4.7.8 Because it is annoying for most people, noise can have an impact on psychological conditions. On the flight deck, this annoyance is compounded by the prob-

lems noise generates in communication. This may result in frustration and anxiety over the need to repeat messages or to understand them. This in turn may increase workload and fatigue. While it is the ergonomist's task to try to minimize noise through design and by providing hearing protection, crew members should be aware of the insidious effects of noise and the damage it can provoke, and of methods to reduce noise levels or to protect oneself from its detrimental effects.

## Temperature

4.7.9 Temperature extremes are one of the most common environmental stressors. Since humans are comfortable only over a narrow band of temperatures, it is necessary to know how well they function at different temperature levels before remedial measures can be derived. Questions about air-conditioning requirements and human performance under heat or cold stress should be answered and taken into account during system design. Cabin environmental control systems are the principal means for controlling the internal aircraft environment.

4.7.10 Humans generate heat while performing mechanical work, and to a lesser extent, when resting. The excess heat is transferred to the environment, primarily by perspiration and sweating, in order to maintain a relatively constant body temperature of 37 degrees Celsius (C). The success of body temperature regulation depends on various factors: ambient temperature, humidity, and air velocity. If body temperature increases by more than 2 degrees C, physiological efficiency will be impaired.

In February 1984, a Cessna T-303 crashed during landing at Hickory, North Carolina, U.S.A. The aircraft overran the runway and collided with a fence. The pilot was hampered by an inoperative heater and a dome light that could not be turned off.

4.7.11 The physiological effects of ambient temperature extremes are well known, but the effects of heat stress on human performance are more complex. It is generally accepted that excessive heat will cause performance decrement, but there is little agreement regarding how much decrement will take place, or how long it will take to occur. People can withstand exposure to excessive temperatures for only a short period of time before measurable degradation sets in. Acclimatization prolongs



this period. In non-acclimatized persons, degradation appears when the ambient temperature exceeds 30 degrees C, the relative humidity is high, and exposure exceeds three hours. Obviously, clothing and physical activity level play important roles, too.

4.7.12 When exposed to cold, the body attempts to maintain its core temperature by shivering and restricting blood flow to the body surface. Body temperatures below 35 degrees C are dangerous. Consciousness becomes clouded at 34 degrees C, unconsciousness follows around 30 degrees C, cardiac irregularities are usual between 30 and 28 degrees C, and death is imminent. Although humidity is not a factor, air velocity is important; as a result, wind chill indices are increasingly being provided in weather reports. (Wind chill is not a psychological effect — it effectively lowers body temperature.) Cold increases both reaction and movement time, and manual dexterity begins to deteriorate when hand-skin temperature falls below 18 degrees C.

#### Humidity

4.7.13 Humidity may become an issue with high-altitude jet transport aircraft because of the low relative humidity at their operational altitudes. The discomfort arising from low relative humidity may not imply physical indisposition. Over-all dehydration can be prevented with adequate fluid intake. Diuretics like coffee or tea should be avoided. The installation of humidifiers on aircraft could raise cabin/cockpit humidity, but there are potential problems such as weight penalty, condensation and mineral contaminations that the designer must consider.

#### Pressure

4.7.14 Cabin pressurization eliminates many problems associated with high altitude flying, but it introduces other potential problems, the most important being the risk of a rapid decompression. The time of useful consciousness (TUC) following a rapid decompression depends on aircraft altitude, the rate at which pressure falls, and the level of physical activity of the individual at the time of the event. At typical jet transport aircraft altitudes (35 000 feet) TUC will vary between 33 and 54 seconds. Those average values can be expected to drop by a half at 40 000 feet. This emphasizes the importance of immediate availability of supplemental oxygen to crew members.

4.7.15 The technical reliability of automatic delivery systems, as well as the design of certain types of flight crew quick-donning masks have sometimes been sub-

optimal. It should be borne in mind that oxygen systems will be used in conditions accompanied by anxiety and other stressors, and simplicity of use and reliability are of utmost importance.

#### Illumination

4.7.16 The nature and quantity of cockpit illumination required for a certain task may vary considerably. Factors of importance are the speed and accuracy with which the displays must be read, the ambient illumination, other light sources (in particular, sunshine), and the presence of glare. Glare is defined as a condition of vision where there is discomfort or a reduction in the ability to see significant objects, or both, due to an unsuitable distribution or range of luminance (i.e. density of light, or light intensity per unit projected area) or to extreme contrasts in space or time.

4.7.17 Glare is an important aspect of the quality of the illuminated environment. It can be caused by bright light sources or light reflection off environmental surfaces. Glare may produce discomfort or annoyance, and may interfere with visual performance. The type of reflection off surfaces depends on the properties of the surface (e.g. whether it is polished, rough or matted). Some evidence suggests that there is an element of subjectivity in tolerance to glare. The most effective techniques for reducing glare include blocking the glare surface or placing supplementary lighting to offset the effects of glare.

#### Vibration

4.7.18 Vibration is any form of oscillating motion that changes its magnitude of displacement periodically with reference to a point, and it is a widespread physical phenomenon. The movement of pistons within the cylinders of engines or the disturbances generated in aircraft flying through turbulent air are forms of vibration which can be transmitted to humans. Vibration is generally transmitted through direct contact between the body and the vibrating structure, and it can have potentially harmful effects.

4.7.19 Vibration is of operational significance in aviation because it may impair visual acuity, interfere with neuromuscular control and lead to fatigue. Although better than before, high levels of vibration can still be encountered in helicopters as well as in fixed-wing aircraft during low-level flight.

4.7.20 Protection against vibration can be provided by attention to its source, by modification of the trans-

mission pathway or by the alteration of the dynamic properties of the aircraft body. Reduction of vibration emanating from aircraft engines is a primary task for design and maintenance engineers. The installation of devices called dynamic vibration absorbers has reduced vibration levels on helicopters. Another ergonomic approach is by means of vibration isolation of the flight crew seats.

#### LIST OF REFERENCES

- Chapanis, A. *Man-machine engineering*. 1965. Belmont, California, U.S.A.. Wadsworth.
- Damon, A., Stoudt, H.W., and McFarland, R.A. *The Human Body in Equipment Design*. 1966. Cambridge, Massachusetts, U.S.A. Harvard.
- Edwards and Edwards. *The Aircraft Cabin*. Gower Technical Press.
- Ernsting and King. *Aviation Medicine*. Butterworths.
- Grandjean, E. *Fitting the Task to the Man: An Ergonomic Approach*. 1980. London, United Kingdom. Taylor and Francis.
- Hawkins, Frank H. *Human Factors in Flight*. Gower Technical Press.
- Kantowitz and Sorkin. *Human Factors, Understanding People-System Relationships*. John Wiley and Sons.
- O'Hare and Roscoe. *Flightdeck Performance: The Human Factor*. Iowa State University Press, Ames, Iowa, U.S.A.
- Roscoe, S. (Ed.) *Aviation psychology*. 1980. Iowa State University Press, Ames, Iowa, U.S.A.
- Salvendy (Ed). *Handbook of Human Factors*. John Wiley and Sons.
- Sanders and McCormick. *Human Factors in Engineering and Design*, McGraw-Hill.
- Shackel, B. (Ed). *Applied ergonomics handbook*. 1974. IPC Science and Technology Press. Surrey, England.
- Sloan and Cooper. *Pilots under Stress*. Routledge and Keegan Paul.
- Stokes, Wickens and Kite. *Display Technology, Human Factors Concepts*. Society of Automotive Engineers.
- Wiener and Nagel. *Human Factors in Aviation*. Academic Press.
- ICAO *Manual of Civil Aviation Medicine* (Doc 8984).
-

## Chapter 5

# HUMAN FACTORS ISSUES IN AIR TRAFFIC CONTROL

### 5.1 INTRODUCTION

This chapter deals with Human Factors issues related to air traffic control (ATC). Its objective is to provide practical Human Factors guidance to those concerned with ATC systems. It is intended to show how human capabilities and limitations can influence task performance and safety in ATC. Sources of Human Factors knowledge are also identified. This chapter:

- describes how to consider Human Factors within a system;
- explains the Human Factors issues raised by the introduction of automation in ATC;
- outlines selection criteria for controllers and discusses issues regarding air traffic controller training, including Team Resource Management (TRM) training and Threat and Error Management (TEM);
- considers specific human attributes relevant to ATC systems; and
- provides a list of references.

### 5.2 HUMAN FACTORS WITHIN SYSTEMS

5.2.1 Throughout this chapter, various Human Factors topics are discussed separately as a convenient way to describe them. In practice, these topics are never separate but always interact significantly with each other. No real-life Human Factors issue in ATC can ever be addressed completely under a single heading. For example, any ATC workspace specification will have implications for task design, performance, skill and error, and probably also for training and team functions. The SHEL model<sup>1</sup> can be used

to identify problem areas, to trace the origins of specific problems and to define appropriate data collection tasks. The SHEL model includes the main interactions between the human and other aspects of the system, but there can be second and third order interactions also. For example, what a controller (liveware) actually sees on a display can depend on which information is displayed (hardware), how appropriate it is for the task (software), whether it is obscured by glare (environment) and what the controller is expecting to see after conversing with the pilot (liveware).

5.2.2 An ATC system aims to achieve a safe, orderly and expeditious flow of air traffic and is an example of a large human-machine system<sup>2</sup>. In such systems, humans interact with machines to fulfil the functions of the system. However, individual humans do not usually all have the same tasks, jobs, equipment or functions, although they may have similar professional training and qualifications. A safe and efficient ATC system must include appropriate technology. It must also have trained and knowledgeable professional air traffic controllers who can understand and use all available facilities to provide a satisfactory ATC service.

5.2.3 In addition to safety, orderliness and expedition, the ATC system has several less known objectives — fuel conservation; noise abatement; minimum environmental disturbance; cost effectiveness (increasingly becoming important as a result of the corporatization of ATC); impartiality towards all users within the rules and regulations; and the granting of users' requests whenever possible. A subsidiary but vital aim is to ensure the continued provision of a workforce of controllers who can fulfil the standards, policies and objectives of ATC with existing and new facilities and equipment. This implies that a considerable amount of effort in an ATC organization is aimed at training air traffic controllers, and ATC systems development, for both of which the input and participation of operational air traffic controllers is essential. This should be reflected in the size of the controller workforce.

Examples of the SHEL interfaces for ATC are:

- |                       |   |
|-----------------------|---|
| Liveware-software:    | <ul style="list-style-type: none"> <li>* Existing differences in altimeter setting procedures (inches vs. hectoPascals; height of transition altitudes and/or levels) may lead to errors by crews who operate in foreign or unfamiliar airspace;</li> <li>* National or local ATC procedures manuals are not up-to-date with applied operational procedures;</li> </ul> |
| Liveware-hardware:    | <ul style="list-style-type: none"> <li>* Adjustable chairs with wheels are often more comfortable than rigid chairs with traditional legs;</li> <li>* Adequacy of headsets that are provided;</li> </ul>  |
| Liveware-environment: | <ul style="list-style-type: none"> <li>* Provision of temperature-control and/or air conditioning in the operations rooms;</li> <li>* In towers: slanted windows, tinted glass, etc. Also, positioning of the tower to avoid looking into the sun most of the day;</li> </ul>   |
| Liveware-liveware:    | <ul style="list-style-type: none"> <li>* Every aspect of coordination and communication;</li> <li>* Employee-employer relationship.</li> </ul>  |

### Matching human and machine

5.2.4 Most Human Factors issues in ATC are not new but derive from fundamental human capabilities and limitations. Yet Human Factors has to respond to changes that originate elsewhere, for example in increased air traffic demands or technological advancements. The achievement of the full expected benefits of these advancements requires the successful matching of human and machine, so that humans do not slow down technical progress because they have been given tasks beyond their capabilities. The aim of Human Factors in ATC is to match the specifications and design of the ATC system with human capabilities and limitations. This matching of human and system is an active process, the achievement of which may imply changes to either or both. Successful matching requires the correct application of the extensive Human Factors data available.

5.2.5 The air traffic controller needs to have an understanding of how the air traffic control system has been designed and can function, in order to interact with it and contribute the benefits of the controller's professional knowledge. The fundamental reason for applying Human Factors to ATC is to improve safety and help prevent accidents, while improving the efficiency of the system.

### Developments in air traffic control

5.2.6 Recent years have seen an inexorable growth of air traffic worldwide. The introduction of larger and faster aircraft together with an increasing number of smaller aircraft has required ATC to handle a greater variety of aircraft types. Despite more efficient equipment in the air and on the ground and more intensive and productive use of the ATC system, peaks of air traffic at or near maximum ATC system capacity have become more common and more prolonged.

5.2.7 In many parts of the world, future air traffic demands are expected to exceed the capacities of current ATC systems, which must therefore evolve or be replaced in order to cope safely and efficiently with these higher demands. Further sectorization of the airspace eventually becomes counter-productive as a solution because of the extra coordination and liaison work incurred. Alternative solutions have to be devised, proved and implemented. They include:

- the provision of better data to the controller;
- the replacement of manual functions by automated versions;

- automated data handling and presentation;
- automated assistance for cognitive human tasks such as problem solving and decision making;
- flexible use of airspace, based on operational requirements rather than geographical boundaries;
- a change from short-term, tactical interventions which solve problems that arise, to strategic pre-planning of efficient traffic flows to prevent problems from arising.

5.2.8 At times, systems become overloaded and flow controls have to be imposed: air traffic flow management (ATFM) is nowadays a normal process in busy areas to coordinate the planning of the flow of air traffic across sectors and FIRs. Although ATFM is basically a strategic tool to prevent overloading of the air traffic control systems, experience as an air traffic controller and thorough knowledge of the area are needed to plan the traffic flows. The objective of ATFM as applied in Europe is not to control airborne aircraft but to minimize delays by allocating departure slots and routes to aircraft still on the ground. In the United States a form of ATFM was developed in which a central unit (Washington) can intervene in airborne traffic to optimize the flow, e.g. to a specific destination, or around weather systems.

5.2.9 Further factors can aggravate the difficult circumstances that ATC is facing. The size of the controller workforce may remain about the same, even when more controllers are needed because of the increase of traffic. More controllers may also be needed if new technology allows the applicable separation criteria between aircraft to be lowered, which not only achieves intended increases in the traffic handling capacity of the system but also requires the controller to intervene more quickly if the separation criteria are not maintained. The runway, departure route or approach pattern preferred by the controller or pilot may not be available due to noise abatement restrictions.

5.2.10 The techniques of air traffic management are constantly changing. New data link and satellite communication methods are evolving, the quality of radar and data processing is improving, collision avoidance systems are being developed and implemented, direct routing of aircraft between departure and arrival airports instead of via airways is being explored, and advanced air navigation systems are being researched. The further options offered by such technological advances also have to be considered in terms of safety, efficiency, cost effectiveness and compatibility with human capabilities and limitations. These advances change the procedures and practices of

ATC, the working environment and the role of controllers, presenting all involved with the challenge not to overlook the Human Factors issues. The paramount requirement of safety must never be compromised in ATC, but maintained and enhanced throughout all future changes.

### Transfer of information

5.2.11 The objectives of ATC are to prevent collisions between aircraft and avoid other potential hazards by means which nevertheless promote efficiency of flight. How these are achieved depends on many factors, including:

- the characteristics of each aircraft and its equipment;
- the nature and degree of control over the traffic that is exercised;
- applicable rules, principles and procedures;
- the means for exercising control over air traffic;
- the knowledge, skill and experience of the pilot;
- the knowledge, skill and experience of the controller;
- the quantity, density and mix of air traffic;
- the information available on each aircraft;
- environmental factors, including ground equipment, terrain and weather.

5.2.12 Information about aircraft is of two kinds, quantitative and qualitative. Quantitative information — e.g. on position, flight level, speed, heading and manoeuvres — can generally be expressed and communicated digitally, and presented on displays. Qualitative information — e.g. on the reliability, validity and trustworthiness of data — is not usually displayed but depends on how the information is sensed and processed, particularly in terms of its frequency of updating, accuracy, precision, and the kinds of error, failure or degradation to which it may be susceptible. The experienced controller learns to recognize and adjust to information of poor quality.

5.2.13 Qualitative information often determines how closely together aircraft may fly safely, and hence sets the capacity of the ATC system in most circumstances, although other factors such as wake turbulence minima or the number and availability of runways may have an impact

on capacity. The permissible separation between aircraft can generally be smaller in a radar environment (when the information about them is of high quality and frequently updated) than when they are beyond radar coverage and procedural separation criteria are applied. The improved high-accuracy navigation capabilities of the latest generation of aircraft can also be regarded as enabling the application of reduced separation standards.

### The controller's workspace<sup>3</sup>

5.2.14 Air traffic control workspaces must remain safe and efficient under the most unfavourable conditions that are permissible. This applies to attributes of liveware (such as minimum eyesight standards), of hardware (such as equipment about to be replaced), of software (such as non-standard procedures), and of environment (such as glare from sunlight). Workspaces must therefore be tested and validated for these conditions and not for average or optimum ones. Each workspace must take account of the information to be portrayed, of the types of controls needed for each task and their layout in relation to each other and to displays, and of the furniture design. This requires the thorough application of proven ergonomic evidence for the positioning, layout, separation and coding of controls and of displayed information. To compromise these principles can lead to poorer performance that takes longer, is more prone to error and can endanger safety.

5.2.15 Decisions about workspaces and design pre-determine many of the kinds of human error that are possible and which sooner or later will occur. This applies particularly to decisions about the displays and codings, the types and sensitivities of control and input devices, the layout of equipment in the workspace, communication channels and the means to activate them, and the perceived relationships between displays and input devices.

### Communications

5.2.16 The communication facilities available at the workspace need to be evident. Communications are primarily software, accessed through hardware. They have to be integrated into the workspace, with a clear and unambiguous indication whenever a communication channel is already in use. They must provide a positive indication of successful transmission. Hitherto, much of the information transmitted between one controller and another and between pilots and controllers has been by speech (a liveware-liveware interface) and the message formats have included formal acknowledgement that each message has been received and understood. In the future, more

information will be transmitted automatically between aircraft and ground systems, between satellites and computers and through various other communication systems, without the direct participation or involvement of the controller. The controller has no knowledge of such information unless deliberate provision for informing the controller has been included. The roles of groups and teams are often reduced when communications are automated, since the human link with the machine through the human-machine interface is usually accessible to one controller but not to a team of controllers.

Example: In a traditional ATC environment with voice communications, it is not uncommon for a controller at an adjacent working position to overhear an erroneous instruction or readback error in a transmission by a controller at another position, or spot a readback error by a pilot to another controller. In a more automated environment (e.g. with Controller Pilot Data Link Communications (CPDLC) as the primary means of communication) this extra defence does not exist.

5.2.17 For many years to come, ATC systems will continue to contain a mixture of various kinds of communication. ATC must provide a service for types of aircraft which vary greatly in their on-board communications equipment. The controller has to understand and integrate all the types of information that may be encountered. If there are automated aids to communications, the controller must know how these function. Different types of communicated information can be combined and reconciled only in ways that are practical within the human-machine interface design.

5.2.18 To avoid ambiguity and potential sources of error, the content, structure, dialogues, vocabulary and sequences of spoken ATC messages have been standardized as much as possible. Much of this was done many years ago. The ICAO spelling alphabet was the product of extensive research to choose a set of words which would sound as different from each other as possible, even when spoken over noisy and degraded communication channels by people whose native language was not English. The ICAO spelling alphabet has proved to be efficient, and further research on it would be unlikely to achieve significant improvements. (However, its suitability for recognition by humans does not imply its suitability for recognition by machines.)

5.2.19 The main sources of phonetic confusions and similarities are well established. Aircraft with similar call signs within the same airspace must inevitably be a potential cause of human error, and such circumstances are best avoided by preplanning. Whenever aircraft may fly in the same area at some stage during their flight, very different call signs should be assigned to those aircraft. Ambiguity can be curtailed by always giving the contents of ATC messages in standard formats and in standard order. This reduces the possibility that one kind of information will be mistaken for another.

Example: The figure "250" could either mean a flight level, a heading or a speed, and could even be the flight number-part of a call sign. It is obvious that without adhering to standard procedures, there is a large potential for ambiguity here.

5.2.20 Communications can be improved by good controller and pilot discipline. It is always important to speak slowly and clearly, especially when the language used is not the native language of either the speaker or the listener. Towards the end of a long shift or a long flight, the controller or pilot may be tired and speech should be particularly slow and clear. Voices become familiar, and it can confuse the pilot if a different controller from the one expected replies, and confuse the controller if parts of a single dialogue with the crew of an aircraft are with different crew members. Transmissions where the start or the end of a message is cut off can be potentially dangerous, especially if the controller is busy, which is when this is most likely to happen. Routine confirmation of messages and requests to repeat them if there is any uncertainty can help to prevent errors. Particular care is needed to counteract the human propensity to hear what is expected rather than what is actually said.

Example: In a situation where one aircraft has just touched down on the runway and the next aircraft reports on final (e.g. over the Outer Marker), the controller will normally reply to the aircraft on final that it is "number one". Quite often in that situation, the pilot will read back "cleared to land", since that is what he was expecting to hear.

5.2.21 Similar to the development of the ICAO spelling alphabet for voice communications, standards are being introduced by ICAO for use in Controller Pilot Data Link Communications (CPDLC). Before implementing CPDLC it is of the utmost importance that Human Factors issues be fully considered, both for the cockpit and the ground-based side.

### 5.3 AUTOMATION IN AIR TRAFFIC CONTROL

#### Full or partial automation

5.3.1 Many modern ATC systems include some functions, for example in data gathering and processing, which are fully automated with no direct human intervention. These functions may have significant Human Factors implications, for example if the controller is not able to discover whether fully automated functions have occurred or have been successful. If any of these fully automated functions were previously fulfilled by the controller, the absence of the knowledge formerly gained by fulfilling them may be experienced by the controller as an apparent loss of situational awareness.

5.3.2 This section is primarily concerned with a different form of automation in ATC, in which the automation of a function is partial or incomplete and intended to assist the controller. The Human Factors implications of such forms of automation are direct and immediate. They pose problems of human-machine relationships which have to be identified and resolved during the system design process, with subsequent confirmation that the operational objectives of the automation have been achieved. They relate primarily to the liveware-software interface.

#### Reasons for automation

5.3.3 There are several reasons for the progressive introduction of automation into ATC systems. One concerns technological and navigational advances which provide more accurate, precise, reliable and up-to-date data about the position of each aircraft, its plans and intentions, its flight level and speed, and the progress of its flight. These developments are often accompanied by advances in display technology which enhance the depiction of aircraft on ATC displays (e.g. ADS), and by advances in automated assistance for problem solving, predictions and decision making. The gathering, storage, compilation, integration,

presentation and communication of information are essential processes in ATC, and all of them can be aided by automation.

5.3.4 Air traffic is expanding worldwide. The information about aircraft is improving in quantity and quality, and must do so to allow greater numbers of aircraft to fly within the same airspace as safely as they do now. Because there are more aircraft and there is more information about each aircraft, the amount of ATC information is expanding beyond the capacities of existing systems to handle it. Yet safety and efficiency must be maintained. The problems cannot always be solved by further sectorization of airspace and the employment of more controllers because at some stage the additional liaison, coordination and communications burdens eventually outweigh other benefits. Long-term trends are for more information about each aircraft, less permissible delay in dealing with the information because aircraft are closer together, and less time for controllers to devote to each aircraft.

5.3.5 ATC information and tools for the controller are evolving through paper (flight progress strips), electronic displays, data handling (computer assistance), and automation (computer implementation). This evolutionary process has reached very different stages in different States. It has been concluded<sup>4</sup> that increased automation in ATC is inevitable. The issues are therefore about when, where and how automation should be introduced, not if it should be introduced.

Examples of automation applicable to ATC are: ATIS (which removes the need to continually read out weather data via the R/T); Mode C altitude reporting; display of the inbound or outbound sequence between Aerodrome Control and Approach/Departure control units, either by closed-circuit TV or other electronic means (which removes the need for frequent voice coordination); ground-ground datalinks between ATC units and/or centres (which also remove the need for frequent voice communications).

#### Goals of automation

5.3.6 When properly used, automation can be a great boon. It can aid efficiency, improve safety, help to prevent errors and increase reliability. The task is to ensure that this

potential is realized, by matching automated aids with human capabilities and by mutual adaptation of human and machine to take full advantage of the relative strengths of each. Depending on the type of traffic (traffic density, type of aircraft) and the ground equipment (communication and surveillance means), different types of tools can be developed to achieve these goals:

- 1) tools providing additional information without inducing any major changes in working methods, e.g. a TV network;
- 2) partial or full automation of existing non-expert tasks, e.g. transmitting control data via data link or using secondary radar (SSR) to correlate a paper flight progress strip and a radar reply by displaying the aircraft identity close to the reply;
- 3) tools which provide information that introduces a radical change in working methods, e.g. radar or automatic dependent surveillance (ADS);
- 4) automation of so-called expert tasks, using either expert systems or tools which can calculate and negotiate 4D conflict-free trajectories within an air-ground integrated system, e.g. planning of traffic flows, conflict resolution or sequencing traffic within the terminal area.

5.3.7 The influence of Human Factors considerations on the efficiency of the tools increases from type 1 to type 4. Many ATC services all over the world are already equipped with tools of types 1 to 3, and have some experience of the Human Factors issues that they introduce, but it is necessary to consider carefully the issues arising from tools of type 4. In automated systems the human will remain the key element of the system: the machine will assist the human and not the contrary. The human-machine collaboration must be studied very early in the development of any tool; if it is not, the tool may not be used as intended or not used at all, which may prejudice the efficiency or the safety of the system.<sup>5</sup>

#### Constraints

5.3.8 The human functions within the ATC system have to be described clearly. Various constraints must be overcome, including the following:

- The level of human expertise must be maintained. Even highly reliable systems can fail, and the system must remain safe, though not necessarily



efficient, in the event of failure. The controller should remain able to deal with the traffic without machine assistance even if this induces a very high workload. If the automated system shuts down, the human controller must still be able to handle the traffic, at least until all aircraft present in the sector have landed or left the area of responsibility, if necessary without the normal pilot/controller relationships.

Whenever it is possible for automated functions to revert to human functions in the event of failure, it must also be possible, while the system is functioning manually, to restore the automated functions when the failure has been repaired. Human expertise is particularly important when automating expert tasks such as conflict resolution. Expertise can be maintained only by regular practice as it is gradually lost if there are never any opportunities to use it. This introduces what might be called "the automation paradox": one other reason for automating human tasks is often to reduce, or cope with a reduction in, the number of human operators. If however (as indicated above) the human is expected to handle the situation in the event of an equipment failure, it stands to reason that the number of operators should at least be the same as in a situation without automation. Similarly, it could be argued that the amount of traffic handled in an automated ATC environment should never be higher than what can be handled without that degree of automation. Moreover, if the quality of the automated equipment is such that there are few failures only, the need to train the operators to cope with such a rare event, usually done on a simulator, becomes very high and will require additional human resources.

- The controller's mental picture of the traffic should be maintained. This picture may become less detailed and more vague if the controller becomes less actively involved in control processes and does not need to have such a detailed understanding of the air traffic in order to control it.
- The workload of the controller must remain between a minimum and a maximum threshold. Too little work induces boredom, inattention and loss of skill, and this can be dangerous in low traffic density periods. Beyond the overload threshold the controller may no longer ensure safety. Automation may induce, in certain conditions, extra tasks which generate additional

workload. There is still no satisfactory way to quantify workload in such a complex process as air traffic control. Workload may be generated by different parameters which cannot easily be aggregated, including the number of aircraft and the complexity of the traffic situation, which is not a simple function of aircraft numbers.

- Different kinds of workload are not equivalent. Time saved by reducing one kind of workload cannot always be allocated to another kind. For example, reducing the requirements for data entry does not necessarily result in more time for decision making. Tasks which require different skills and abilities may not be interchangeable. Functions that have been automated may need human verification.
- Job satisfaction must be maintained. This requires effort, challenge and use of skills. Automation may well reduce the effort required for certain tasks and the stress associated with them, but may lead to loss of job satisfaction by taking away some of the intrinsic interest of the job and the perceived control over certain functions. This is particularly important in relation to problem solving, decision making, prediction and planning (i.e. with tools of type 4).
- The controller must be able to understand and trust the automatic system. It must be reliable or at least the controller must know when it may not be — this knowledge can be an aspect of controller proficiency, e.g. to recognize under what circumstances there could be a false alarm. A tool that is not trustworthy should not be introduced: if it is, it may be ignored or misused.

Example: In several of the automated ATC systems of the 70s and 80s a crude form of Conflict Detection was built in. This often was so crude that it merely displayed all aircraft in the area that were assigned the same flight level. The method of displaying could involve a flashing label, or listing all such aircraft in tabular form in a dedicated list on a screen. It almost goes without saying that this well-intended information was ignored by most (or maybe all) air traffic controllers working with such systems.

- Task-sharing and the division of responsibilities between controllers must be unambiguous. Effective task-sharing requires rigorous planning and correct workspace design. Each controller must always know which tasks are his or her own responsibility to be done manually, which tasks are done entirely by the automated system, which tasks are done entirely by other controllers with or without the automated system, and which tasks are shared with other controllers. If planning and executive control functions are physically separated, it may be impossible for each to fulfil the main functions of the other in the event of a system failure.
- Information is transmitted from human to system and from system to human, and the human-machine coordination process must be carefully defined. It is necessary to be sure that transmitted information is acted upon by the controller and by the system, or by the pilot in the case of, for example, a data link. Furthermore, human-machine coordination does not consist only of exchanging information. There must be no interference between automated decision processes and actions taken by the controller. It is particularly difficult to achieve this when decisions may be implemented by a succession of actions and not by a single action at a fixed time.

Example: In Europe, ATFM restrictions are often caused by constraints in facilities that are remote from the airports from which flights (to which these restrictions apply) depart. It proves difficult for both controllers and pilots at relatively quiet airports to accept delays because of "busy air traffic", and subsequently the restrictions are not always adhered to.

- Although it might be quite easy for the controller to use a device such as electronic flight progress strips to inform the machine about human actions, it may be much more difficult to inform the system about future human intentions. A goal is to convey human intentions to the machine so that the machine can help the human to fulfil them.

5.3.9 It is a mistake to develop systems first and then try to devise a way for the human to use them. This is why the participation of controllers is necessary throughout the system development, from its initial specification until it

becomes operational. The human-machine interface should integrate different automated tools while improving the presentation of information to the human and communications between human and machine. It is not necessary (and may even be dangerous) to present too much information, as is always possible in highly automated systems. The aim is to present timely and relevant information when it is needed. Alternative input devices may be more suitable for some dialogues and interactions than for others.

Another example: One of the shortcomings of TCAS that was soon discovered by controllers is the fact that the earlier TCAS logic did not take into account that aircraft may be climbing and/or descending to safely assigned altitudes that may be only 1 000 feet apart. This then resulted in TCAS manoeuvres whereby the aircraft that was supposed to be 1 000 feet above the other one actually ended up passing below it. In later versions of the TCAS logic this problem was largely solved.

5.3.10 One development, with origins in intelligent knowledge-based systems and aspects of artificial intelligence and expert systems, was the introduction of forms of assistance which would aid the controller in taking decisions, solving problems, making predictions and scheduling future work. These were based on computations from automatically sensed data, and their value — and indeed their feasibility — depends on the availability of such data and the power to make these computations. These aids can handle more data, faster, more often and more reliably than a human being can. They are helpful because they allow the human controller to do more in less time. If they fail, however, the human controller taking their place will use much less information, make poorer decisions, be slower, or omit some functions. Therefore one of the problems of automation is the extent to which the human can act as a backup in the event of failure. The more helpful the automated assistance is when it is functioning normally, the more difficult it becomes for the controller to compensate for it if it fails.

5.3.11 As in any system which relies on human intervention in the event of system failure, the controller is expected to be ready to take over and maintain a safe ATC service, which implies that the controller's information must be continuously updated and that the controller must maintain a full understanding of the traffic situation. If this requirement is not met, safe reversion to more manual

forms of control may not be possible if the system fails. The human cannot be as efficient in the reverted manual mode without computer assistance, but must still remain safe.

5.3.12 One problem in ATC automation has always been the integration of different kinds of information from different sources. Flight progress strips cannot easily be laid out in the same relative positions as the radar blips, and they contain too much information to be condensed onto a label on a radar display without incurring insuperable problems of label overlap, clutter and ambiguities in interpretation. Therefore automation in ATC has often sought better ways to integrate and cross-reference the two kinds of data.

5.3.13 Paper flight progress strips do not enter any information into a computer. Wherever they are used, the controller must keep the information on them up-to-date manually, but may also have to update the corresponding information in the computer so that all the calculations based on that information and presented in the form of computer assistance are correct. If the controller has too much work, updating information may suffer because it can be postponed, though it then becomes more and more difficult to catch up. Duplication of tasks by updating the same information in two different forms seems wasteful. However, doing the same task in two forms may help to prevent errors that are typical of one form only and may also help to reinforce understanding and memory. Such issues need to be addressed so that the avoidance of duplication does not generate further problems.

Example: In an automated European ATC system (designed in the late 70s), there exist both paper and electronic flight progress strips. The original philosophy was that the paper strips would be phased out in favour of the electronic strips, but for various reasons they were both retained which implies that the controllers need to update them both, thus significantly increasing the workload. (Most controllers developed the working style to use one of the two as their "primary source" and only update the other when they are about to be relieved at their position.)

5.3.14 Various forms of automated flight progress strips are currently being tried. They seek to replace paper flight progress strips and to help the controller by minimizing task duplication, by facilitating the entry into the

system of the controller's actions and decisions, and by helping to integrate radar information and tabular information on flight progress strips. Electronic flight progress strips exemplify the aim of automation to reduce routine work and increase the time available to each controller for controlling aircraft. Progress is being made but it is proving to be a more complex problem than was originally envisaged, because paper flight progress strips fulfil a more complex range of ATC functions than was at first realized.

#### Further implications of automation

5.3.15 Different philosophies can be adopted, corresponding to different respective roles for human and machine in automated tasks. For example, if the machine is advisory, alternative solutions may be calculated and proposed to the controller in an order of preference that depends on performance criteria. The controller has the responsibility to validate the proposed solutions and to select one of them, or, if none seems correct, to devise and apply an alternative solution. The controller may also define additional constraints that the proposed solutions must fulfil: in a sequencing process in a terminal area, for instance, the controller may impose for a given aircraft an arrival time that any computed solution must comply with. In some cases, the controller may delegate the application of a solution to the machine. In an advisory role, the machine can never make a decision without controller agreement.

5.3.16 If the machine is always adequate, the controller may develop excessive trust in it and accept proposed solutions routinely without checking. However, if the machine seems inadequate in any respect, it might not be used at all. All forms of automated assistance for the controller must be highly reliable, but this can induce human complacency. Human expertise may gradually be lost and, if the machine fails, the controller may accept an inappropriate solution or become unable to formulate a satisfactory alternative.

5.3.17 This advisory role can be more suitable for planning functions which consist largely in manipulating constraints. The planning controller could define constraints that have not been taken into account by the tool and transmit them to the machine. If the machine has been suitably designed, true human and machine cooperation may be achieved, retaining human expertise. Such human-machine cooperation already occurs, e.g. in certain sequencing tools in terminal areas. **The most appropriate forms of human-machine relationships depend on the type of task which is automated and particularly on the**

**interaction between planning and executive functions.** Examples of planning functions are the allocation of flight levels in an en-route sector, inter-sector coordination, and the sequencing of aircraft into a terminal area, whereas conflict detection/resolution, monitoring and surveillance are executive functions. It may be easier to design satisfactory tools for planning controllers than it is for controllers with specific executive functions such as collision prevention.

5.3.18 In another role, the system may recognize classes of problems that it can resolve entirely. For example, in a conflict detection/resolution process it might resolve conflicts involving two aircraft but not those involving three. Tasks may be allocated either to the human or to the machine, provided that the machine can accept a problem allocated to it. The allocation process can help avoid extremes of controller workload. The successful implementation of machine roles that can resolve problems entirely requires thorough development work.

5.3.19 The automation of data can lead to Human Factors problems, since it can deprive the controller of important information about the reliability and durability of information. For example, because much information conveyed through speech cannot be expressed in digital terms, it is omitted in the automation process; thus while it may contain important *quantitative* information, it may no longer contain the *qualitative* component (confidence, hesitation, workload, urgency, etc.) needed by the controller to make the best use of it. The significance of such qualitative information must be established before it is taken away, and alternative methods of providing it may have to be adopted.

5.3.20 Whenever tasks are done automatically rather than manually, what the individual controller understands and remembers about the traffic under control can change. Acknowledgement of this before automation is introduced allows it to be compensated for if the resultant changes in understanding and memory are not acceptable. The performance of routine ATC tasks aids memory, which is not the case if these tasks are done automatically for the controller. This may be acceptable as long as it has been recognized in advance, and the system and tasks have been planned to take account of it.

### Team functions

5.3.21 Automation can affect some liveware-liveware interfaces in ATC, and as a consequence some methods of verification and supervision can change. A manual ATC system is open to inspection and checking; a supervisor or colleague can see all that a controller does, form a judgment of his or her competence, help a controller who is

overloaded, and draw attention to problems which may have remained undetected. Such functions become more difficult when there is automated assistance for problem solving, decision making and prediction, because these functions are much less immediately observable by others. It also becomes more difficult to judge the performance of the individual controller by on-the-job assessments, which are used for decisions about career development, promotion, retraining, allocation of tasks, and appropriate instructions and procedures. The introduction of computer assistance may require the reappraisal of all such factors.

5.3.22 The team roles and functions in automated systems differ from those which can be exercised in manual systems. Controllers in more automated systems are more self-sufficient and autonomous and fulfil more tasks by interacting with the machine rather than with colleagues or with pilots. There is less speech and more keying. This affects the feasibility and development of traditional team functions such as supervision, assistance, assessment and on-the-job training. If independent supervision or confirmation is still needed it may have to be provided in other forms.

5.3.23 Most forms of computer assistance seek to aid individual tasks rather than team tasks which depend on liveware-liveware interfaces. If there has been extensive automation of tasks, it may be more difficult for less experienced controllers to learn and profit from working alongside colleagues with greater experience and proficiency. Controllers may also be less able to notice a mistake by a colleague. The effects of such changes can be substantial and it may become necessary to redesign workspaces and to revise selection and training methods to restore an optimum match between the human and the machine.

5.3.24 When jobs are done by members of a closely coordinated team, a general consensus about the relative merits of individual performance can form the basis not only of professional respect and trust but also of promotions or assignments of further responsibilities. The evidence to make such decisions may, however, be changed by the automation of tasks, as may the evidence available for the assessment of individual performance. If ATC consists of accepting computer decisions, then this does not itself confirm how competent the individual controller is. Other means may have to be found to check that the controller's proficiency and professional knowledge have been maintained. ATC simulations may meet such needs, just as flight simulators do for some pilots.

*Note.— Guidelines for Team Resource Management (TRM) training development are provided in the Appendix to this Chapter.*

### Standardization

5.3.25 One issue raised by automation concerns standardization, especially in communications. Messages between controllers and pilots have standardized formats, wordings and sequences. Messages for some other communications, such as those with ground vehicles, have less complete standardization. Quite often, non-standard practices and procedures that have become entrenched among the controllers at particular ATC locations can lead to problems if they are incompatible with standardized forms of computer assistance being introduced throughout the system, either to replace human speech or to present the content of human speech in alternative forms such as visual words or synthesized auditory messages.

5.3.26 Verbal communications are safest when everyone adheres to the standard language, standard formats, standard message sequences and standard acknowledgements intended for universal use. Exceptions can lead to errors and misunderstandings, and must be discouraged. Although most current forms of automation seem rigid and inflexible, automation may in principle be able to accept more flexibility in message forms, content and language than humans can, and this raises anew the issue of how much standardization is desirable for safety.

Example: In CPDLC it is technologically feasible to have all stations use their own language when inputting, and have the automation translate this into the language of the receiving party. But this introduces new Human Factors problems, particularly when it comes to using the "free format" option from CPDLC in order to convey non-standard messages, or when working in a multinational operations room or cockpit environment. Such problems may well lead to the adoption of a common language for use in CPDLC, despite technological possibilities.

5.3.27 Automation proposes one best way to control air traffic. Yet different controllers have traditionally had some flexibility in their choice of control techniques. Alternative techniques can be broadly equivalent in terms of safety and efficiency, with none obviously superior to all others. An automated system may discourage human flexibility and impose standardization. The recommendation with present forms of automated assistance is to apply rigid

standardization and not to introduce any variations or short-cuts since these are likely to lead to a new crop of human errors or misunderstandings. This may well have an effect on air traffic controller job satisfaction.

### Human-machine interface and human error

5.3.28 The human-machine interface mainly consists of liveware-software and liveware-hardware links. Traditionally, most information has been conveyed from the machine to the human by means of visual displays and from the human to the machine by means of input devices and controls. Automation changes what is transmitted through the human-machine interface, either leading to some information not being transmitted at all or changing the format of transmitted information, such as from human speech to keyboard entry, which in turn changes the kinds of human error which are possible while entering any given message. Speech errors are often caused by phonetic confusions (sounds which are too similar to be reliably distinguished). Visual errors and misreadings can be caused by alphanumeric characters which look similar to each other, lines of data which can be mistaken for each other, blocks of data which look alike, visual labels for keys which give a misleading impression of their functions, and so on.

5.3.29 Although the kinds of human error are not all the same, their general nature can often be predicted in advance, because decisions about the choice of method of input or about the form and content of displayed information are also decisions about human error. It may not be possible to predict who will make a particular error under what circumstances, but it is possible to predict, before a change in the system is made, which human errors can no longer occur and which new kinds of error are now possible and must therefore be prevented.

Example: In a European automated ATC system designed in the 80s, when a wrong keystroke was made during entering the time in flight plan data, the flight plan would disappear to a part of the system's memory from which it could not be retrieved until the next day or later, thus causing operational problems. Such errors of course did not occur before the automated system was introduced and flight plan data was written manually on strips.

One of the most important applications of Human Factors to any form of automated assistance is this identification of new kinds of human error — especially those which might be dangerous — that can arise as a consequence of change.

## 5.4 THE SELECTION AND TRAINING OF AIR TRAFFIC CONTROLLERS

### Selection of applicants

5.4.1 Air traffic control is a demanding profession — its safety and efficiency depend on selecting those who will become most capable of doing the jobs within it. A good selection procedure eliminates unsuitable candidates at an early stage and saves training costs. Selection and training are mostly concerned with liveware, although they are influenced to some extent by all other interfaces within the SHELL model.

5.4.2 For the selection procedure to be effective, the number of applicants must exceed the number of vacancies by a substantial margin. A prerequisite for a successful selection procedure, therefore, is that ATC be viewed as a desirable profession, attracting many applicants. National publicity and positive advertising may be needed to encourage enough suitable applicants to apply. The more stringent the criteria for selection are, the larger the proportion of applicants rejected will be, and the larger the initial pool of qualified applicants must be. Given suitable applicants, the selection process is the first vital step towards producing proficient air traffic controllers. An impartial selection procedure based on Human Factors principles is essential.

5.4.3 Analysis of the ATC jobs within a particular context establishes the skills, abilities and knowledge needed to perform them and the degree of commonality among them. If there is a high degree of commonality, the same selection procedure can be used for all ATC jobs; if the commonality is low, different jobs may require different selection procedures. Various local system requirements or ATC characteristics may point to further relevant human attributes that could be included; these include the amount and patterns of traffic, the nature of the terrain, the navigational and other aids, the geographical relationships between nations, and climatic and meteorological factors.

### Tests

5.4.4 Detailed task analyses are used to identify many of the measurable human performance attributes that

contribute to success. When the relevant human attributes have been defined, tests that measure them are administered to all applicants. The tests should be standardized, and the scoring of test results must be impartial. All the attributes measured by specific tests may not be equally important to ATC, and so some test scores may be more important than others. Some tests may measure a general human ability known to be relevant to many aspects of ATC. Others may measure a more specific ability required for particular ATC tasks.

5.4.5 Numerous human abilities, measurable by standardized tests, seem to have some predictive value in the selection of controllers. These include general intelligence, spatial reasoning, abstract reasoning, arithmetical reasoning, task sharing, verbal fluency and manual dexterity. All form part of some selection procedures but none has gained universal acceptance. No single test approaches the levels of prediction that would be needed to justify total reliance on it for controller selection. Many of the most widely available personality tests have also been tried experimentally in controller selection, but none is widely used and their role has generally been limited to interpreting other measures or indicating a need to gather more evidence about an applicant.

5.4.6 The scores on some tests may be emphasized more than the scores on others. Test validation procedures can be used to suggest appropriate weighting for each test to maximize the predictive value of the whole test battery. The processes of presenting and scoring tests are becoming more automated, and it is an administrative advantage (and more objective) if impartial automated presentation and scoring can be used. Candidates must receive practice and familiarization with the automated testing procedures, however, so that their test performance is not reduced due to unfamiliarity with human-machine interfaces and computer dialogues.

5.4.7 The selection process is not static but should evolve as the jobs, tasks and equipment in ATC change. Appropriate modifications of the selection procedures may be introduced when properly conducted, and validated research has shown that additional testable human dimensions are relevant.

### Other data

5.4.8 Procedures and data other than testing are also important in the selection process. Age, medical history, eyesight, hearing, emotional stability and educational attainments are all relevant to becoming a controller. Even basic anthropometric requirements may form part of the

selection procedure — it may be impossible, for example, to accommodate exceptionally tall or short people within the ATC workspace. Some ATC workspaces, notably those in towers, may be inaccessible to disabled people. Controllers must maintain their medical fitness and therefore those who have a medical condition with a potentially unfavourable prognosis may not be selected. Drug or alcohol dependence is usually a disqualifying condition.

5.4.9 Previous knowledge of aviation, previous coaching and practice in tests similar to those used to select controllers, or previous ATC experience (for example, as a military controller or as an air traffic control assistant) might seem to be advantageous, but in fact their benefits and relevance are often disappointing, and States differ in the value they attach to such experience. One difficulty is that those with most experience are likely to be older, and those who are older than about 30 are less likely to complete ATC training successfully. Previous related experience may be a better predictor of the motivation to become a controller than of the ability to become one, and more applicable to dealing with emergencies than to routine ATC.

5.4.10 An interview helps to confirm that candidates can express themselves clearly when they speak, an essential attribute since much ATC is conducted by speech. An interview may help to reveal how well each applicant relates to other people, another essential attribute when most ATC work is not done alone but in groups and teams. The interview should be standardized, structured and demonstrably fair to all candidates in its conduct and scoring.

### Training

5.4.11 The objective of air traffic controller training is to ensure that controllers possess the required knowledge, skills and experience to perform their duties safely and efficiently, and to meet national and international standards for ATC. A controller must be able to understand and assign priorities to the relevant information, to plan ahead, to make timely and appropriate decisions, to implement them and to ensure compliance with them.

5.4.12 Training is a matter of learning, understanding and remembering. It relates what the controller already knows to the information that the system provides about current and pending traffic. It relates the information which the system presents automatically to the controller to the information which the controller must remember unaided, and it provides guidance on how human memory can be

strengthened and made more reliable. Training also relates the principles for learning and displaying ATC information to the capabilities and limitations of human information processing and understanding. The aim is to make the best use of human strengths and capabilities and to overcome or circumvent human inadequacies or limitations, particularly in relation to knowledge, skill, information processing, understanding, memory and workload.

### Training content and teaching

5.4.13 Two essential aspects of training are training content and the teaching process. With regard to training content, it is beneficial to divide the training into a series of courses or phases. These start with basic principles and practices, and progress on successful completion of each phase towards more complex aspects of ATC. This approach requires mastery of the basic principles and practices first, which helps to ensure that the later stages of training build on knowledge already acquired. Separate courses coupled with impartial assessments provide benchmarks of training progress and a form of quality assurance applicable to training. This can be particularly helpful to demonstrate that changes in the training, whether in its content or in the teaching methods such as the introduction of automated teaching aids, have been successful and beneficial.

5.4.14 It is possible to deduce from envisaged tasks what the content of training must be and what the controller must learn, only to discover that it cannot be taught or that controllers cannot learn it. In introducing changes in systems for whatever reason, therefore, it is vital to establish what new knowledge the controller must acquire and to show that it can be taught and learned. New forms of automated assistance must be teachable; if they are not, the expected benefits will not materialize and new forms of human error may arise because the automated assistance is not completely understood.

5.4.15 Various teaching methods can be employed in ATC training. Classroom instruction of principles and theories according to traditional academic methods, common in the past, is currently diminishing, partly because more active participation is favoured, partly because the relevance of theory is often disputed and partly in response to financial pressures. Instruction based on real-time simulation, some of which can be quite rudimentary, is strongly favoured as a practical means of training groups of students, and fundamental reliance on simulation training is common. In on-the-job training, a student already instructed in the principles of ATC learns its practical aspects from other controllers directly in centres and

towers. Soon there will be more self-training packages for the student to practise particular procedures and skills on a computer.

5.4.16 The task of the on-the-job coach is a demanding one. Not all controllers make good coaches, nor do all controllers want to become coaches. The controller who coaches must want to teach, must be proficient and confident in his or her own skills, and must be able to handle a traffic situation through another person, teaching skills to that person while at the same time maintaining overall command of the situation. There are principles and techniques in coaching which all who coach should be aware of so that the coaching is efficient and the standard of air traffic services is maintained. Coaching is a specialist task, one that is carried out in addition to controlling aircraft. For this reason, it will be seen that a certain amount of operational experience is necessary before a controller commences coaching.

5.4.17 There are national differences in policy on the range of ATC jobs that each individual controller should be qualified to do, which are reflected in the forms and duration of training. A knowledge of basic ATC practices and procedures is essential even in sophisticated systems, since safety may depend on such knowledge in the event of some forms of system failure. Regular additional training may be needed to maintain the controller's proficiency in the manual functions needed should the system fail. Refresher training and competency checks can be employed to ensure that the controller retains the professional knowledge and skills that are not used frequently in more automated systems but may still be needed.

5.4.18 The efficiency of learning depends on teaching methods, content and presentation of material, attributes and motivation of the student and on whether the instruction is provided by a human or a machine. It also depends on whether the instruction is theoretical or practical, general or specific. The content of what is taught, the sequence in which items are taught, the pace of teaching and the amount of reinforcement and rehearsal of taught ATC information should all be established according to known learning principles. Knowledge of results and of progress is essential for successful learning.

5.4.19 The proficient controller needs to know and understand:

- how ATC is conducted;
- the meaning of all presented information;
- the tasks to be accomplished;
- the applicable rules, procedures and instructions;
- the forms and methods of communication within the system;
- how and when to use each tool provided within the workspace;
- Human Factors considerations applicable to ATC;
- the ways in which responsibility for an aircraft is accepted and handed over from one controller to the next;
- the ways in which the work of various controllers harmonizes so that they support rather than impede each other;
- what changes or signs could denote system degradations or failures;
- aircraft performance characteristics and preferred manoeuvring;
- other influences on flight and routes, such as weather, restricted airspace, noise abatement, etc.

### Aspects of training

5.4.20 ATC is not self-evident. The typical ATC workspace contains no instructions or guidance about what it is for, what the tasks are, what the facilities are, what the displayed information actually means, what the controls and other input devices do, what constitutes success or failure or what should be done next after each task has been completed. Even in quite automated systems, ATC cannot function without human presence — it is reliant on controller intervention and will remain so for the foreseeable future. Hence the importance of identifying all that the controller needs to know and ensuring that it is known, all that the controller needs to do and ensuring that it is done, and all that the controller needs to say and ensuring that it is said clearly and correctly and at the right time. These are essential objectives of training.

5.4.21 Training should follow recommended Human Factors procedures and practices. It should be flexible enough to be adaptable to the needs of individual controllers. It should incorporate a basic understanding of Human Factors so that controllers have some insight into their own capabilities and limitations, particularly with regard to possible human errors and mistakes. Controllers should know



enough to be able to select the most appropriate aids in their workspace to improve their task performance and efficiency, especially in choosing display options.

5.4.22 Training must also ensure that the controller can cope with the workload required to control the traffic offered. This means knowing what the correct actions and procedures are in all circumstances, as well as executing them properly. The controller also needs to be able to learn how to schedule work efficiently. Training aims to teach the controller how to plan ATC and to deal successfully with any unexpected situations. Important objectives of training are to instil good skills, knowledge and habits, and to reinforce them so that they are durable and retained. They have to be maintained actively because skills degenerate, knowledge is forgotten and habits are broken if rarely used. Over-learning can be helpful in the form of extra training and practice deliberately intended to reinforce what has already been learned.

5.4.23 Training should not only encourage certain actions but discourage or prevent others. An important part of training is to break bad habits or prevent them from arising. For example, the controller must give priority to an emergency and offload other tasks. Yet the controller must never become so totally absorbed in a single problem as to fail to notice what else is happening. This might entail breaking the habit of concentrating on a single task until it has been completed and forming the new habit of frequent scanning of the radar screen or other displays to check that all is well. Training must encourage this constant scanning and alertness.

5.4.24 It is vital that the controller be capable and confident in handling high levels of traffic so that these tasks do not become excessively demanding or burdensome. Training must be related to the maximum handling capacity of the system for which the controller is being trained. Positive intervention by the controller to forestall an overload condition is just as important as the ability to keep aircraft separated. Training should also prepare the controller for conditions of underloading, when there is little traffic but the control positions must still be staffed, and the controller must be alert and able to detect any unexpected events at once.

5.4.25 Training engenders self-confidence through achieved performance. Illness or lack of well-being from whatever cause has to be remedied if its consequences render the controller inefficient or even potentially unsafe. Training which has successfully generated sound knowledge and confidence in applying that knowledge can help to sustain controllers through events which might lead to stress in others who lack such training.

### Training and system changes

5.4.26 Wherever possible, any changes made in ATC systems should allow the existing skills and knowledge of controllers to remain applicable. Any major change in the ATC system that affects what the individual controller should do or needs to know, such as a new form of automated assistance, should normally be associated with a careful redefinition of all the consequent changes in the controller's knowledge, skills and procedures. Appropriate retraining should be given **before** the controller encounters the changes while controlling real air traffic. The benefits of any changes to the ATC system that affect the controller will be gained fully only if the corresponding changes in the controller's knowledge and skills have been instilled through appropriate retraining. It should be normal for controllers to have regular refresher training, during which knowledge and skills are practised and verified and changes are introduced if needed.

5.4.27 The controller must be able to plan the air traffic control, implement the plans, make decisions, solve problems and formulate predictions. To perform the essential control tasks, the controller must understand the portrayed information, whatever form it takes. The controller must remember what forms of assistance are available and know when it is appropriate to call on each. The controller must know the right course of action in all circumstances. Human Factors addresses the thinking processes that the controller must follow and the effects of equipment changes on them. If necessary, equipment or procedures must be modified to ensure that these thinking processes do not change too much or too quickly. Whenever these thinking processes must change, appropriate controller retraining is essential. This often involves revised liveware-software links.

5.4.28 If changes are relatively minor, the aim of retraining may be to transfer what was already known. If former control procedures would be totally inappropriate in the new setting, one objective of retraining is to over-learn the new and remove any similarities between old and new, so that the controller never carries over old and inappropriate actions into the new system as a matter of habit. States introducing new systems may learn about appropriate retraining from the experience of other States that have already introduced similar systems. Another consequence of a change involving major retraining is that the training curriculum for *ab initio* ATC students will need to be revised.

5.4.29 The initial training of the new controller and the retraining of qualified controllers following system changes are not always the same. Initial training builds on

the foundation of a knowledge of the principles and practices of ATC; retraining may entail not only the learning of new knowledge and practices appropriate to the new system, but the unlearning and discarding of familiar knowledge and inappropriate practices.

### Human Factors training

5.4.30 Issues which should be addressed by specific Human Factors training for controllers include:

- learning and understanding all the rules, regulations, procedures, instructions, scheduling, planning and practices relevant to the efficient conduct of ATC;
- procedures for liaison and coordination with colleagues and pilots;
- recognition and prevention of human error;
- Threat and Error Management (TEM);
- matching the machine to the controller so that any human errors are noticed, prevented and corrected;
- verification of the training progress of each student by impartial assessments that are accepted as fair by all;
- identification of individual weaknesses that require extra training or practical experience and the provision of appropriate extra training and support to overcome these weaknesses and to correct faults and sources of error;
- acquisition of knowledge about professional attitudes and practices within ATC, which are the hallmark of professional competence;
- acceptance of the professional standards that prevail and the personal motivation always to attain and exceed those standards.

5.4.31 An aspect of controller training that traditionally has received little attention is training controllers to work as a team. Most of the training is aimed at individual controllers, be it in a simulator or during on-the-job training (OJT). It is therefore recommended to include team-processes in the ATC training curricula. A commonly accepted name for ATC team training programmes is Team Resource Management (TRM) training.

*Note.— Guidance on the development of a TRM training programme is provided in the Appendix to this Chapter.*

## 5.5 THE HUMAN ELEMENT — SPECIFIC ATTRIBUTES

### Recognition of their significance

5.5.1 The traditional emphases of Human Factors, and still perhaps the most influential ones, are on the tasks performed by each individual controller (liveware-software), on the equipment provided (liveware-hardware), and on the effects of system features on the safety and efficiency of that performance (liveware-environment). These features include the facilities and tools available, the workspace, displays, input devices, communications, forms of computer assistance and human-machine interface specifications. In air traffic control, however, many other Human Factors issues also have to be considered.

5.5.2 Some human attributes (liveware) have no apparent machine equivalent. Though they are highly pertinent, these attributes can seem irrelevant because human-machine comparisons cannot be applied to them, and they may therefore be omitted when the allocation of responsibilities to human or machine is considered. Early Human Factors studies often neglected such human attributes, because their significance was not recognized or because too little was known about them to be of practical use. However, their importance is now acknowledged and much more is known about many of them. They must no longer be ignored. They form two broad categories, depending on their origins and on how they can be changed.

5.5.3 One category of human attributes concerns the effects of ATC on those who work within it. This category therefore covers issues that can be influenced by changes in ATC procedures, environments and conditions. It includes such topics as stress, boredom, complacency and human error, which can be construed as effects on the controller of predisposing influences within the ATC system and which can therefore be changed by modifying the system.

5.5.4 The second category refers to fundamental and universal human attributes which are relatively independent of specific aspects of ATC environments and to which ATC must therefore be adapted. This category includes the needs of people at work, individual differences, human competence in specific tasks such as monitoring, and characteristics of human information processing, thinking, decision

making and remembering. ATC cannot change such attributes but must adapt to them by utilizing their advantages and circumventing their constraints. It is important to realize in resolving Human Factors problems that the direction of causality is not always the same, and that therefore the most successful solutions of particular problems may differ in kind. In both categories, the practical outcome is a mismatch between the system and the human which may have to be resolved by changes to either or both. The preferred solution depends on the category.

### The first category

#### *Stress*

5.5.5 Stress is primarily a liveware issue although any of the SHELL interfaces may be relevant to it. The incidence of stress-related illnesses among air traffic controllers compared with more general populations varies in different contexts and may not be the same in all States. It has long been contended that air traffic controllers endure excessive stress because of their occupation. This has traditionally been attributed to aspects of ATC jobs such as high task demands, time pressures or responsibilities, or inadequate equipment. More recently, it has been attributed to organizational influences or liveware-liveware interfaces such as conditions of employment, poor relationships between management and controllers, inadequate equipment, insufficient appreciation of controllers' skills, the allocation of blame for failure, excessive hours of work, inadequacies in training, disappointed career expectations or ill-informed and unfair public disparagement of ATC.

5.5.6 Two other factors may contribute to stress. One is shift work, which can disrupt sleep patterns and affect domestic and social relationships. The other is the modern lifestyle, which seems to induce stress-related symptoms in some individuals almost regardless of their jobs. A controller with stress-related symptoms may have to be removed from active duties. This can be a costly but essential remedy since the safety and efficiency of ATC must not be put at risk and problems of stress can be difficult to solve. It is much better to prevent them by good workspace, equipment and task design, sensible working hours and work patterns, supportive and understanding management, and concern for individual health and welfare. Because stress can have so many different causes, the successful prevention or reduction of stress in any given circumstances depends on the correct diagnosis of its origins.

5.5.7 The following possibilities should be examined. If the ATC demands of a particular job are excessive for nearly everyone doing that job, the demands must be

reduced by redesigning tasks and re-allocating responsibilities. If the ATC demands of a particular job have become excessive for an individual controller but not for most controllers, the individual should be transferred to a less demanding job. If conditions of employment such as the working hours or work-rest cycles rather than the ATC itself impose unavoidable stress on individual controllers, the remedy is to adjust the hours of work, the work-rest cycles or other stress-inducing conditions of employment. If the rostering and shift patterns, including occasional or regular night work, are far from optimum and lead to domestic difficulties or disrupted sleep, changes are needed in those areas.

5.5.8 Caution is required regarding the expected effects of alleviating stress. There may be compelling medical or humanitarian reasons for doing so, and cost benefits may accrue through reduced staff turnover rates and consequent lower recruitment and training costs. There may be safety or performance benefits but stress conditions are not always closely correlated with incidents and accidents, and the reasons for the alleviation of stress are not confined to performance and safety. There have been many extensive studies of stress in ATC but it remains a lively and contentious issue, not yet fully resolved.<sup>7</sup>

5.5.9 Another type of stress found in air traffic controllers is caused by having been involved in, or having witnessed, (near) fatal air traffic incidents or accidents. This stress type is often referred to as Post Traumatic Stress, or Critical Incident Stress, and may lead to serious disorders in the normal life and behavioural pattern of the person(s) involved, which could ultimately result in such person(s) leaving the ATC profession. A description of a technique to manage this type of stress is incorporated in Part 2 of this manual.

#### *Boredom*

5.5.10 Compared with stress, there has been much less work in ATC on the subject of boredom, also a liveware issue. Although it is often a problem, all its causes and consequences are not well understood. Not every common sense assumption about the causes and effects of boredom seems correct. Boredom may occur when there is little activity: the remedy is to provide more work. Boredom may occur when there is substantial activity but it has all become routine, requiring little effort and devoid of challenge and interest: the remedy is to maintain direct and active involvement in the control loop. Boredom tends to increase as skill and experience increase: the remedy is to design tasks with a hierarchy of required skills, since opportunities to exercise high-level skills can help to prevent boredom.

5.5.11 Unless there is excessive repetition of training content, boredom does not occur much during training because the workload can be controlled by matching the level of task demands with the controller's abilities. Highly skilled task performance is not immune from boredom if the skilled performance can be achieved without close attention, but attempts to relieve boredom in such circumstances can incidentally degrade highly skilled performance. Boredom is not always related to safety although common sense suggests that it must be.

Example: Many controllers may have experienced that when there were only a few aircraft in their airspace, following a particularly busy period, a loss of separation between these few aircraft (almost) occurred, whereas during the preceding busy period there were no problems at all.

5.5.12 People do not like to be bored. Time drags and they may invent tasks, procedures or diversions to make the time pass more quickly. This is not in the fundamental interests of ATC efficiency. One relevant factor is the extent to which the human is driven by the system, which may result in boredom, or has some control over it and can exercise initiatives, particularly in relation to task demands and workload. Many forms of automated assistance in ATC may have the unintended effect of increasing boredom.

5.5.13 The following recommendations may prevent or alleviate boredom:

- allow controllers as much freedom as possible to control and schedule their own workload;
- try to keep staffing levels adjusted so that there is always sufficient skilled work to do;
- design workspaces, equipment and tasks so that they promote a hierarchy of skills, and provide opportunities to use those skills;
- allow controllers to select the appropriate level of automated assistance;
- try to ensure that individuals are not alone at work, as the prevalence and consequences of boredom are often less serious among groups than individuals.

### ***Confidence and complacency***

5.5.14 Confidence and complacency are mainly live-ware issues. In a job which requires rapid problem solving and decision making, confidence in one's own abilities is essential. There is no place for indecisive persons in ATC. However, confidence can lead to over-confidence and complacency. If a job never tests an individual's limitations, every difficulty may seem familiar and every problem foreseeable — this can induce complacency. Complacency may be reduced partly by reasonably high (though not excessive) work levels, by control over the scheduling of tasks, and by training and assessment through the presentation off-line of difficult and challenging problems.

### ***Error prevention***

5.5.15 Every effort is made — in the design of systems, workspaces, human-machine interfaces, tasks and jobs; in predicting task demands; in matching skills and knowledge with jobs; and in specifying conditions of employment — to ensure that the controller will attend to the work continuously and commit as few errors as possible. The success with which this is achieved depends on adequate Human Factors contributions during the formative stages of the system planning and design. In this way, potential sources of error and inattention are detected soon enough to be removed. Most of the kinds of human error that are possible and will occur are predetermined by aspects of the system design (hardware, software, environment), which is why their general nature is often predictable. However, liveware issues usually are the main predisposing causes of each particular error. Human beings are fallible, and air traffic controllers remain fallible and subject to error no matter how experienced and proficient they become. While every effort should be made to prevent human error, it is not sensible to predicate the safety of the ATC system on the assumption that every human error can be prevented. Some errors will occur and the system must remain safe when they do, by being designed to be error-tolerant.

5.5.16 Many types of error can be predicted from task and job analyses, from characteristics of the displays, input devices, communications and human-machine interface and from ATC requirements. Sometimes humans can detect errors as they make them and correct them straightaway. Sometimes, in a team environment, colleagues can detect a controller's errors and point them out. Sometimes machines can be programmed to detect and prevent human errors by not accepting or not implementing actions that are incorrect or invalid, or by compensating automatically for their adverse consequences.

5.5.17 In speech, the main sources of error are phonetic confusions, omissions, false expectations and non-standard sequencing of items. In tabular information, one line or block of data can be mistaken for another, and characters and shapes which are insufficiently different may be misidentified. Poor labelling, misalignments between displays and controls, and lags between actions and feedback are among the sources of error in display-control relationships. The only errors that the controller can make are those permitted by the human-machine interface design.

5.5.18 Various classifications of human error in ATC have been compiled. Among the most comprehensive are those based on reported air traffic incidents, since many reports contain details of human errors that have actually occurred. An alternative approach starts with an error classification based on general evidence about characteristics of human information and thought processes, and makes distinctions, for example between errors in planning or in execution, and errors attributable to deficient knowledge, to applying the wrong rules, or to attention failures. The classes of error that could occur in ATC can be categorized according to such distinctions, which can then guide the formulation of appropriate procedures to remove them or prevent their more serious consequences.

### *Fatigue*

5.5.19 An important liveware issue is that of controllers becoming tired or fatigued, because when people are over-tired, their judgement can be impaired, and the safety and efficiency of the ATC service can be put at risk. This is unacceptable, in terms both of safety and performance and of occupational health and well-being. Controllers must not become over-tired because of excessive working hours or unreasonable task demands, and so the prevention of fatigue among controllers should exert an important influence on management decisions. Remedies include splitting jobs, adjusting staffing levels, curtailing shift lengths, improving work-rest cycles, giving further training, providing more computer assistance and installing modern equipment.

5.5.20 Staffing levels have to make provision for adequate rest breaks during each shift. The maximum recommended continuous work period without a break is normally about two hours, especially under high traffic demands. Rest should be away from the ATC environment — sitting back and trying to relax within the work environment is not the same as rest, since the controller is still on duty and may have to resume work quickly at any time. The controller must not have any ATC responsibilities

during the rest period. Even if traffic demands have been light and the controller has been under-loaded and bored, rest breaks are still needed. Under-activity is never a satisfactory substitute for a real rest break.

5.5.21 Provision for meal breaks is necessary within shifts. The maximum shift length depends on traffic demands, on whether the shift includes periods on call but not actually working, and on various logistic factors. It is not prudent to end any shift, particularly a night shift, at a time when the tired controller has to drive a car home through rush-hour traffic. Even with rest and meal breaks, more than about eight hours continuous work is not normally recommended unless the air traffic is light or intermittent. Controllers who work a statutory number of hours may prefer longer shifts in order to have longer continuous periods away from work, and rostering that results in several consecutive days off duty at regular intervals is often highly prized, but must not be achieved at the expense of severe fatigue through excessive shift lengths.

5.5.22 ATC commonly includes some shifts at night. The relevant evidence is contentious but on the whole favours rotating shift patterns rather than several consecutive nights working. Shifts should rotate later — that is, a morning shift may be followed by an afternoon shift the next day, but an afternoon shift should not be followed by a morning shift the next day. Age must be considered; older controllers may become more tired by shift work, particularly if they have to return to shift work after a spell of normal day work. Less night work may be advisable as controllers approach retirement age. While no recommendation can be applicable to all individuals, it is advisable to reallocate controllers, if necessary, to jobs that remain within their capabilities as they become older. Their greater experience may compensate for age-related deterioration in performance to some extent, but continuous sustained high levels of effort may be more tiring for them.

### **The second category**

#### *Needs at work*

5.5.23 A liveware attribute relevant to ATC is that the human has specific needs from work which are fundamentally different from those of machines. As we know, a machine can tolerate protracted idleness, but a human cannot. A machine can be employed indefinitely on routine, unskilled, undemanding, repetitive tasks, but these are not suitable for the human. A machine can monitor endlessly without becoming overtired, bored, distracted or sleepy, but a human is not an efficient monitor for long periods with

Example: In August 1993 an incident took place over a locator near Tromsø, Norway, where a loss of separation occurred between a Twin Otter and a Boeing 737. The Twin Otter was at 5 000 ft, and the B737 was cleared to 7 000 ft by ATC. When this clearance was read back the pilot said he was descending to 5 000 ft, and this error was not spotted by the controller. After a few minutes, the B737 reported over the locator at 5 000 ft. The Twin Otter crew, having passed that locator shortly before at 5 000 ft as well, immediately descended to 4 500 ft, while the controller instructed the B737 to climb to 6 000 ft. Afterwards it was determined that the horizontal distance between the two aircraft was about 4 NM during the time when vertical separation was not established.

In the subsequent investigation the following findings were recorded:

- there was a severe shortage of staff at the time of the incident;
- the controller had worked on average 40 hours of overtime per month in the three months preceding the incident;
- the week before the incident the controller worked seven shifts; two of these were overtime shifts, and two of them were nightshifts;
- the controller was at the end of a period of eleven days at work without any days off;
- there was no relief for the two controllers in the tower (working TWR and APP control, respectively); consequently controllers had to eat their meals at their work stations during quiet periods;
- the tower cab was too small: originally designed for one controller plus one assistant, it often was occupied by a crew of three controllers, one assistant and two trainees;
- flight planning and pre-flight briefing took place in the tower;
- controllers at Tromsø were reluctant to refuse overtime work, as that would increase the burden on their colleagues.

The Investigation Board made the following five recommendations to the Norwegian CAA:

- intensify efforts to increase staffing permanently at Tromsø TWR/APP;
- take action to reduce the use of overtime among controllers;
- improve the physical working conditions for the personnel at Tromsø TWR/APP;
- consider establishing a concept for control rooms in the air traffic services similar to the term "sterile" used during aircraft operations;
- establish rules for controllers enabling them to assess their own physical and mental health prior to the provision of air traffic control service.

Source: The Controller/June 1995

little happening. A machine seems indifferent to other machines whereas the controller seeks the good opinion and respect of colleagues and others.

5.5.24 Human controllers have job and career expectations; they need to be able to plan their futures. They can become disillusioned if their actual career or their career prospects are below their expectations, even though their expectations may seem unrealistic to others. ATC jobs now and in the future should recognize human aspirations for job satisfaction. Among the most effective advocates of ATC as a profession are the controllers themselves, provided that their jobs seem satisfying and meet basic human needs at work. If ATC is to thrive when it becomes more automated, controllers' attitudes towards its automated forms should be as favourable as they are towards its more manual forms.

### Attitudes

5.5.25 Performance can be influenced by conditions of employment, by professional ethos, norms and standards, by morale through working as a member of a professional team, and by the attitudes of controllers, all aspects of liveware. Controllers form attitudes to:

- the ATC system itself;
- their profession;
- those for whom they work, such as management or employers;
- those who can influence their conditions of employment;
- colleagues;
- pilots;
- those who design ATC systems and facilities;
- those who service and maintain the system;
- the equipment and facilities with which they are provided.

Attitudes to equipment are influenced by its suitability to the tasks, how error-free it is, and how modern it is. The provision of up-to-date equipment is often interpreted as a symbol of the value and status accorded to ATC.

5.5.26 Some further influences affect the whole ATC community. These include attitudes towards and relations with:

- the international ATC community;
- international authorities concerned with standards and practices;
- other professions with which controllers compare their own;
- the aviation community;
- passengers;
- the general public;
- those in positions of power and influence;
- the media.

5.5.27 Controllers' attitudes towards these further influences depend on whether they perceive them as supportive to ATC or not. Wherever possible, management should seek to promote favourable attitudes to air traffic controllers on the part of these influences and vice versa. It is unhelpful if, for example, ATC is blamed for delays or aggravation for which it is not directly responsible.

### Individual differences

5.5.28 The large individual differences between people are an aspect of liveware and a primary concern of selection procedures. These differences include medical differences, differences in physique, in abilities, in aptitudes and perhaps in personality. A group of successful candidates can be expected to differ less than the original group of applicants from which they were selected. The training processes then seek to reduce further the remaining individual differences among those selected. In this way, the safety and efficiency of the ATC service do not depend significantly on which individual controllers are on operational duty at a given time, although their way of achieving such safety and efficiency may differ considerably from that of another group of controllers from the same facility ("group culture").

5.5.29 Selection and training both have the effect of reducing individual differences. Yet some differences remain, and they can be very beneficial. They can form the basis for career development and for allocating controllers to different jobs. In the future, automation may adapt more

to the individual controller by making the best use of individual strengths and compensating for individual weaknesses, whereas the current practice is to discount individual differences and to build on general human strengths and circumvent general human weaknesses. This trend may become particularly important if a shortage of available applicants forces the selection of candidates who initially have more varied potential abilities and backgrounds.

#### A general Human Factors view

5.5.30 ATC has to take account of the basic cognitive capabilities of people, how they think, how they decide, how they understand and how they remember. Jobs and tasks must be designed within these capabilities and training must be devised to maximize them. People need to be able to use their cognitive capacities well and sensibly, in ways which they recognize as worthwhile and not demeaning.

5.5.31 The conditions of employment of controllers vary. There is a need to periodically review and make recommendations about the total hours of work, rostering and shift patterns, and the maximum permissible period of continuous work with no rest break. The designs of the workspace must not induce any occupational health hazards such as visual or postural difficulties during the performance of ATC tasks. There must always be provision for the early retirement from operational duties of individual controllers on medical grounds.

5.5.32 ATC is dynamic and expanding. The future rate of expansion is difficult to predict, being subject to factors totally beyond the direct influence of ATC, such as global and national economic conditions, the availability and cost of fuel, and the travelling public's perception of how safe it is to fly. Nevertheless, all projections expect air traffic to increase so substantially in the longer term that most existing ATC systems will have to be replaced, extended or further developed because they were never designed to handle so much traffic.

5.5.33 The applicability to ATC of technological innovations such as satellite-derived information, data links, colour coding, artificial intelligence and direct voice input has to be appraised, to assess their helpfulness and their optimum forms in relation to ATC. It is necessary to identify all the Human Factors consequences of such changes, and to resolve the associated problems not only of display, control, integration, interfaces, communications, understanding and memory, but also of team roles, attitudes, norms and ethos.

## LIST OF REFERENCES

### Human Factors Source References

- Ackermann, D. & Tauber, M.J. (eds) (1990) *Mental Models and Human-Computer Interaction*. Amsterdam: Elsevier.
- Adams, J.A. (1989) *Human Factors Engineering*. New York: Macmillan.
- Baecker, R.M. & Buxton, W.A.S. (eds) (1987) *Readings in Human-Computer Interaction: A Multi-disciplinary Approach* Los Altos, CA: Morgan Kaufman.
- Bainbridge, L. (1987) *Ironies of Automation*. In: Rasmussen, J., Duncan, K. & Leplat, J. (eds) *New Technology and Human Error*. Chichester, England: Wiley. 271-283.
- Bainbridge, L. & Ruiz Quintanilla, S.A. (eds) (1989) *Developing Skills with Information Technology*. Chichester, England: Wiley.
- Boff, K.R. & Lincoln, J.E. (eds) (1988) *Engineering Data Compendium: Human Perception and Performance*, 3 volumes and *User's Guide*. Ohio: Harry G. Armstrong Aerospace Medical Research Laboratory.
- Booth, P. (1989) *An Introduction to Human-Computer Interaction*. Hove, England: Erlbaum.
- Bradley, G. (1989) *Computers and the Psychosocial Work Environment*. London: Taylor and Francis.
- Burgess, J.H. (1986) *Designing for Humans: The Human Factor in Engineering*. Princeton, NJ: Petrocelli.
- Burgess, J.H. (1989) *Human Factors in Industrial Design: The Designer's Companion*. Blue Ridge Summit, Pennsylvania: TAB.
- Card, S.K., Moran, T.P. & Newell, A. (1983) *The Psychology of Human-Computer Interaction*. Hillsdale, NJ: Erlbaum.
- Cooper, C.L. & Payne, R. (eds) (1988) *Causes, Coping and Consequences of Stress at Work*. Chichester, England: Wiley.
- Costa, G., Cesana, G.C., Kogi, K. & Wedderburn, A. (eds) (1990) *Shiftwork: Health, Sleep and Performance*. Frankfurt, Germany: Verlag Peter Lang.
- Davies, D.R., Matthews, G. & Wong, C.S.K. (1991) Ageing and Work, In: Cooper, C.L. and Robertson, I.T. (eds) *International Review of Industrial and Organizational Psychology*. 6, 149-212. Chichester, England: Wiley.
- Damos, D. (ed) (1991) *Multiple Task performance* London: Taylor & Francis.
- Diaper, D. (ed) (1989) *Task Analysis for Human-Computer Interaction*. Chichester, England: Ellis Horwood.
- Durrett, H.J. (ed) (1987) *Color and the Computer*. Orlando, FL: Academic Press.
- Eason, K. (1988) *Information Technology and Organizational Change* London; Taylor & Francis.



- Ernsting, J. & King, P. (eds) (1988) *Aviation Medicine*. London: Butterworths.
- Farmer, E. (ed) (1991) *Human Resource Management in Aviation*. Aldershot, England: Avebury Technical.
- Farmer, E. (ed) (1991) *Stress and Error in Aviation*. Aldershot, England: Avebury Technical.
- Frankenhaeuser, M. & Johansson, G. (1986) Stress at Work: Psychobiological and Psychosocial Aspects. *Applied Psychology: An International Review*, 35, 287-299.
- Fraser, T.M. (1989) *The Worker at Work: A Textbook Concerned with Men and Women in the Workplace*. London: Taylor and Francis.
- Grandjean, E. (1988) *Fitting the Task to the Man*. London: Taylor and Francis.
- Hancock, P.A. & Warm, J.S. (1989) A Dynamic Model of Stress and Sustained Attention. *Human Factors*, 31, 519-537.
- Hockey, G.R.J. (ed) (1983) *Stress and Fatigue in Human Performance*. Chichester, England: Wiley.
- Holding, D.H. (ed) (1989) *Human Skills*. Chichester, England: Wiley.
- Hopkin, V.D. (1982) *Psychology and Aviation*. In: Canter S. & Canter, D. (eds) *Psychology in Practice*. Chichester, England: Wiley. 233-248.
- Hunt, R.W.G. (1991) *Measuring Colour*. Hemel Hempstead, England: Ellis Horwood. (Simon and Schuster International).
- Ivergard, T. (1989) *Handbook of Control Room Design and Ergonomics*. London: Taylor and Francis.
- Jensen, R.S. (ed) (1989) *Aviation Psychology*. Aldershot, England: Gower.
- Landau K. & Rohmert, W. (eds) (1989) *Recent Developments in Job Analysis*. London: Taylor and Francis.
- Loeb, M. (1986) *Noise and Human Efficiency*. Chichester, England: Wiley.
- Long, J. & Whitefield, A. (eds) (1989) *Cognitive Ergonomics and Human-Computer Interaction*. Cambridge: Cambridge University Press.
- Megaw, E.D. (1991) Ergonomics: Trends and Influences. In: Cooper, C.L. & Robertson, I.T. (eds). *International Review of Industrial and Organizational Psychology*, 6, 109-148.
- Monk, T. & Folkard, S. (1992) *Making Shiftwork Tolerable: A Practical Guide*. London: Taylor and Francis.
- Muir, B.M. (1987) Trust between humans and machines, and the design of decision aids. *International Journal of Man-Machine Studies*, 27, 527-539.
- Norman, D.A. (1988) *The Psychology of Everyday Things*. New York: Basic Books.
- Norman, D.A. & Draper, S.W. (eds) (1986) *User Centered System Design*. Hillsdale, NJ: Erlbaum.
- Noro K. & Imada, A.S. (1991) *Participatory Ergonomics*. London: Taylor & Francis.
- Perrow, C. (1984) *Normal Accidents: Living with High-risk Technologies*. New York: Basic Books.
- Pheasant, S. (1986) *Bodyspace: Anthropometry, Ergonomics and Design*. London: Taylor and Francis.
- Rasmussen, J., Duncan, K. & Leplat, J. (eds) (1987) *New Technology and Human Error*. Chichester, England: Wiley.
- Reason, J.T. (1990) *Human Error*. Cambridge: Cambridge University Press.
- Reason, J.T. (1997) *Managing the Risks of Organizational Accidents*. Ashgate Publishing Ltd., Aldershot, Hants, UK.
- Reilly, R. (ed) (1987) *Communication Failure in Dialogue and Discourse: Detection and Repair Processes*. Amsterdam: North-Holland.
- Rodahl, K. (1989) *The Physiology of Work*. London: Taylor and Francis.
- Salvendy, G. (ed) (1987) *Handbook of Human Factors*. New York: Wiley.
- Sauter, S.L., Hurrell, J.L. & Cooper, C.L. (eds) (1989) *Job Control and Worker Health*. Chichester, England: Wiley.
- Sayers, B.A. (ed) (1988) *Human Factors and Decision Making: Their Influence on Safety and Reliability*. London: Elsevier Applied Science.
- Sen, R.N. (1984) Applications of Ergonomics to Industrially Developing Countries. *Ergonomics*, 27, 1021-1032.
- Senders, J.W. & Moray, N.P. (1991) *Human Errors: Their Causes, Prediction and Reduction*. Hillsdale, NJ: Erlbaum.
- Sher, S. (ed) (1988) *Input Devices*. Boston, MA: Academic Press.
- Shneiderman, B. (1987) *Designing the User Interface: Strategies for Effective Human-Computer Interaction*. Reading, MA: Addison-Wesley.
- Shorrock, B. (1988) *System Design and HCI - A Practical Handbook*. Wilmslow: Sigma Press.
- Singleton, W.T. (1989) *The Mind at Work: Psychological Ergonomics*. Cambridge: Cambridge University Press.
- Singleton, W.T. & Hovden, J. (eds) (1987) *Risk and Decisions*. Chichester, England: Wiley.
- Spector, P.E., Brannick, M.T. & Coovert, M.D. (1989) *Job Analysis*. In: Cooper, C.L. & Robertson, I.T. (eds) *International Review of Industrial and Organizational Psychology*, 4, 281-328.
- Suchman, L.A. 1987) *Plans and Situated Actions: The Problem of Human-Machine Communication*. Cambridge: Cambridge University Press.
- Sutcliffe, A. (1988) *Human-Computer Interaction*. Basingstoke, England: Macmillan Education.
- Travis, D. (1991) *Effective Color Displays: Theory and Practice*. London: Academic Press.
- US Department of Defense (1989) *Human Engineering Design Criteria for Military Systems, Equipment and*

*Facilities: Military Standard MIL-STD-1472D*. Philadelphia: Naval Publications and Forms Center.

- Weir, G. & Alty, J. (eds) (1990) *Human Computer Interaction and Complex Systems*. London: Academic Press.
- Wiener, E.L. & Nagel, D.C. (eds) (1988) *Human Factors in Aviation*. San Diego: Academic Press.
- Williams, T.A. (1988) *Computers, Work and Health: A Socio-Technical Approach*. London: Taylor and Francis.
- Wilson, J.R. & Corlett, E.N. (eds) (1990) *Evaluation of Human Work: A Practical Ergonomics Methodology*. London: Taylor and Francis.
- Wise, J.A. & Debons, A. (eds) (1987) *Information Systems: Failure Analysis*. Berlin: Springer-Verlag.
- Wisner, A. (1985) Ergonomics in Industrially Developing Countries. *Ergonomics*, 28, 1213-1224.
- Wisner, A. (1989) Variety of Physical Characteristics in Industrially Developing Countries — Ergonomic Consequences. *International Journal of Industrial Ergonomics*, 4, 117-138.
- Woodson, W.E. (1987) *Human Factors Reference Guide for Electronics and Computer Professionals*. New York: McGraw-Hill.

#### Air Traffic Control Source References

- Benoit, A. (ed) (1986) *Efficient Conduct of Individual Flights and Air Traffic, or Optimum Utilization of Modern Technology for the Overall Benefit of Civil and Military Airspace Users*. Paris: NATO AGARD Conference Proceedings No. 410.
- Brenlove, M.S. (1987) *The Air Traffic System*. Ames, Iowa: Iowa State University Press.
- Buck, R.O. (1984) *Aviation: International Air Traffic Control*. New York: Macmillan Publishing.
- Duke, G. (1986) *Air Traffic Control*. Shepperton, England: Ian Allan.
- Federal Aviation Administration (1988) *National Airspace System Plan*. Washington DC: Federal Aviation Administration, US Government Printing Office.
- Field, A. (1985) *International Air Traffic Control — Management of the World's Airspace*. Oxford, England: Pergamon.
- Graves, D. (1989) *United Kingdom Air Traffic Control*. Shrewsbury, England: Airlife Publishing.
- National Research Council (1997) *Flight to the Future — Human Factors in Air Traffic Control*. National Academy Press, Washington D.C., USA.
- National Research Council (1998) *The Future of Air Traffic Control — Human Operators and Automation*. National Academy Press, Washington D.C., USA.

#### General Human Factors References on Air Traffic Control

- American Institute of Aeronautics and Astronautics (1991) *Challenges in Aviation Human Factors: The National Plan*, Washington DC, AIAA.
- Fitts, P.M. (ed) (1951) *Human Engineering for an Effective Air-Navigation and Traffic-Control System*. Washington DC: National Research Council.
- Hopkin, V.D. (1988) *Air Traffic Control*. In: Wiener, E.L. & Nagel, D.C. (eds) *Human Factors in Aviation*. San Diego: Academic Press. 639-663.
- Hopkin, V.D. (1995) *Human Factors in Air Traffic Control*. Taylor & Francis, London, UK.
- Isaac, A. & Ruitenbergh, B. (1999) *Air Traffic Control: Human Performance Factors*. Ashgate Publishing Ltd., Aldershot, Hants, UK.
- Lenorovitz, D.R. & Phillips, M.D. (1987) *Human Factors Requirements Engineering for Air Traffic Control Systems*. In: Salvendy, G. (ed) *Handbook of Human Factors*. New York: Wiley. 1771-1789.
- Pozesky, M.T. (Ed) (1989) *Special Issue on Air Traffic Control*. Proceedings of the IEEE, 77, 11, 1603-1775.

#### Specific Human Factors References on Air Traffic Control

- Cardosi, K.M. & Murphy, E.D. (eds.) (1995) *Human Factors in the Design and Evaluation of Air Traffic Control Systems*. US Department of Transportation, FAA, Washington D.C., USA.
- Costa, G. (1991) *Shiftwork and Circadian Variations of Vigilance and Performance*. In: Wise, J.A., Hopkin, V.D. & Smith, M.L. (eds) *Automation and Systems Issues in Air Traffic Control*. Berlin: Springer-Verlag, 267-280.
- Costa, G. (1995) *Occupational Stress and Stress Prevention in Air Traffic Control*. CONDI/T/WP.6/1995, International Labour Office, Geneva, Switzerland.
- Della Rocco, P.S., Manning, C.A. & Wing H. (1990) *Selection of Air Traffic Controllers for Automated Systems: Applications from Current Research*. Washington DC: Federal Aviation Administration, Office of Aviation Medicine, DOT/FAA/AM-90/13.
- Eurocontrol (1996) *Guidelines for Developing and Implementing Team Resource Management HUM.ET1.ST10.DEL-01*, Eurocontrol, Brussels, Belgium. (Available at [www.eurocontrol.int/humanfactors/publ.html](http://www.eurocontrol.int/humanfactors/publ.html))
- Hancock, P.A. (1991) *The Aims of Human Factors and their Application to Issues in Automation and Air Traffic Control*. In: Wise, J.A., Hopkin, V.D. & Smith, M.L. (eds) *Automation and Systems Issues in Air Traffic Control*. Berlin: Springer-Verlag, 187-199.

- Hopkin, V.D. (1985) *Fitting Machines to People in Air Traffic Control Automation*. In: Proceedings of Seminar on Informatics in Air Traffic Control, Capri, Italy, 147-163.
- Hopkin, V.D. (1989) Implications of Automation on Air Traffic Control. In: R.S. Jensen (ed) *Aviation Psychology*. Aldershot, England: Gower Technical. 96-108.
- Hopkin, V.D. (1989) Man-Machine Interface Problems in Designing Air traffic Control Systems. *Special Issue on Air Traffic Control*. Proceedings of the IEEE. 77, 11, 1634-1642.
- Hopkin, V.D. (1990) Operational Evaluation. In: Life M.A., Narborough-Hall, C.S. and Hamilton, W.I. (eds) *Simulation and the User Interface*. London: Taylor and Francis. 73-84.
- Hopkin, V.D. (1991) *The Impact of Automation on Air Traffic Control Systems*. In: Wise, J.A., Hopkin, V.D. & Smith, M.L. (eds) *Automation and Systems Issues in Air Traffic Control*. Berlin: Springer-Verlag, 3-19.
- ICAO (2000) *Human Factors Guidelines for Air Traffic Management Systems*. Doc. 9758, ICAO, Montreal, Canada.
- Kaplan, M. (1991) *Issues in Cultural Ergonomics*. In: Wise, J.A., Hopkin, V.D. & Smith, M.L. (eds) *Automation and Systems Issues in Air Traffic Control*. Berlin: Springer-Verlag, 381-393.
- Lenorovitz, D.R. & Phillips, M.D. (1987) *Human Factors Requirements Engineering for Air Traffic Control Systems*. In: Salvendy, G. (ed) *Handbook of Human Factors*. New York: Wiley, 1771-1789.
- Manning, C.A., Kegg, P.S. & Collins, W.E. (1989) *Selection and Screening Programmes for Air Traffic Control Specialists*. In: Jensen, R.S. (ed) *Aviation Psychology — A Contribution to the Technical Symposium*. Aldershot, England: Gower Technical Press Ltd. 321-341.
- Melton, C.E. (1982) *Physiological Stress in Air Traffic Controllers: A Review*. Washington, DC: FAA Office of Aviation Medicine. Report FAA-AM-82-17.
- Sells, S.B., Dailey, J.T. & Pickrel, E.W. (eds) (1984) *Selection of Air Traffic Controllers*. Washington DC: Federal Aviation Administration, Office of Aviation Medicine, FAA-AM-84-2.
- Stager, P. (1991) *Error Models for Operating Irregularities: Implications for Automation*. In: Wise, J.A., Hopkin, V.D. & Smith, M.L. (eds) *Automation and Systems Issues in Air Traffic Control*. Berlin: Springer-Verlag, 321-338.
- Tattersall, A., Farmer, E. & Belyavin, A. (1991) *Stress and Workload Management in Air Traffic Control*. In: Wise, J.A., Hopkin, V.D. & Smith, M.L. (eds) *Automation and Systems Issues in Air Traffic Control*. Berlin: Springer-Verlag, 255-266.
- Whitfield, D. & Jackson, A. (1982) *The Air Traffic Controller's "Picture" as an Example of a Mental Model*. In: Johannsen, G. & Rijnsdorp, J.E. (eds) *Analysis Design and Evaluation of Man-Machine Systems*. Dusseldorf, Germany: International Federation of Automatic Control, 45-52.
- Wing, H. & Manning, C.A. (eds) (1991) *Selection of Air Traffic Controllers: Complexity, Requirements, and Public Interest*. Washington DC: Federal Aviation Administration, Office of Aviation Medicine. DOT/FAA/AM-91/9.
- Wise, J.A., Hopkin, V.D. & Smith, M.L. (eds) (1991) *Automation and Systems Issues in Air Traffic Control*. NATO Advanced Science Institutes Series F: Computer and Systems Sciences, V. 73. Berlin: Springer-Verlag.
-

# Appendix to Chapter 5

## GUIDELINES FOR TEAM RESOURCE MANAGEMENT (TRM) TRAINING DEVELOPMENT

### INTRODUCTION

1. After the successful introduction of Crew Resource Management (CRM) training programmes for aircrew over the last two decades of the 20th century, the feasibility of exporting this type of training to other aviation domains (e.g. maintenance, air traffic services) was considered. This appendix will explore the development of advanced human performance training programmes for air traffic service (ATS).

2. First, information is provided on the historical background of human performance training programmes in ATS. The main points from Part 2, Chapter 2, of the Manual are presented in condensed form. Next, Team Resource Management (TRM) is introduced as a prerequisite for Threat and Error Management (TEM), and guidelines are provided for the introduction of TRM and TEM training in an ATS organization. References to related information sources are provided at the end of the appendix.

3. To put this appendix in context it should be mentioned that the advanced training described here is aimed at already qualified ATS staff, whereas the basic training described in Part 2, Chapter 1, of this Manual is intended for the pre-qualification level (i.e. during initial training). Notwithstanding this distinction, ATS training establishments are encouraged to introduce elements from the advanced section into their initial training programmes where possible, thus better preparing newly qualified staff for the environment in which they will eventually work.

### BACKGROUND

4. In the mid-1990s several initiatives were started by various ATS providers to develop a CRM-like programme that would be suitable for use in the ATS environment. The name for these programmes, that has become accepted to distinguish them from CRM for airlines, is Team Resource Management (TRM) training.

5. In developing and implementing this kind of training, and similar to the discovery by airlines that a CRM programme suitable for one airline could not be simply used by another, it was soon found that existing CRM training programmes could not be simply transferred to the ATS environment. While the philosophies and principles of the CRM programmes were found to be generally valid for the ATS environment, the format and content of the programmes would require adaptation in order to make them meaningful for, and acceptable to, the ATS community.

6. Whilst acknowledging the value and significance of the developmental work on TRM done in other ATS organizations (e.g. in Australia and Canada), this appendix builds mainly on the TRM version as developed by the European Organisation for the Safety of Air Navigation (Eurocontrol) as part of the European Air Traffic Management Programme (EATMP). However, this appendix provides a perspective in which TRM will enable operational personnel to manage threats and errors. This perspective is similar to that on CRM as discussed in the first part of this chapter.

### Crew Resource Management (CRM) — a summary

7. For the benefit of those who have not read Part 2, Chapter 2, the main points are presented herein in condensed form. The numbers at the end of a bullet point refer to the corresponding paragraphs of Part 2, Chapter 2.

- CRM is a widely implemented strategy in the aviation community that acts as a training counter-measure to human error. Traditionally, CRM has been defined as the utilization of all resources available to the crew to manage human error. From the onset, it is important to place CRM within the scope of Human Factors training: CRM is but **one** practical application of Human Factors training, concerned with supporting crew responses to threats and errors that manifest in the operating

environment. The objective of CRM training is to contribute to incident and accident prevention. (2.1.9 - 10)

- CRM has evolved through several “generations”, each of which has its own characteristics. An unintended consequence of the broadening of the scope of CRM training, however, is that the original focus, i.e. the management of human error, became diluted. (2.1.12 -21)
- It seems that in the process of teaching people *how* to work together, the industry may have lost sight of *why* working together well is important. The overarching rationale for CRM — supporting crew responses to threats and errors that manifest in the operating environment — has apparently been lost. What should be advocated is a more sharply defined justification that is accompanied by proactive organizational support. (2.1.27 – 32)
- Underlying the fifth generation of CRM is the premise that human error is ubiquitous and inevitable, and is also a valuable source of information. If error is inevitable, CRM can be seen as a set of error countermeasures with three lines of defence. The first is the avoidance of error. The second is trapping incipient errors after they are committed. The third is mitigating the consequences of those errors that occur and are not trapped. The same set of CRM error countermeasures apply to each situation, the difference being in the time of detection. (2.1.33)
- To gain acceptance of the error management approach, organizations must communicate their formal understanding that errors will occur, and they should adopt a non-punitive approach to errors. (This does not imply that any organization should accept wilful violations of its rules or procedures.) In addition to “accepting” errors, organizations need to take steps to identify the nature and sources of errors in their operations. (2.1.34)
- Fifth generation CRM aims to present errors as normal and to develop strategies for managing errors. Its basis should be formal instruction in the limitations of human performance. This includes communicating the nature of errors as well as empirical findings demonstrating the deleterious effects of stressors such as fatigue, work overload and emergencies. These topics, of course, require

formal instruction, indicating that CRM should continue to have its own place in initial and recurrent training. (2.1.35)

- At the same time that error management becomes the primary focus of CRM training, training should be introduced for instructors and evaluators in the recognition and reinforcement of error management. This training should stress the fact that effective error management is the hallmark of effective crew performance and that well-managed errors are indicators of effective performance. (2.1.37)
- CRM is not and never will be the mechanism to eliminate error and ensure safety in a high-risk endeavour such as aviation. Error is an inevitable result of the natural limitations of human performance and the function of complex systems. CRM is one of an array of tools that organizations can use to manage human error. (2.1.40)
- The fundamental purpose of CRM training is to improve flight safety through the effective use of error management strategies in individual as well as systemic areas of influence. Hence, it is only reasonable to refocus CRM as threat and error management (TEM) training. (2.1.44)

#### **Team Resource Management (TRM) and Threat and Error Management (TEM)**

8. The development of TRM training programmes for ATM coincided with the broadening of the scope of CRM training in what is now known as the third generation of CRM. Just as in hindsight it was concluded that by broadening the scope of CRM the focus on the original purpose of the training (i.e. error management) became diluted, TRM training programmes appear to have focused on “team work” as a goal rather than as a means for error management. It is therefore necessary to refocus TRM training as an enabler for threat and error management (TEM). Figure 5-App-1 shows the relationship between TRM skills and TEM.

9. For a better understanding of TEM principles it is highly recommended to read section 2.3 “Threat and Error Management (TEM) Training” from Part 2, Chapter 2.

#### **Threat and Error Management (TEM) in Air Traffic Control (ATC)**

10. One of the premises in TEM is that perspectives on errors as portrayed by traditional views on human error

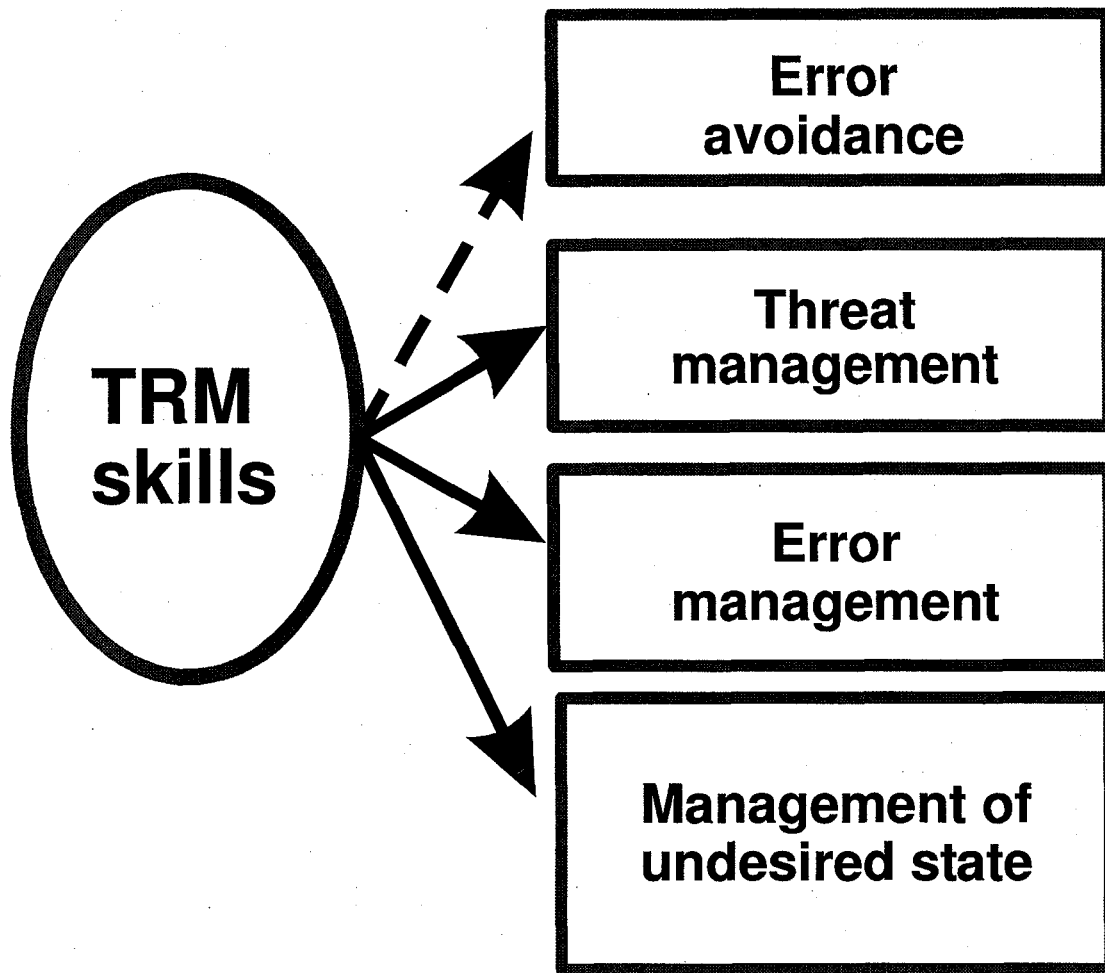

Figure 5-App-1. TEM — An operational training tool

do not properly reflect the realities of operational contexts. Operational personnel in ultra-safe industries, of which aviation is a perfect example, do not make decisions choosing between a good and a bad outcome. Operational personnel make decisions that seem best in the light of their training, experience and understanding of the situation. They make sense of the operational context in which they are immersed, based upon cues and clues provided by the context of the situation. Only afterwards, when the result of such assessment is known (the outcome), is it possible to suggest – with the benefit of hindsight – that a different assessment would probably have resulted in a more desirable outcome.

11. In case the outcome was an undesired one, the assessment leading to that outcome is usually classified as an “error”. This can only be done when the outcome is known (which was not the case when the assessment took place) and when additional information about the context of the situation is available (which was not available to the people attempting to make sense of the prevailing operational conditions) that suggests another course of action than the one taken.

12. The question that begs answering thus becomes: “why was the additional information now available not available to the people at the time of the event?” Among

the various answers, one that is relevant to TEM is “because they may not have been trained to be on the lookout for precursors of error”, i.e. they were not actively engaged in the identification of threats. Threats are such an integral part of the operational context that they are routinely sidelined. Through extended exposure to a threat-rich environment, operational personnel have learned to live with threats as normal components of operational contexts. Yet, for all the existing “normalization” of threats, mismanaged threats continue to hold their full safety-damaging potential.

13. Under TEM, a threat is not a problem as such in itself, but it could develop into one if not managed properly. As can be seen in the chart in Figure 5-App-2, not every threat leads to an error, and not every error leads to an undesired state, yet the potential is there and so should be recognized. For example, visitors in an ATC operations room are a “threat”: their presence in itself is not a dangerous situation, but if the visitors engage in discussions with the ATC crew or otherwise distract them, they might lead the controller to make an error. Recognizing this situation as a threat will enable the controllers to manage it accordingly, thereby minimizing or preventing any distraction and thus not allowing the safety margins in the operational context to be reduced.

#### **Team Resource Management (TRM)**

14. TRM is an ATS strategy applied as a training countermeasure to human error. It is defined as: “To make optimal use of all available resources – people, equipment and information – to enhance the safety and efficiency of Air Traffic Services”.

15. The main benefits of TRM are considered to be:
- enhanced Threat and Error Management capabilities;
  - enhanced continuity and stability of team work;
  - enhanced task efficiency;
  - enhanced sense of working as a part of a larger and more efficient team;
  - increased job satisfaction; and
  - improved use of staff resources.

As a minimum, TRM training should cover the elements depicted in Figure 5-App-3.

#### **Introducing TRM**

##### *Preparing the grounds*

16. The role of management support in the success of team training initiatives like TRM cannot be overestimated. It is important that TRM not be viewed as a cosmetic and expensive “add-on” to existing training, but rather as an integral part of the training structure and culture within the organization. A number of practical and relatively inexpensive methods exist by which TRM can be integrated into a company. These include underlining the importance of good teamwork at every meeting; using existing members of staff and training them as “coaches” and advocates of team training. In the context of ATC, supervisors, team leaders and those responsible for coaching trainees would seem to be likely candidates for these roles.

17. Other methods are utilizing and adapting existing programmes to address problems where teamwork skills have been shown to be inadequate, and being prepared to deal with instances of poor team performance with the same level of concern as would be shown for any other examples of sub-optimum performance likely to affect safety and efficiency.

18. While safety remains of paramount importance, management also has to take into account the relative benefits and costs of any innovation. As with many safety-related issues, it is difficult to place a monetary value on the benefits to be gained from the implementation of TRM except perhaps to compare it with the potential cost, in human and monetary terms, of an incident or accident brought about by poor teamwork.

19. In addition to making management aware of the benefits of good team-working, it is essential to convince the operational staff that TRM has something to offer them in their daily work. Controllers, for example, realize the importance of good communication in a task which essentially depends for its safe execution on the quality and accuracy of the information which is transferred and the manner in which the various team members communicate. However, the need to be able to accept suggestions from colleagues, to give and receive constructive criticism, and to view the whole task as an exercise in team performance as well as individual skill, is perhaps less well understood.

20. Much of the success of the implementation process depends on the manner in which TRM information and concepts are conveyed. The credibility of any course will depend on the relevance of the information provided to the participants’ everyday working lives. However, in the effort

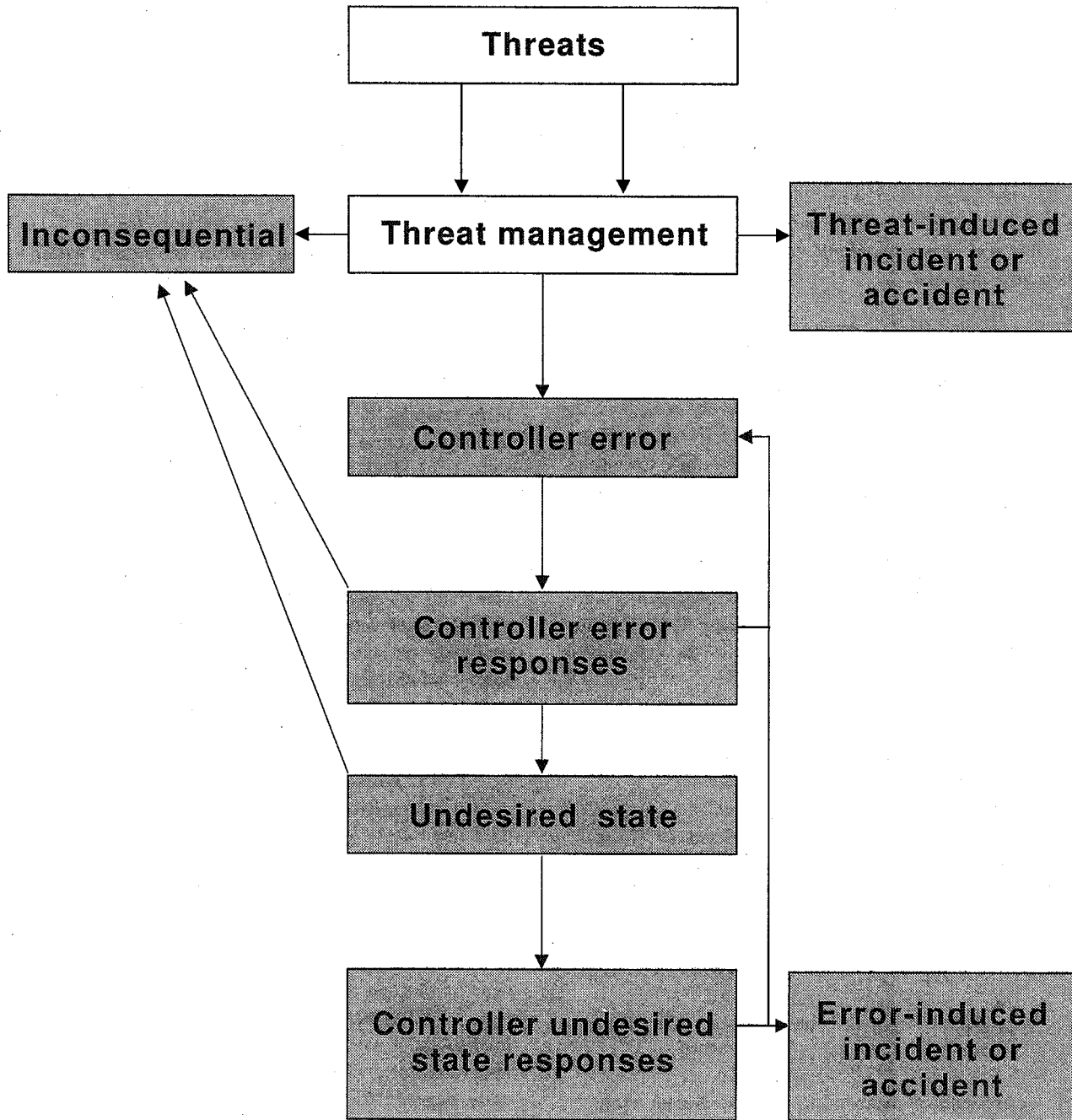
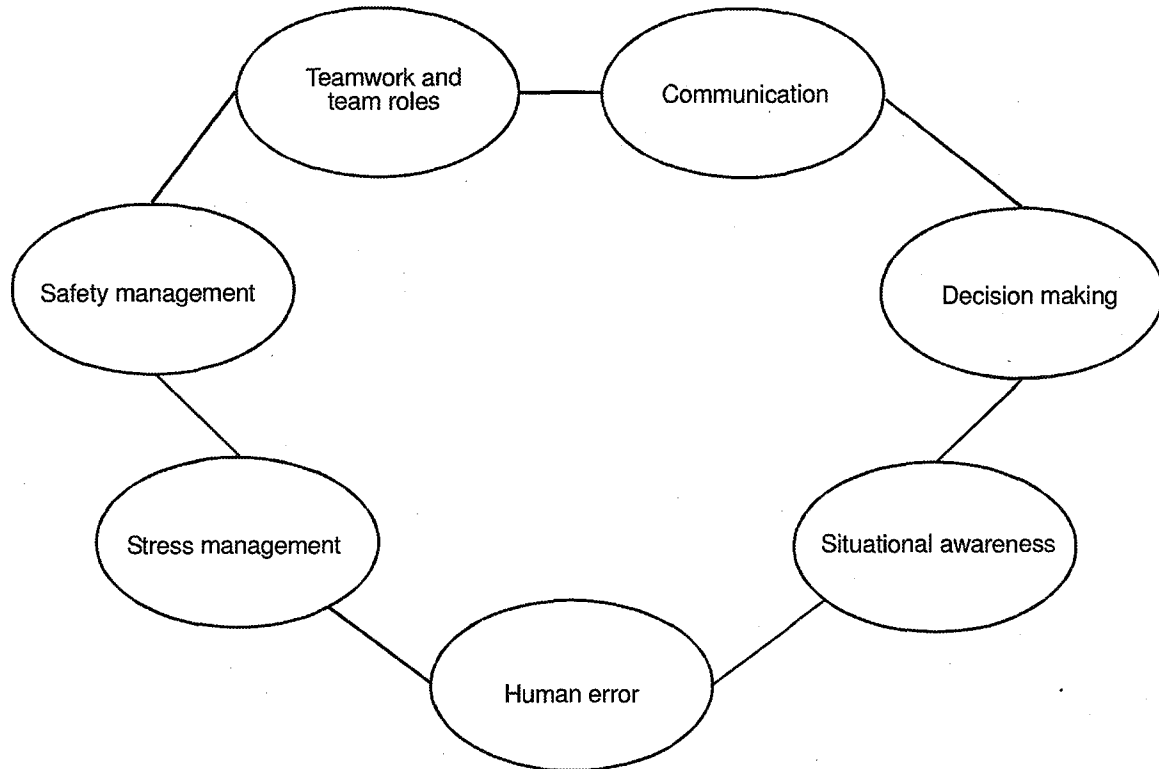

Figure 5-App-2. The threat and error management (TEM) model





**Figure 5-App-3. Elements of TRM training**

to explain to operational staff what TRM is, it is also important to make clear to them what it is not.

21. TRM is not a substitute for adequate training, nor is it intended to counteract poor procedures and documentation. It does not compensate for inefficient management structures or loosely and inadequately defined organizational roles. TRM is not intended as a replacement for technical training but should complement it. It is important that TRM be shown to be a means of increasing skill and professionalism by enhanced Threat and Error Management capabilities. The increased awareness of doing a more efficient job, coupled with an enhanced sense of working as a part of a larger and efficient team, will also lead to improved job satisfaction which in turn is likely to further

improve professionalism and efficiency. This is of benefit to the staff themselves and the organizations in which they work.

#### TRM Introduction Guideline 1

The practical benefits of enhanced team performance for both management and operational staff should be communicated as early as possible. This will increase the necessary commitment to develop and reinforce TRM as a tool for TEM throughout the organization.

**TRM objective**

22. In order to enhance Threat and Error Management (TEM) capabilities within ATS teams, a TRM course should be introduced to train operational staff in behavioural strategies. TRM training seeks to ensure the effective functioning of operational staff through the timely and proficient use of all available resources aimed at the safe and efficient flow of air traffic. Key objectives for TRM training are to develop the team members' attitudes and behaviour towards enhanced teamwork skills and performance in Air Traffic Services.

23. Operational staff are trained in technical and procedural skills, and their abilities to cope with the various requirements of the job are usually carefully tested by a specially designed selection procedure. Within this procedure, operational staff are assessed to ascertain whether they have the aptitudes and attitudes required for the job concerned. TRM will use these aptitudes and attitudes to help operational staff understand and be aware of the following:

- teamwork and how it affects team functioning
- how behaviour and attitudes can have an influence in accidents and incidents.

After operational staff have developed the required attitudes and behavioural skills they should then have the opportunity to practise them in a further training programme in an operational environment.

**TRM Introduction Guideline 2**

The main objective of TRM for operational staff should be the development of attitudes and behaviour that will contribute to enhanced teamwork skills and performance in order to reduce team work failures as a contributory factor in ATS-related incidents and accidents.

**Teamwork in ATS**

24. In ATS it is obvious that operational staff work in team structures, yet it is often difficult to define exactly how many people constitute a team or who is considered a member of a team, or what kind of cooperative and joint

work is regarded as teamwork. Figure 5-App-4 illustrates the possible teamwork relationships which a single operational controller might identify from his or her individual point of view.

25. Clockwise from the top, the picture shows the teamwork relationship between a controller and the pilots of the aircraft under his or her responsibility. The next team relationship is with the other controllers and/or flight data assistants on the same work floor. The controller also works closely with ATM support staff, the team leader and/or supervisor, and ATFM staff (that may be within the same unit or outside of it). Last but not least, there are teamwork relationships with other ATC units (TWR, APP and/or ACC) and other sectors, either within the same country or even in another country.

26. ATS teamwork obviously has to deal with cross-cultural aspects. This includes not only cultural aspects among ATS units of different countries and nationalities, but also among different units and teams within one nation. TRM is in this respect an aid to understanding and dealing with the cross-cultural aspects in an international ATS environment.

**TRM Introduction Guideline 3**

The initial phase of TRM should concentrate on teamwork between people in the same physical environment. At a later stage it may be considered to extend TRM to other teamwork relationships.

**Content of the TRM training programme**

27. The exact content of the TRM training programme may differ from one course to the next. It is dependent on the target population for the training and also on the specific needs and circumstances of the organization for which the training is developed. It is suggested, however, that as a minimum TRM training should address the aspects depicted in Figure 5-App-5.

28. The depth in which the various aspects should be addressed depends on the level of familiarity that the target population has with the subjects. The TRM development team should give careful consideration to what to include and to determining the appropriate depth of study for each of the subjects in the course.

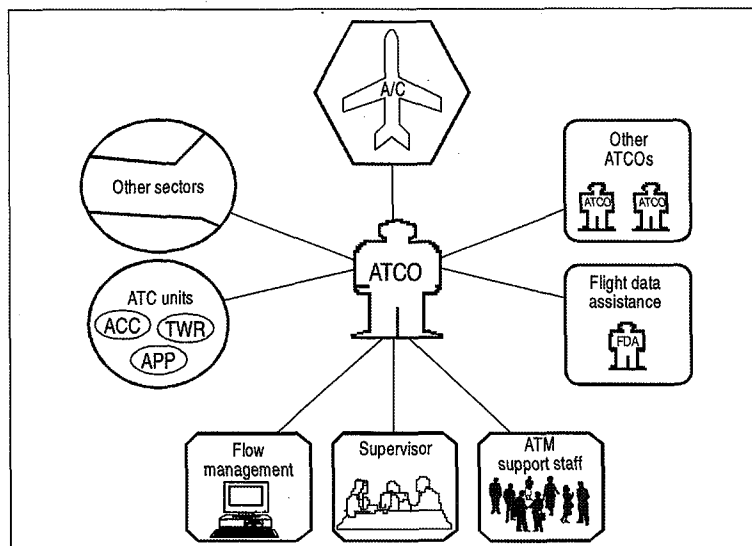

Figure 5-App-4. Teamwork relationships

**TRM Introduction Guideline 4**

A TRM training programme should address at least the following subjects: teamwork and team roles, communication, decision making, human error, situational awareness, stress management and safety management.

**Phases of the TRM training programme**

29. Just as in airline CRM training, there are three distinct phases in TRM training:

1. an introduction or awareness phase;
2. a practice session using practical exercises to highlight concepts taught in the awareness phase; and
3. a refresher training phase.

30. The introduction or awareness phase involves classroom type instruction and group exercises to explain the basic concepts of TRM. In general terms this instruction covers items including teamwork and team roles, communication, decision making, human error, situational awareness, stress management and safety management.

31. Ideally, one or more simulator training sessions follow on immediately from these theoretical aspects and may involve radar or other simulated operational environments. This training is similar to the Line Orientated Flight Training (LOFT) provided by airlines and involves specially designed exercises that highlight and demonstrate some of the theoretical aspects covered in the classroom sessions.

32. Finally, periodic refresher or reinforcement training should be provided during the operational career of participants. This should be at intervals of not more than five years and include briefings and/or exercises based on recent teamwork-related incidents and positive experiences.

**TRM Introduction Guideline 5**

TRM training should comprise three phases: an introductory/awareness phase, a practical phase and a refresher/reinforcement phase.

**Target population**

33. Besides controllers, operational staff from other disciplines within ATS also have the potential to impact in

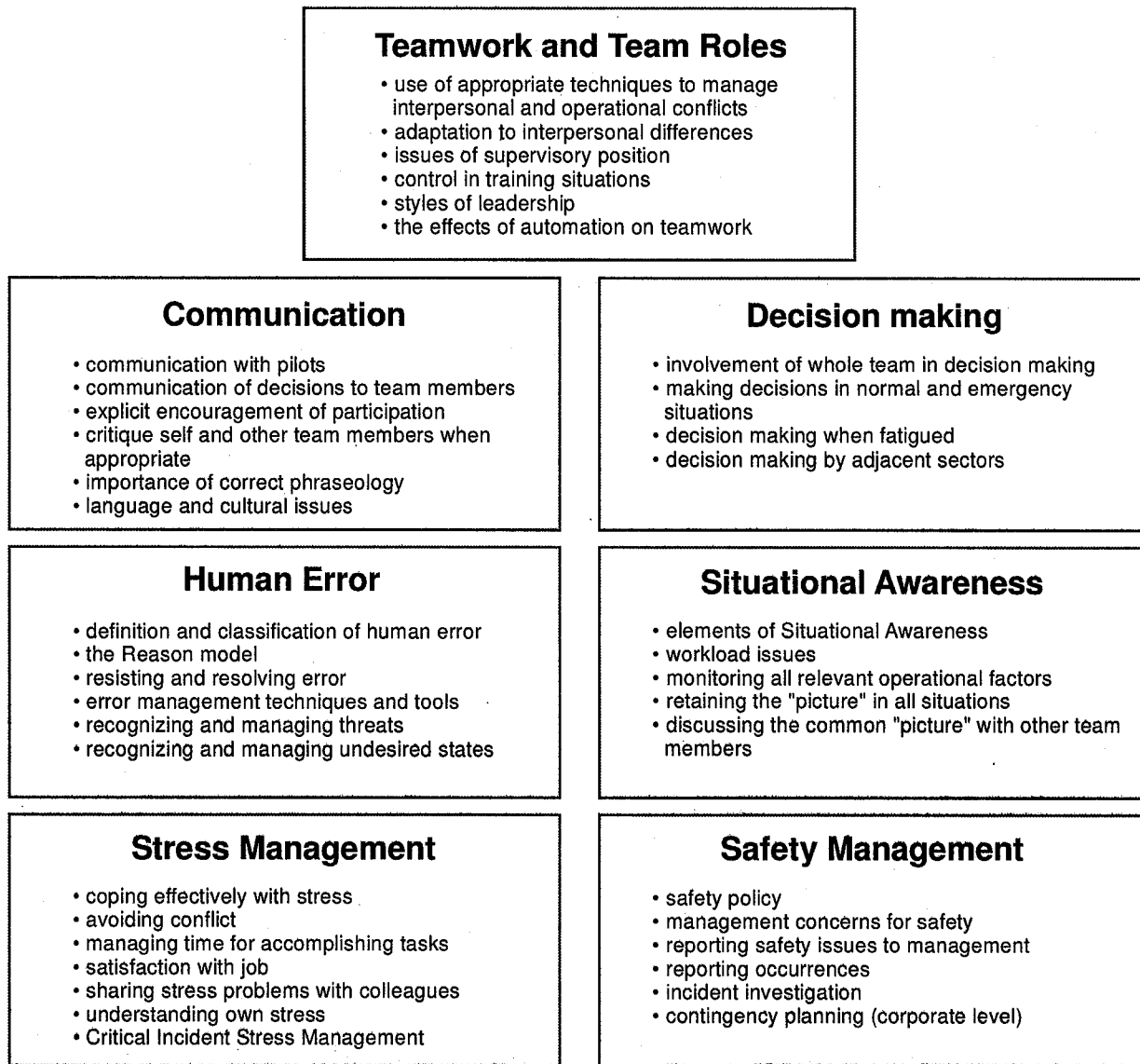

Figure 5-App-5. Aspects of TRM training

various ways on the safe and efficient operation of the system. While it is likely that these operational staff may all benefit from TRM, it must be recognized that the training should be given first to those who can have a major influence on the safety of the ATM system. This phased introduction will allow experience to be gained with TRM training within the organization.

#### TRM Introduction Guideline 6

TRM training should initially be provided to operational controllers, team leaders and/or supervisors and may later be extended to other operational staff in ATS.

#### Facilitators

34. A crucial factor in the acceptance of TRM as a concept is the selection of the right facilitators. Although human performance experts may be involved in the design of a specific course, experience has shown that there is a high acceptance level when the instruction given has operational relevance. It is therefore proposed that only ATS operational staff be involved in facilitating the training.

35. Furthermore it is important that facilitators be selected with care. A TRM facilitator should be someone with good presentation skills who is both persuasive and aware of the problems experienced in the operational environment. A facilitator should also be open to new concepts and be convinced of the importance and relevance of TRM training.

36. After selecting suitable facilitators it will be necessary to provide them with training in TRM concepts. This training, which should include input from human performance experts, will explain TRM concepts and methods in detail and demonstrate the importance of this type of training. It is recommended that a sufficient number of facilitators be trained.

#### TRM Introduction Guideline 7

TRM facilitators should be carefully selected and trained, and ideally should be current operational staff.

#### Practical relevance of TRM

37. If TRM is to be accepted by the target group it is essential that TRM principles be seen as relevant to the everyday working practices of that group. If participants in TRM courses cannot relate what is taught to their own experience, there is little possibility that their attitudes, and subsequently their behaviour, will change in the desired manner. There are a number of ways in which the content of TRM courses can be tailored to make what is taught more relevant and effective. These are discussed below.

38. The use of genuine examples, suitably de-identified, is considered a key enabler. The majority of units will have experienced ATS-related incidents, or at least have access to information about incidents which illustrate the importance of good teamwork. Ideally, a library of suitable incidents should be built up from which course designers can select appropriate examples that illustrate good and bad teamwork.

39. While it is important to use genuine scenarios to illustrate training points, it is also vital to keep courses updated with new examples. This is particularly true in the design and composition of refresher training courses which could lose a good deal of their impact if only familiar examples are included. One manner in which new material can be gathered is to encourage course participants to provide examples from their own experience. This presupposes that the course is run in an environment in which the participants feel sufficiently confident to reveal information on occurrences in which they themselves have been involved. Therefore, if the courses are conducted in an open, non-threatening atmosphere, it should be possible to generate this level of confidence.

40. The main aim of the course is to teach participants how to utilize good principles and practices in order to improve their own team functioning. When TRM principles are being taught it is important for the facilitator to recognize the less-than-ideal situations in which some operational staff may operate. Part of the process of rendering courses realistic and relevant will be by taking account of problems which arise in day-to-day work. Some course participants may work as part of a large team, others in small groups or as individuals. TRM training should therefore be designed with sufficient flexibility to be able to adapt to the different needs of course participants and to recognize and reflect the reality of the conditions under which they work.

41. Effective training requires good training materials but also depends on a suitable environment in which course participants can practise what they have learned. TRM

involves learning and using practical skills, and such skills are best learned and maintained through their use in a realistic setting. Training scenarios should ideally be set up in an ATC simulator to allow course participants to practise and develop TRM skills. These scenarios can comprise both normal operation and unusual or emergency situations where effective team functioning is vitally important.

#### TRM Introduction Guideline 8

Scenarios for training purposes should be realistic, relevant to course participants and regularly updated. The provision of a simulation environment should be considered such that participants can practise and reinforce TRM skills in both normal and emergency situations.

#### TRM training tools

42. At the beginning of a course it should be made clear to participants that TRM training is aimed at developing TEM skills. In addition, it is recommended that participation in certain exercises be on a voluntary basis.

43. An important benefit of TRM is that participants receive feedback on the way they cooperate when handling tasks and problems as a team. Feedback should therefore not only cover the results of teamwork but also the means of achieving it.

44. Best results can be expected in developing TRM skills by presenting video reconstructions or recordings of incidents/accidents and, in combination with simulator exercises, practising and learning new behavioural strategies. The use of role-playing is not advised, as its effectiveness in an environment with professionals has been found to be minimal.

#### TRM Introduction Guideline 9

TRM training tools and methods may comprise any combination of lectures, examples, discussions, videos, hand-outs, check-lists and simulator exercises. The use of role-plays is not recommended.

#### TRM extension

45. After starting with controllers, team leaders and supervisors, TRM training can be extended to other groups of ATS staff. Participant feedback will be used to improve the TRM concepts and training. Extending the target population to include information exchange between TRM-trained ATS staff and CRM-trained flight crews will further enhance the application of TEM.

#### TRM Introduction Guideline 10

As TRM training evolves, an extension of the target population and refinement of the TEM concept in the future ATM system should be considered.

#### Evaluating the results of TRM training

46. One of the more contentious developments of the introduction of CRM training for aircrews is the desire in companies to evaluate the effectiveness of the training programmes. A similar desire exists with TRM training for air traffic controllers. This desire partly stems from scientific needs, but there also is an economic component that seeks to justify the training expenses for the company or organization. The contention in many cases is based on the fact that the evaluation of the programmes consists of a subjective evaluation of the CRM/TRM skills of the participants.

47. However, it could be argued that evaluating the skills of the participants in a training environment provides little information on how valuable the training programme is in the everyday working environment. Also it might be better to look at the end-result of using a tool rather than looking at the skill with which the tool is applied. Therefore, since CRM and TRM are intended as tools for Threat and Error Management (TEM), the true value of the training can only be determined in the operational environment.

48. Together with the Human Factors Research Project of the University of Texas, airlines have developed a tool that provides reliable data on normal operations: the Line Operations Safety Audit (LOSA). LOSA enables operators to assess their level of resilience to systemic threats, operational risks and front-line personnel errors, thus providing a principled, data-driven approach to prioritize and implement actions to enhance safety.

*Note.— Information on LOSA is provided in the ICAO manual Line Operations Safety Audit (LOSA) (Doc 9803).*

49. It is important to realize that LOSA is a tool for airline use. LOSA cannot be applied in an ATC environment or in other operational aviation environments. Yet the concept of normal operations monitoring with the aim of obtaining data for safety improvements is considered valid and can be used in these other environments, provided the right tools to do so are developed.

50. In 2004 ICAO established a Study Group to develop a tool for use in the ATC environment with the name Normal Operations Safety Survey (NOSS).

## References

Guidelines for developing and implementing Team Resource Management. Eurocontrol (1996). HUM.ET1.ST10.1000-GUI-01. Brussels, Belgium. (Available on the Internet: [www.eurocontrol.int/eatmp](http://www.eurocontrol.int/eatmp).)

Team Resource Management test and evaluation. Eurocontrol (1999). HUM.ET1.ST10.2000-REP-01. Brussels, Belgium. (Available on the Internet: [www.eurocontrol.int/eatmp](http://www.eurocontrol.int/eatmp).)

# CHAPTER 6

## HUMAN FACTORS IN AIRCRAFT MAINTENANCE AND INSPECTION

### 6.1 INTRODUCTION

6.1.1 Aircraft maintenance is an essential component of the aviation system which supports the global aviation industry. As air traffic grows and the stringent requirements of commercial schedules impose increased demands upon aircraft utilization, the pressures on maintenance operations for on-time performance will also continue to escalate. This will open further windows of opportunity for human error and subsequent breakdowns in the system's safety net. There is no question that human error in aircraft maintenance has been a causal factor in several air carrier accidents. It is also beyond question that unless the aviation industry learns from these occurrences, maintenance-related safety breakdowns will continue to occur. From a Human Factors perspective, important issues have been uncovered during the investigation of these occurrences.

6.1.2 The objectives of this chapter are to provide practical Human Factors guidance — based on those issues — to those concerned with aircraft maintenance and inspection and to introduce the non-specialist to Human Factors issues in aircraft maintenance and inspection. It is intended to show how human capabilities and limitations can influence task performance and safety within the maintenance and inspection environments. This chapter also identifies sources of Human Factors knowledge and information.

6.1.3 Throughout the chapter, both the SHEL model and the Reason model are presented and repeatedly referred to in order to demonstrate the relevance of Human Factors to aviation safety and effectiveness. Information on aircraft accidents in which maintenance error has been identified is included to illustrate the issues discussed. The chapter advocates the importance of information exchange, the sharing of experience in maintenance operations among operators and the safety benefits to be gained therefrom. The need to adhere to established maintenance procedures by all concerned is emphasized and the negative aspects of non-adherence are explained using real-life

examples. New and improved training methods for aircraft maintenance personnel are briefly reviewed and possible advantages addressed.

6.1.4 This chapter also discusses the safety and efficiency gains from the provision of proper facilities and work environment. Job design, reward systems and selection and training of staff are also examined, emphasizing these gains. Obviously, a job design that works for one organization does not necessarily work for another. This chapter, therefore, stresses that each organization's culture must be considered separately if and when assigning work teams. It also introduces the reader to existing advanced job aids and to those expected to be available in the near future. The need to introduce new advanced technology vis-à-vis the gains to be had from their introduction — not only financially but, most importantly, in the enhancement of safety standards — is discussed. Although acknowledging advantages from advanced job aids, it nevertheless cautions that introduction of automation or new technology should take into consideration the capabilities and limitations of the operators who will use it. Automation should be designed to assist humans in performing their normal duties in a more efficient and *safe* manner.

6.1.5 This chapter:

- discusses Human Factors in aircraft maintenance and inspection;
- examines human error in aircraft maintenance and inspection;
- presents the issues affecting aircraft maintenance;
- considers teams and organizational issues in maintenance operations;
- deals with automation and advanced technology systems in aircraft maintenance;
- addresses the challenges for the future through error prevention considerations and strategies; and
- provides a list of references.



## 6.2 HUMAN FACTORS — AIRCRAFT MAINTENANCE AND INSPECTION

### Contemporary maintenance problems

6.2.1 There is no question that human error in aircraft maintenance and inspection has been a causal factor in several recent air carrier accidents. Whenever humans are involved in an activity, human error is a certain sequel. According to one source,<sup>1</sup> the number of *maintenance concern* accidents and incidents to public transport aircraft has increased significantly. This source defines *maintenance concern* as one which is not necessarily a maintenance error (it may be a design error) but one which is of concern to the maintenance personnel as frontline managers of technical problems in daily operations. The same source states that in the first half of the 1980s, there were 17 maintenance concern-related accidents and incidents, involving aircraft belonging only to Western operators and excluding all "routine" technical failures (engine, landing gear, systems, structure, component separations, ramp accidents, etc). All these accidents and incidents had serious consequences (fatal, serious damage, significant previous occurrences, significant airworthiness implications, etc). In the second half of the 1980s, the same source enumerates 28 accidents of maintenance concern, an increase of 65% over the first half of the decade. In the same period, traffic movements (flight departures, scheduled and non-scheduled) increased by 22%. In the first three years of the 1990s there were 25 accidents involving maintenance concerns. This compares with seven in the first three years of the 1980s.

6.2.2 Whether maintenance concern-related occurrences are a "new" phenomenon in aviation or whether they have always existed but have only recently been validated by statistics may be a matter of debate. Indeed, the awareness of the importance of maintenance to aviation safety may be the logical consequence of the gradual acceptance of broader, systemic approaches to aviation safety. Whatever the case may be, the increase in the rate of accidents and incidents involving maintenance concerns appears to be at least statistically significant. In the last ten years, the annual average has increased by more than 100% while the number of flights has increased by less than 55%.

6.2.3 Traditionally, Human Factors endeavours have been directed towards flight crew performance and, to a lesser extent, towards the performance of air traffic controllers. Until recently, available literature showed little consideration of the Human Factors issues which could

affect aircraft maintenance personnel who inspect and repair aircraft. This has been a serious oversight, since it is quite clear that human error in aircraft maintenance has indeed had as dramatic an effect upon the safety of flight operation as the errors of pilots and air traffic controllers.

6.2.4 Aircraft maintenance and inspection duty can be very complex and varied in an environment where opportunities for error abound. Maintenance personnel — at least in the most developed aviation systems — frequently work under considerable time pressures. Personnel at the maintenance base and at the flight line stations realize the importance of meeting scheduled departure times. Operators have increased aircraft utilization in order to counteract the economic problems that plague the industry. Aircraft maintenance technicians also frequently maintain fleets that are increasing in age. It is not uncommon to find 20 to 25 year old aircraft in many airline fleets, including those of major operators. In addition, many operators intend to keep some of these aircraft in service in the foreseeable future. Engine hush kits will make some older narrow-body aircraft economically and environmentally viable. However, these aircraft are maintenance-intensive. The old airframes require careful inspection for signs of fatigue, corrosion and general deterioration. This places an increased burden on the maintenance workforce. It creates stressful work situations, particularly for those engaged in inspection tasks, because additional maintenance is required and because the consequences may be serious if the signs of aging, which are frequently subtle, remain undetected.

6.2.5 While maintenance of these aging aircraft is ongoing, new technology aircraft are entering the fleets of many of the world's airlines, thus increasing the demands on aircraft maintenance. These new aircraft embody advanced technology such as composite material structures, "glass cockpits", highly automated systems and built-in diagnostic and test equipment. The need to simultaneously maintain new and old fleets requires aircraft maintenance technicians to be more knowledgeable and adept in their work than they may have been previously. The task of simultaneously maintaining these diverse air carrier fleets will require a highly skilled workforce with proper educational background.

6.2.6 There is at present a growing awareness of the importance of Human Factors issues in aircraft maintenance and inspection. The safety and effectiveness of airline operations are also becoming more directly related to the performance of the people who inspect and service the aircraft fleets. One of the objectives of this chapter is to bring to light Human Factors issues which are of significant importance to aviation safety.

### Human error

6.2.7 Human error rather than technical failures has the greatest potential to adversely affect contemporary aviation safety. A major manufacturer recently analysed 220 documented accidents and found the top three causal factors to be:<sup>2</sup>

- Flight crews not adhering to procedures (70/220)
- Maintenance and inspection errors (34/220)
- Design defects (33/220)

The following quotation illustrates this point:

"Because civil aircraft are designed to fly safely for unlimited time provided defects are detected and repaired, safety becomes a matter of detection and repair rather than one of aircraft structure failure. In an ideal system, all defects which could affect flight safety will have been predicted in advance, located positively before they become dangerous, and eliminated by effective repair. In one sense, then, we have changed the safety system from one of physical defects in aircraft into one of errors in complex human-centred systems."<sup>3</sup>

6.2.8 The increasing significance of human error is not unique to aircraft engineering. Hollnagel<sup>4</sup> conducted a survey of the Human Factors literature to identify the extent of the human error problem. In the 1960s, when the problem first began to attract serious attention, the estimated contribution of human error to accidents was around 20%. In the 1990s, this figure has increased four-fold to 80%. There are many possible reasons for this dramatic increase, but there are three which relate to aircraft engineering.

- The reliability of mechanical and electronic components has increased markedly over the past thirty years. People have stayed the same.
- Aircraft have become more automated and more complex. The current generation of Boeing 747-400s and Airbus A340s has duplicated or triplicated flight management systems. This may have reduced the burden on the flight crew but it has placed a greater demand on aircraft maintenance technicians, many of whom acquired their basic training in mechanical rather than computerized control systems. This suggests a mismatch of the Liveware-Hardware (L-H) and Liveware-Software (L-S) components of the SHEL model.

- Increased aviation system complexity creates the potential for organizational accidents in which latent procedural and technical failures combine with operational personnel errors and violations to penetrate or circumvent defences as the Reason model suggests. In short, complexity acts to shift the errors to other people.

### 6.3 HUMAN ERROR IN AIRCRAFT MAINTENANCE AND INSPECTION: AN ORGANIZATIONAL PERSPECTIVE

6.3.1 Human error in maintenance usually manifests itself as an unintended aircraft discrepancy (physical degradation or failure) attributable to the actions or non-actions of the aircraft maintenance technician (AMT). The word "attributable" is used because human error in maintenance can take two basic forms. In the first case, the error results in a specific aircraft discrepancy that was not there before the maintenance task was initiated. Any maintenance task performed on an aircraft is an opportunity for human error which may result in an unwanted aircraft discrepancy. Examples include incorrect installation of line-replaceable units or failure to remove a protective cap from a hydraulic line before reassembly or damaging an air duct used as a foothold while gaining access to perform a task (*among other failures, these examples also illustrate mismatches in the L-H interface of the SHEL model*). The second type of error results in an unwanted or unsafe condition being undetected while performing a scheduled or unscheduled maintenance task designed to detect aircraft degradation. Examples include a structural crack unnoticed during a visual inspection task or a faulty avionics box that remains on the aircraft because incorrect diagnosis of the problem led to removal of the wrong box.<sup>5</sup> These errors may have been caused by latent failures, such as deficient training, poor allocation of resources and maintenance tools, time-pressures, etc. They may also have been caused by poor ergonomic design of tools (*L-H flawed interface*), incomplete documentation or manuals (*L-S interface flaw*), etc.

6.3.2 Several widely publicized accidents have had human errors in maintenance as a contributing factor. The American Airlines DC-10 accident in Chicago in 1979<sup>6</sup> resulted from an engine change procedure where the pylon and engine were removed and installed as a unit rather than separately. This unapproved procedure (*a latent failure, probably with L-H and L-S mismatch involved*) resulted in failure of the pylon structure which became evident when one of the wing-mounted engines and its pylon separated from the aircraft at take-off. The resulting damage to hydraulic systems caused the retraction of the

left wing outboard leading edge slats and subsequent loss of control. In 1985, a Japan Airlines Boeing 747<sup>7</sup> suffered a rapid decompression in flight when an improperly repaired rear pressure bulkhead failed (*a latent failure, probably with L-H and L-S mismatch involved*). The subsequent overpressurization of the empennage and expansion of shockwave due to the explosive breakage of the spherical pressure bulkhead caused control system failure and the destruction of the aircraft with great loss of life. In April 1988, an Aloha Airlines Boeing 737<sup>8</sup> suffered a structural failure of the upper fuselage. Eventually the aircraft was landed with the loss of only one life. This accident was attributed to improper maintenance practices (*latent failures*) that allowed structural deterioration to go undetected.

6.3.3 In a detailed analysis of 93 major world-wide accidents which occurred between 1959 and 1983, it was revealed that maintenance and inspection were factors in 12% of the accidents.<sup>9</sup> The analysis proposes the following significant causes of accidents and their presence in percentages:

<i>Cause of accident</i>	<i>Presence (%)</i>
pilot deviation from standard procedures	33
inadequate cross-check by second pilot	26
design faults	13
<b>maintenance and inspection</b>	
<b>deficiencies</b>	12
absence of approach guidance	10
captain ignored crew inputs	10
air traffic control error/failure	09
improper crew response during abnormal conditions	09
insufficient or incorrect weather information	08
runway hazards	07
improper decision to land	06
air traffic control/flight crew communication deficiencies	06

6.3.4 In some accidents, where the error was attributed to maintenance and inspection, the error itself was a primary causal factor of the accident whereas, in other cases, the maintenance discrepancy was just one link in a chain of events that led to the accident.

6.3.5 The United Kingdom Civil Aviation Authority (UK CAA)<sup>10</sup> has published a listing of frequently recurring maintenance discrepancies. According to this listing, the leading maintenance problems in order of occurrence are:

- incorrect installation of components
- fitting of wrong parts

- electrical wiring discrepancies (including cross-connections)
- loose objects (tools, etc.) left in aircraft
- inadequate lubrication
- cowlings, access panels and fairings not secured
- landing gear ground lock pins not removed before departure.

6.3.6 An analysis of 122 documented occurrences involving Human Factors errors with likely engineering relevance, occurring in the 1989-1991 time period in one airline, revealed that the main categories of maintenance error were:<sup>11</sup>

<i>Maintenance error categories</i>	<i>Percentage</i>
omissions	56
incorrect installations	30
wrong parts	08
other	06

6.3.7 The majority of items often omitted are fastenings left undone or incomplete. The following example illustrates this point:

An aircraft experienced vibration problems with the right engine for two weeks. The engineers had looked at the problem and, believing that it was the pneumatics, had swapped the pressure-regulating valves. However, just to be on the safe side, they sent an aircraft maintenance technician along to monitor the engine readings on a flight from Amsterdam to Kos carrying a full load of tourists. Departure was uneventful except for a brief rise on the vibration indicator of the right engine at about 130 knots. On cruise, the vibration indicator was bouncing up and down between 1.2 and 1.3, still within the normal range. However, there was a feeling of unfamiliar and strange vibrations. Ninety minutes into the flight, the vibration indicator registered 1.5, just below the amber range. Fifteen minutes later, the indicator was bouncing up into the amber range. The crew reverted to manual throttle control and descended to FL 290, slowly closing the throttle. The right engine vibration indicator suddenly shot up to 5.2 and a dull tremor shook the aircraft. Then the readings returned to the normal range and the vibration disappeared. The Captain, however, decided to declare an emergency and land in Athens where he felt he could get technical support that would not be available at Kos. With the engine now at idle thrust, the engine readings

went back to the normal range and, as a result, the Captain decided to leave it well alone and not shut it down. On landing, the crew noticed some metal particles around the engine and discolouration on the blades that looked like oil.

When the report concerning the engine came out a few days later, it read:

“... that the cause of the loose disc was the nuts being fitted only 'finger tight' to the LP1 (low pressure) and LP2 disc bolts and not being torqued up allowing axial movement in and out of the curvature, causing heavy rubs and out of balance. The nuts became successively loose allowing the bolts to come free until only the residual four remained.”

6.3.8 The engine had been in for overhaul before the operator took delivery of the aircraft. There are 36 nuts and bolts that hold the LP1 and LP2 discs together. Apparently the technician working on them had finger tightened them and then decided to go to lunch. On his return he forgot to torque them as he had intended to do before he left for lunch. All but four of the bolts had fallen out and the remaining bolts only had 1/4 of an inch of thread left. Only the residual thrust held the engine together. Had the crew elected to shut the engine down, the consequences would probably have been catastrophic.<sup>12</sup>

6.3.9 Incorrect installation of components and lack of proper inspection and quality control represent the most frequently recurring maintenance errors. Examples abound. Consider the following occurrences:

- On 5 May 1983, Eastern Airlines Flight 855, a Lockheed L-1011 aircraft, departed Miami International Airport en route to Nassau, the Bahamas. A short time after take-off, the low oil pressure light for No. 2 engine illuminated. The crew shut down the engine as a precautionary measure and the pilot decided to return to Miami. Shortly thereafter the remaining two engines failed following a zero oil pressure indication on both engines. Attempts were made to restart all three engines. Twenty-two miles from Miami, descending through 4 000 ft, the crew was able to restart the No. 2 engine and made a one-engine landing with the No. 2 engine producing considerable smoke. It was found that all three master chip detector assemblies had been installed without O-ring seals.<sup>13</sup>
- On 10 June 1990, a BAC 1-11 aircraft (British Airways Flight 5390) departed Birmingham

International Airport for Malaga, Spain, with 81 passengers, four cabin and two flight crew. The co-pilot was the pilot flying during the take-off and, once established in the climb, the pilot-in-command handled the aircraft in accordance with the operator's normal operating procedures. At this stage both pilots released their shoulder harnesses and the pilot-in-command loosened his lap-strap. As the aircraft was climbing through 17 300 feet pressure altitude, there was a loud bang and the fuselage filled with condensation mist indicating that a rapid decompression had occurred. A cockpit windscreen had blown out and the pilot-in-command was partially sucked out of his windscreen aperture. The flight deck door blew onto the flight deck where it lay across the radio and navigation console. The co-pilot immediately regained control of the aircraft and initiated a rapid descent to FL 110. The cabin crew tried to pull the pilot-in-command back into the aircraft but the effect of the slipstream prevented them from succeeding. They held him by the ankles until the aircraft landed. The investigation revealed that the accident occurred because a replacement windscreen had been fitted with the wrong bolts.<sup>14</sup>

- On 11 September 1991, Continental Express Flight 2574, an Embraer 120, departed Laredo International Airport, Texas, en route to Houston Intercontinental Airport. The aircraft experienced a sudden structural breakup in flight and crashed, killing all 13 persons on board. The investigation revealed that the accident occurred because the attaching screws on top of the left side leading edge of the horizontal stabilizer were removed and not reattached, leaving the leading edge/de-ice boot assembly secured to the horizontal stabilizer by only the bottom attachment screws.<sup>15</sup>

6.3.10 In following the organizational perspective, several questions, raised as a result of these occurrences, need to be diligently answered. To address problems exposed as a result of accident investigation findings, contributing Human Factors issues, individual as well as organizational, must be identified.

6.3.11 In the case of the Eastern Airlines L-1011 aircraft, the National Transportation Safety Board (NTSB) concluded:

“the master chip detectors were installed without O-ring seals because the mechanics failed to follow the required work card procedures, and because they failed to perform their duties with professional care expected of an A&P (airframe and powerplant) mechanic.”<sup>16</sup>

6.3.12 Notwithstanding the conclusions of the NTSB, the findings and conclusions seem to have been limited to the notion of cause-effect relationships. Emphasis on factors such as multiple causation, mutual dependency and interaction of systems which are relevant to high-technology systems' safety was not as strong as it ought to have been to address both latent and active failures at their roots. It is the interaction of multiple failures, which are not expected to occur at the same time, rather than isolated individual actions, that explain why a particular accident or incident has occurred.

6.3.13 Chip detector installation was not a new task for the aircraft maintenance technicians at Eastern Airlines. The airline estimated that each technician involved had successfully performed over 100 chip detector changes. They were also in possession of a work card that specifically required the installation of the O-ring seals on the chip detector. They nevertheless failed to install the seals and thus the safety of the flight was seriously endangered. The investigation revealed that there were informal procedures not written on the work card but known to and adopted by most technicians in the maintenance and inspection departments. The records suggest that there were previous master chip detector installation problems and that the technicians were not routinely replacing O-ring seals on master chip detectors. This fact was known, at least, to one General Foreman who failed to take positive action to ensure compliance with the procedure as prescribed. One finding of the NTSB was that the aircraft maintenance technicians "had the responsibility to install O-ring seals"; however, a subsequent finding in the NTSB report states that "the mechanics had always received master chip detectors with 'installed' O-ring seals and had never actually performed that portion of the requirements of work-card 7204."<sup>17</sup> Latent organizational failure and L-S mismatches are obvious in this case.

6.3.14 Evidence available from organizational psychology confirms that organizations can prevent accidents as well as cause them. When viewed from an organizational perspective, the limitations of technology, training or regulations to counteract organizational deficiencies become obvious. Too often, safety promotion and accident prevention practices in the aviation industry have not taken into consideration the fact that human error takes place within the context of organizations that either foster or resist it.<sup>18</sup>

6.3.15 The immediate cause of the BAC 1-11 aircraft accident identified by the investigation was that the replacement windscreen had been fitted with the wrong bolts. Causal factors listed were:

- (i) A safety critical task, not identified as a "Vital Point" (*latent failure*), was undertaken by one individual who also carried total responsibility for the quality achieved, and the installation was not tested until the aircraft was airborne on a passenger-carrying flight (*latent failure*).
- (ii) The potential of the Shift Maintenance Manager (SMM) to achieve quality in the windscreen fitting process was eroded by his inadequate care, poor trade practices, failure to adhere to company standards and failure to use suitable equipment (*L-H mismatch*), which were judged symptomatic of a longer-term failure by him to observe the promulgated procedures.
- (iii) The British Airways local management, Product Samples and Quality Audits had not detected the existence of the inadequate standards used by the Shift Maintenance Manager because they did not directly monitor the working practices of Shift Maintenance Managers (*latent failure*).<sup>19</sup>

6.3.16 The windscreen change was carried out some 27 hours before the accident. Statistics maintained by the operator show that 12 No. 1 windscreens, left or right, had been changed on their BAC 1-11s over the last year, and a similar number the year before. The Shift Maintenance Manager, who was responsible for the windscreen replacement on the accident aircraft, had carried out about six windscreen changes on BAC 1-11s while employed by the operator.

6.3.17 Though the local management of the airline was cited for not detecting the existence of the inadequate standards used by the Shift Maintenance Manager, the findings and conclusions still followed the obvious notion of cause-effect relationships. In considering those accidents caused by human error, it is evident that we tend to think in individual, rather than in collective, terms. As a result, solutions are directed towards the individual, the front-end operator, thus shielding latent organizational errors, which are, for the most part, the root causes of such accidents. More often than not, latent failures are left untouched, intact, waiting to combine with an unsuspecting front-line operator's active failure or error — the last in a chain of errors — and cause an accident involving the loss of human life and the destruction of property. The fact that errors do not take place in a vacuum and that human error takes place within the context of organizations which either foster or resist it has long been put aside in order to identify an individual fully responsible for what has transpired. Therefore, it is imperative that systemic and/or organizational failures are scrutinized in order to uncover system-wide, error-inducing conditions.<sup>20</sup>

6.3.18 The investigation of the Continental Express Flight 2574 accident revealed that the attaching screws on the top of the left side leading edge of the horizontal stabilizer had been removed and had not been reattached, leaving the leading edge/de-ice boot assembly secured to the horizontal stabilizer by only the bottom attachment screws. The probable cause statement read:

"The National Transportation Safety Board determines that the probable cause of this accident was the failure of Continental Express maintenance and inspection personnel to adhere to proper maintenance and quality assurance procedures for the airplane's horizontal stabilizer deice boots that led to the sudden in-flight loss of the partially secured left horizontal stabilizer leading edge and the immediate severe nose-down pitch-over and breakup of the airplane. Contributing to the cause of the accident was the failure of the Continental Express management to ensure compliance with the approved maintenance procedures, and the failure of the FAA surveillance to detect and verify compliance with approved procedures."<sup>21</sup>

6.3.19 Although the report addresses latent failures as contributing factors to the occurrence, the emphasis in this statement is focused on the active failure of the maintenance personnel, making them the probable cause of the occurrence. In this and the previous cases, it is not difficult to see that "mechanic error" is replacing "pilot error" as the probable cause; this shifting of blame still brands a specific professional body as the sole entity responsible for the safety of the system and still fails to properly address systemic and/or organizational errors as the breeding grounds for human error in their real dimension. Over the last fifty years, ascribing "pilot error" as a probable cause of an occurrence failed to prevent accidents of similar causal factors. The reason is simple: *human error takes place within the context of organizations*. No accident, however obvious its causal factors seem to be, ever happens as a result of a single occurrence. A chain of latent failures is almost always present, depriving the last single error of the defence which could prevent it from becoming an accident. It is therefore imperative that causal factors in accidents are addressed in the organizational context in order to prevent them from occurring again and again. Aviation safety began to make optimal use of accident investigations lessons only after it had begun to address the organizational context of operations. These lessons are as applicable to errors committed in the maintenance base as they are to those committed in the cockpit or the ATC room. As is the case in the cockpit and ATC environment, accidents resulting from faulty maintenance or inspection reflect more on the organization than on the individual

who is at the end of the line (Reason's model simplifies this notion).

6.3.20 In keeping with this line of thinking, a dissenting statement in this particular report suggests that the probable cause cited should have read as follows:<sup>22</sup>

"The National Transportation Safety Board determines that the probable causes of this accident were (1) the failure of Continental Express management to establish a corporate culture which encouraged and enforced adherence to approved maintenance and quality assurance procedures, and (2) the consequent string of failures by Continental Express maintenance and inspection personnel to follow approved procedures for the replacement of the horizontal stabilizer deice boots. Contributing to the accident was the inadequate surveillance by the FAA of the Continental Express maintenance and quality assurance programmes."

6.3.21 The justification for this dissenting statement lies in the fact that the accident investigation report identified "substandard practices and procedures and oversights" by numerous individuals, each of whom could have prevented the accident. This includes aircraft maintenance technicians, quality assurance inspectors, and supervisors, all of whom demonstrated a "general lack of compliance" with the approved procedures. Departures from approved procedures included failures to solicit and give proper shift-change turnover reports, failures to use maintenance work cards as approved, failures to complete required maintenance/inspection shift turnover forms and a breach in the integrity of the quality control function by virtue of an inspector serving as a mechanic's assistant during the early stages of the repair work performed on the accident aircraft.

6.3.22 The investigation also discovered two previous maintenance actions on the accident aircraft, each of which departed from the approved procedures and involved employees different from those engaged in the de-icing boot replacement. The first event was the replacement of an elevator without the use of the required manufacturer-specified balancing tools. The second was the failure to follow specified procedures and logging requirements in response to an engine overtorque. Although these events were in no way related to the accident, the report indicates that they "suggest a lack of attention to established requirements for performing maintenance and quality control in accordance with the General Maintenance Manual (GMM)".

6.3.23 A detailed examination of the organizational aspects of the maintenance activities the night before the

accident reveals a mélange of crossed lines of supervision, communications and control. The multitude of lapses and failures committed by numerous airline employees, discovered during the investigation, is not consistent with the notion that the accident resulted from isolated, as opposed to systemic, factors. Based on the record, the series of failures which led directly to the accident cannot be considered the result of an aberration by individuals but rather reflects on the customary, accepted way of doing business prior to the accident. *Line management of an airline has the regulatory responsibility not only for providing an adequate maintenance plan (and we conclude that the GMM was, in most respects, an adequate plan) but for implementing the provisions of that plan as well. By permitting, whether implicitly or explicitly, such deviations to occur on a continuing basis, senior management created a work environment in which a string of failures, such as occurred the night before the accident, became probable.*<sup>23</sup>

#### Human error in the maintenance environment

6.3.24 There are unique characteristics which shape human error in the maintenance environment differently than in other operational environments, such as the flight deck or the ATC room. Push the wrong button or pull the wrong knob, issue a contradicting instruction, and the pilot or the controller will see the effects of the error before the aircraft completes its flight. If an accident or incident occurs, the pilot is always "on the scene" at the time of the accident or incident. If it is an air traffic controller who is involved, the ATC is nearly always on the scene or on real time. While this important characteristic may seem obvious for flight crew/ATC error, it does not always apply to aircraft maintenance error.

6.3.25 In contrast to the "real-time" nature of error in ATC and the flight deck, maintenance errors are often not identified at the time the error is made. In some cases the maintenance technician making the error may never know of the mistake because detection of the error could occur days, months or years after the error was made. In the case of the 1989 Sioux City DC-10 engine disk failure,<sup>24</sup> the suspected inspection failure occurred seventeen months before the aircraft accident.

6.3.26 When human error in maintenance is detected, usually through some system malfunction, we often know only the resulting aircraft discrepancy. What is rarely known is why the error occurred. In the realm of aircraft maintenance, there are no equivalents to the cockpit voice recorder, the flight data recorder or the ATC tapes to preserve the details of the maintenance job

performed. Additionally, maintenance self-report programmes have not progressed to the sophistication of those within the flight environment, such as the ASRS, CHIRP, etc. Thus, in most cases, the data to discuss maintenance error in terms of specific types of human error is simply not available. Errors are, therefore, discussed in terms of the aircraft discrepancy. Consider the following scenario: a New York-based line maintenance technician forgets to install an anti-vibration clamp on an engine-mounted hydraulic tube. Three months later, the tube suffers from fatigue in flight and causes the loss of a hydraulic system. Upon landing in London, aircraft maintenance technicians inspect the engine and find that the anti-vibration clamp was not installed. Do they know why? Most likely not since the error occurred three months ago in New York. Consequently a human error gets recorded as "clamp missing".

6.3.27 This unavailability of "scene-of-the-error" causal data represents a problem for an industry conditioned for decades to follow an approach to prevention and investigation strongly biased towards searching for some specific causal factor. Looking at the analysis of the causal factors of accidents and their percentage of presence discussed earlier, it can be seen that "pilot error" (the popular misnomer of human error committed by pilots) has been broken down into specific performance failures such as pilot deviation, improper crew response, improper decision, poor crew co-ordination, miscommunication with air traffic control, etc. In the same analysis, however, maintenance and inspection receives only one line: *maintenance and inspection deficiencies*. Notwithstanding all the other errors possible in the maintenance of a complex aircraft, every maintenance-related accident falls within that single line. Except for major accidents that are exhaustively re-created, identification of maintenance-related-error causal factors beyond this level is rarely seen.<sup>25</sup>

6.3.28 The maintenance- and inspection-error-related accidents of the BAC 1-11 and Embraer 120 aircraft are exceptions in that the accidents occurred soon after the active errors had been committed. This enabled the accident investigators to concentrate their efforts on site and to look closely into the activities of the individuals concerned as well as those of the organizations. The classic case of "displaced in time and space" was not a factor slowing, if not hindering, timely investigation of the occurrences. The opportunity to identify organizational errors, individual human error or error-inducing organizational practices was present, providing the chance to address accident-enabling practices at their source.

6.3.29 Statistics indicate that organizational or systemic errors within aircraft maintenance organizations

are not limited to one organization or one region. In the three accidents analysed here, the behaviour of the organizations and the individuals within the organizations before the occurrences was similar. For example:

- maintenance and inspection personnel failed to adhere to established methods and procedures (*active failure*);
- those responsible for ensuring adherence to established procedures and methods failed to supervise not in "one-offs" but in what were symptomatic of longer-term failures (*active and latent failures*);
- high-level maintenance management failed to take positive action to require compliance with procedures as prescribed by their respective organizations (*latent failures*);
- maintenance work was performed by personnel who were not assigned to do the job but who, with good intentions, started the work on their own initiative (*active failure fostered by the two previous latent failures*); and
- lack of proper and/or positive communication was evident, extending the chain of error which led to the accidents (*latent failure*).

6.3.30 One of the basic elements of the aviation system is the decision maker (high-level management, companies' corporate or regulatory bodies) who is responsible for setting goals and for managing available resources to achieve and balance aviation's two distinct goals: safety and on-time and cost-effective transportation of passengers and cargo. When viewed through both the Reason and the SHELL models, it is not difficult to see why and where errors were committed.

## 6.4 HUMAN FACTORS ISSUES AFFECTING AIRCRAFT MAINTENANCE

### Information exchange and communication

6.4.1 Communication is possibly the most important Human Factors issue in aircraft maintenance. Without communication among maintenance managers, manufacturers, dispatchers, pilots, the public, the government and others, safety standards would be difficult to maintain. In the maintenance realm there is an enormous volume of information that must be created, conveyed, assimilated, used and recorded in keeping the fleet airworthy. A

frequently quoted example is the paper stack, supposedly exceeding the height of Mt. Everest, that the Boeing Aircraft Company produces annually in order to support its aircraft operators. Airlines literally have warehouses full of paper that contain the historical records of maintenance of their aircraft.

6.4.2 It is most important that maintenance information be understandable to the target audience. The primary members of this audience are the inspectors and technicians who undertake scheduled aircraft maintenance and diagnose and repair aircraft malfunctions. New manuals, service bulletins, job cards and other information to be used by this audience should be tested before distribution to make sure that they will not be misunderstood or misinterpreted. Sometimes maintenance information is conveyed through a less-than-optimum selection of words. Anecdotal evidence suggests a case where a certain maintenance procedure was "*proscribed*" (i.e. prohibited) in a service bulletin. The technician reading this concluded that the procedure was "*prescribed*" (i.e. defined, laid down) and proceeded to perform the forbidden action. These types of problems are becoming more prevalent now that air carrier aircraft are being manufactured all over the world. Sometimes the technical language of the manufacturer does not translate easily into the technical language of the customer and the result can be maintenance documentation that is difficult to understand. Since so much maintenance information is written in English, there is a strong case to be made for use of "simplified" English. Words that mean one thing to a certain reader should mean the same thing to every other reader. For example, a "door" should always be a door. It should not be referred to as a "hatch" or a "panel".

6.4.3 Communication with the aircraft manufacturer, as well as between airlines, can be crucial. If an operator discovers a problem in maintaining its aircraft that could degrade safety, then that problem should be communicated to the manufacturer and to other operators of the same aircraft type. This is not always easy to do. Industry cost control measures and competitive pressures may not place a premium on communication among airlines. However, civil aviation authorities can play an important role by encouraging operators under their jurisdiction to interact frequently with one another and the manufacturer of the aircraft they operate. A maintenance-related incident in one airline, if made known to other operators, could easily prevent an accident from happening. The accident record has no shortage of accidents that could have been prevented if incident information from airlines had been made known to the industry. The investigation of the American Airline DC-10 accident at Chicago in 1979 revealed that another airline, using the same unapproved engine change procedures, had discovered that the



procedure caused cracks in the pylon attachment area and, as a consequence, had reverted to using the approved procedures. It is believed that if the airline had shared its experience with the other operators of similar aircraft, the accident at Chicago could have been prevented. However, for such co-operation to succeed and flourish, information disseminated under such co-operation must be strictly used for accident prevention purposes only. The use or misuse of such information to gain a marketing advantage over the reporting airline can only result in stifling all safety-related interactions among operators.

6.4.4 Lack of communication within an airline's maintenance organization can also have a very serious negative impact on the airline's operation. The accidents discussed in 6.2 illustrate this problem. In all of those occurrences, lack of proper communication of action taken or action which needed to be taken was rampant, adding to the series of errors and, thus, the accident occurrences. Each investigation has revealed that a number of latent failures were evident and that there was a serious flaw in the L-L and L-S interfaces.

6.4.5 In the EMB-120 accident, the second shift supervisor who was responsible for the aircraft failed to solicit an end-of-shift verbal report (shift turnover) from the two technicians he assigned to remove both horizontal stabilizer de-ice boots. Moreover, he failed to give a turnover to the oncoming third shift supervisor and to complete the maintenance/inspection shift turnover form. He also neglected to give the maintenance work cards to the technicians so that they could record the work that had been started, but not completed, by the end of their shift. It is probable that the accident could have been avoided if this supervisor had solicited a verbal shift turnover from the two technicians assigned to remove the de-ice boots, had passed that information to the third shift supervisor, had completed the maintenance shift turnover form and had ensured that the technicians who had worked on the de-ice boots had filled out the maintenance work cards so that the third shift supervisor could have reviewed them (*latent failure and L-L mismatch*).

6.4.6 The two technicians were assigned to the second shift supervisor by another supervisor, who was in charge of a C check on another aircraft. This supervisor was given a verbal shift turnover from one of the technicians after he had already given a verbal shift turnover to the oncoming third shift supervisor, informing him that no work had been done on the left stabilizer. He failed to fill out a maintenance shift turnover form and also failed to inform the oncoming third shift supervisor. He failed to instruct the technician to report to the supervisor who was actually responsible for the assigned task or to the oncoming third shift supervisor. Instead, he

instructed the technician to report to a third shift technician, indicating what work had been accomplished. If this supervisor had instructed the technician to give his verbal shift turnover information to the second shift supervisor (responsible for the aircraft) or to the oncoming third shift supervisor and had instructed the technician to complete the maintenance work cards, the accident would most likely not have occurred (*a series of latent failures and L-L flaw at all levels*).

6.4.7 A second shift Quality Control Inspector assisted the two technicians in removing the upper screws on both horizontal stabilizers, signed out on the inspector's turnover sheet and went home. An oncoming third shift Quality Control Inspector arrived at work early, reviewed the second shift Inspector's turnover sheet and recalled no entry. Unfortunately, the oncoming Inspector reviewed the shift turnover sheet before the second shift Inspector wrote on it "helped mechanic pull boots." In addition, the second shift Inspector failed to give a verbal shift turnover to the oncoming third shift Inspector. It is believed that if the second shift Quality Control Inspector had given a verbal shift turnover to the oncoming third shift Inspector and had reported any work initiated regarding removal of the upper leading edge screws on both stabilizers, the accident would most likely not have occurred. In addition, as an Inspector, he was a "second set of eyes" overseeing the work of the technicians. By helping remove the upper screws, he effectively removed himself from functioning as an inspector.

6.4.8 One of the technicians, who assumed responsibility for the work accomplished on the aircraft during the second shift, failed to give a verbal shift turnover, per the airline's maintenance manual, to the second shift supervisor (responsible for the aircraft), who had assigned him the task of removing the de-ice boots. In addition, he failed to solicit and fill out the maintenance work cards from the second shift supervisor before leaving at the end of his shift (*again a series of latent failures and L-L mismatch*). It is further believed that, if the technician had given a verbal shift turnover either to the second shift supervisor responsible for the aircraft or to the oncoming third shift supervisor, who was working the hangar directly, and if he had solicited the maintenance work cards from the second shift supervisor, the accident would most likely not have occurred.

6.4.9 The accident investigation<sup>26</sup> revealed that there was a serious organizational flaw within the maintenance system of the organization. The paragraphs above each emphasize a failure of an individual but not the same individual; it is a group of individuals, i.e. an organization. The investigation further revealed that the action of these

individuals or of a group of individuals was not a one-time slip. Two previous maintenance actions taken on the accident aircraft departed from approved procedure and involved employees different from those engaged in the de-icing boot replacement. Although the actions were in no way related to the accident, the investigation indicated that they "suggest a lack of attention to established requirements for performing maintenance and quality control in accordance with the General Maintenance Manual". The behaviour of the maintenance technicians, as revealed by the investigation, can only be explained as a manifestation of the existence of a corporate culture which condoned unapproved practices and which lacked norms that condemned such behaviour within the organization.<sup>27</sup> An attitude of disregard of maintenance procedures, organizational policies or regulatory standards involves more than individual human performance issues, since such behaviour does not develop overnight.

6.4.10 Communication was also an issue in the blown-out windscreen accident.<sup>28</sup> A Stores Supervisor, who had been on the job for about 16 years, informed the shift maintenance manager of the correct specification of the bolts used to fit that windscreen but *failed to press the point (L-L mismatch)*. Communication which is weakly or unconvincingly conveyed is as good as no communication at all. This accident also illustrates a problem faced regularly by maintenance technicians, i.e. the pressure to make a gate time. Due to the high costs of aircraft, operators cannot afford the luxury of having back-up aircraft when maintenance cannot be completed on time. Scheduling of aircraft for service reflects a delicate balance between obtaining the maximum number of revenue flight hours and performing needed maintenance. Significant maintenance tasks must be accomplished quickly so that the aircraft can make its scheduled gate time. Passengers do not like maintenance delays and if they happen too often on an airline, business may be lost to a competitor. Aircraft maintenance technicians are keenly aware of this pressure and strive to accomplish their work in a *timely* manner. Clearly this can sometimes lead to compromised maintenance especially when, as so often happens, things do not go according to plan. Management's role is to ensure that their maintenance organizations are provided with adequate personnel and resources to prevent the type of work that results in degraded airworthiness. This problem, while not — strictly speaking — a communication issue, highlights the importance of an open, two-way exchange within maintenance organizations. Airline management needs to develop procedures and ensure their application to prevent dispatch of non-airworthy aircraft. One of the best ways of facilitating this activity is to maintain an ongoing dialogue with maintenance staff, encouraging them to report hazardous situations or practices.

## Training

6.4.11 Training methods for aircraft maintenance technicians vary throughout the world. In many States a common procedure is for a would-be technician to enrol in a relatively short-term (two-year) course of training at an aircraft maintenance technician training centre. These centres provide training in the skills required to pass examinations given by the civil aviation authority (CAA) for the Airframe and Powerplant (A&P) technician's licence or certificate. In addition, it is possible in many States to obtain certification through an apprenticeship-type programme whereby, over a period of years, individuals learn their craft using on-the-job training (OJT) methods.

6.4.12 In practice and as a general industry-wide trend, most graduates of A&P training institutes are not well prepared for the airline maintenance role. As students they spend a lot of their training time learning such skills as wood/dope/fabric repair and piston engine repair. These skills, while useful in maintaining the general aviation aircraft which abound, are not often needed in maintaining the fleet of complex, turbine-powered air carrier aircraft. Consequently, the airlines must provide a good deal of training for their maintenance staff. In some States, maintenance technician candidates have no prior training in training centres. In these cases, the airlines are required to provide practically all of the training.

6.4.13 Airline training should be a mix of structured classroom training as well as OJT. The problem with OJT is that it is difficult to manage, hence, the training outcomes can be expected to vary considerably. Often with OJT a more experienced technician demonstrates a maintenance procedure to a junior or less experienced person. The trainee is expected to assimilate the training and demonstrate this newly acquired knowledge to the satisfaction of the trainer. If all goes well the trainee is expected to successfully perform the task, unsupervised, in the future. On the other hand, the senior technician/trainer may not be an effective teacher or the training environment (outdoors, night-time conditions) may not be conducive to training. The student may not know enough about the system which is being used for training to ask questions that might make the difference between successful or unsuccessful training. Other problems include training to perform certain tasks which may be difficult to learn in one session. Successful accomplishment of such tasks is heavily reliant on operator skill as there is as much "art" as there is "science" in these tasks.

6.4.14 OJT should be controlled and supervised. Trainers should be instructed in training procedures that will optimize student learning. On-the-job trainers should

be selected both for technical skills and for the motivation to train others. Maintenance shop managers should recognize that a good technician does not necessarily make a good instructor. Regardless of their personal capabilities to perform a given task, experienced technicians can be good or bad trainers and training outcomes can be expected to be similarly good or bad. The safety consequences are too obvious to require further elaboration. Trainees should be given graduated experiences so that, for example, they are trained in light scheduled maintenance work and move on to successively more difficult problems rather than start out immediately on heavy maintenance work. Records of OJT performance should be kept and remedial training provided as necessary. OJT should be scheduled as much as possible and should not be reliant on unpredictable aircraft malfunctions to provide training opportunities.

6.4.15 The growing complexity of modern air transport aircraft makes it necessary to provide more formal classroom-type training. With, for example, glass cockpits and sophisticated electronic systems, it is important to provide extensive classroom-based training on underlying system principles. This is difficult to do with OJT. Here, as well, it is very important that classroom instructors be extensively prepared for their task. It is not enough to simply dub a senior technician a teacher. In addition to being a subject matter expert, the instructor must also know how to teach, i.e. how to present information clearly, how to seek feedback from the students to ascertain that they are learning, how to determine problem areas and be able to provide remedial instruction. Most major airlines maintain training departments staffed with skilled instructors. However, this is not always the case with smaller carriers and in fact such departments are rarely seen in many commuter-type operations. In the meantime, commuter aircraft are also becoming as complex as aircraft operated by the major airlines. The challenge for these operators with limited resources is to develop methods to ensure that their maintenance technicians receive all the training required to maintain a fleet of modern aircraft. This may include taking maximal advantage of manufacturer-provided training and negotiating for follow-up training as part of an aircraft acquisition agreement.

6.4.16 Computer-based instruction (CBI) is found at some airlines depending on the size and sophistication of the training programme. However, most of the CBI currently in use would now be considered early or old technology. New training technologies are being developed which may complement or, in some cases, even replace OJT and classroom methods. Certainly these new training technologies would be expected to replace old-style CBI. Early CBI, which is still in use today, provides tutorial-

type instruction usually followed by screen-presented multiple choice questions on the tutorial material. An incorrect answer keyed in by a student is typically met with a buzzer sound and the words "wrong answer — try again". The student can keep guessing until the right answer is chosen, but usually little or no remedial instruction is given with these systems.

6.4.17 Today's students have greater expectations from interactive computer systems including training systems. In many States including a number of developing States, secondary or high school students have already had some exposure to personal computers and to computer games available for home televisions. These devices do provide considerable feedback and performance rating features found in new technology training systems. Similarly, newer CBI systems offer training that adapts to the students' knowledge and skill. However, advanced technology CBI must have a reasonable degree of intelligence comparable to that of a human instructor. More than the instructions and feedback on what needs to be done or on how one is performing, new technology should be able to provide systemic tutoring. Systems capable of such endeavours are now available in some high-technology training establishments. These new systems are called Intelligent Tutoring Systems (ITS). The features that set ITS apart from the less proficient CBI systems are software modules that emulate students, subject matter experts and instructors. This is done with an extensive set of rules related to the functions, operating procedures and component relationships of the system or device under study.

6.4.18 The primary components of an ITS are shown in Figure 6-1. At the centre of the figure is the instructional environment. For aviation maintenance training, this environment is usually a simulation. The expert model or module on the right of the figure must contain much of the same knowledge about a system or device that a human expert would possess. The student model at the bottom of the figure can be based on required student knowledge and on critical actions the student must take during interaction with the instructional environment. This model also contains a current file of students' actions as well as historical files describing students' preferred learning styles, previously mastered lessons and typical errors. The instructor or pedagogical model on the left provides the subject matter expert's knowledge in a way that optimizes student learning. This module sequences instruction based on student performance and provides appropriate feedback, remedial instruction and suggestions for further instruction outside of the ITS environment as needed.

6.4.19 ITS have been found to be very effective for training in the diagnosis and maintenance of complex high-technology equipment. They have a number of

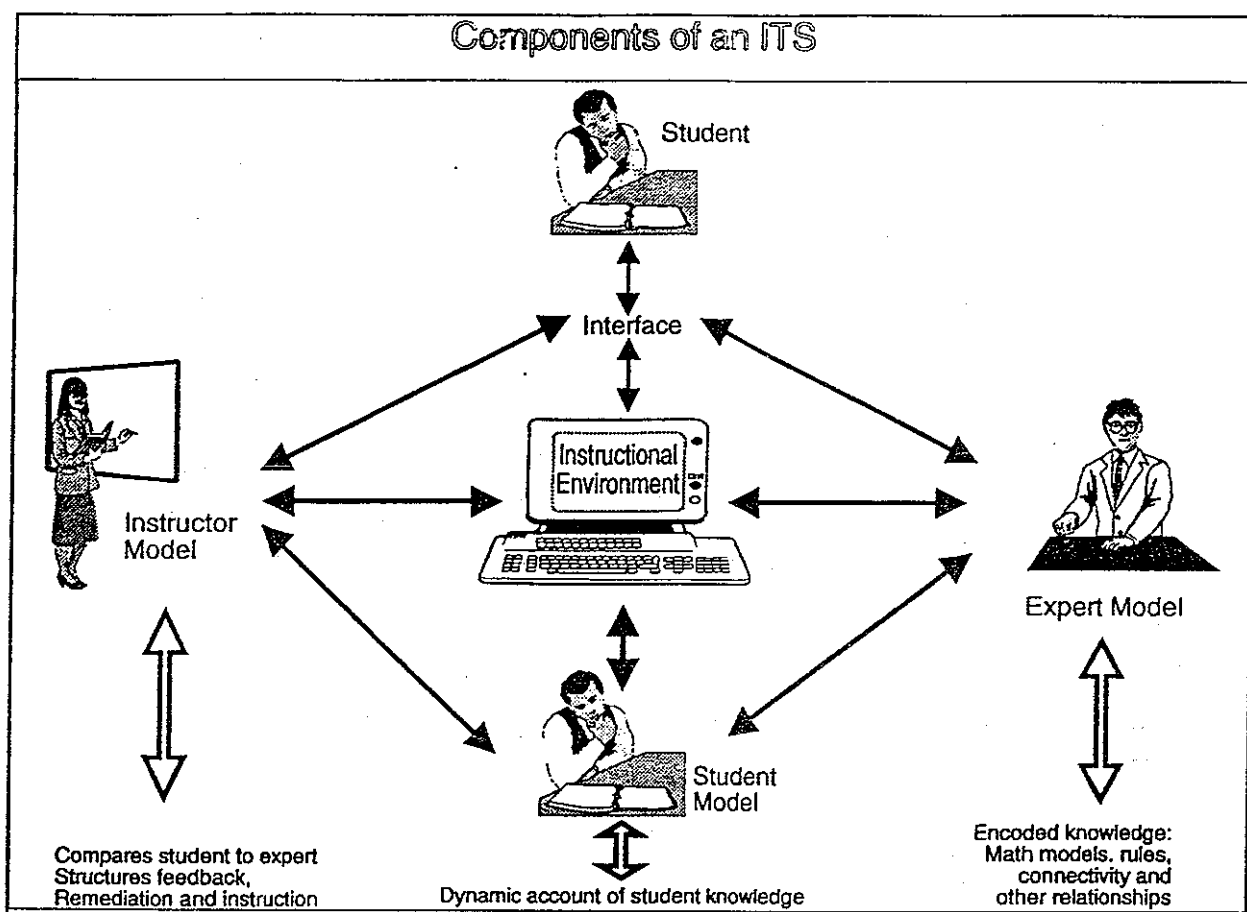

**Figure 6-1. The components of an intelligent Tutoring System**  
(Modified version from Polson & Richardson, Psootka et al., 1988)

advantages over traditional training methods including the capacity to provide “just-in-time” training or refresher training immediately before maintenance work is started. Also with ITS, training is under the students’ control and can be scheduled, paced or repeated at the students’ discretion. There is a feeling, in some circles, that these systems may prove to be too complex for widespread use. It is possible that these feelings spring from lack of experience with this technology rather than from an evaluation of technical and training staff capabilities. Operators and civil aviation authorities are urged to keep an open mind about the use of these new technologies lest they deprive their airlines of important capabilities which could have very significant safety implications.

#### The aircraft maintenance technician

6.4.20 Due to the increasing complexity of new aircraft, maintenance is becoming a more critical function. In the early days of aviation, aircraft maintenance was

considered a higher level of automotive maintenance not far removed from that of an automobile and similar skills could be successfully employed in either endeavour. Such consideration could not survive for long as aircraft technology quickly developed into a much more complex technology. Today aircraft maintenance technicians must know a good deal about system theory, be able to perform complex tests and interpret results, maintain structural elements that differ greatly from typical riveted aluminum structures and evaluate sensitive electronic and automated systems where a mistaken application of the simplest task can cause considerable loss in damage. Trends in aircraft and systems development clearly indicate that future aircraft technicians, in order to perform successfully, will need to be highly educated and trained to the level of a degree in engineering or its equivalent.

6.4.21 Even though many, if not all, airlines today are experiencing few problems recruiting qualified maintenance personnel, this may not be the case in the future. Competition from other industries — possibly with

better working conditions and more interesting work — and increasing demand for more people highly skilled in aircraft maintenance are a few of the reasons why airlines may find it more difficult to adequately staff their maintenance establishments in the future. For those facing this prospect, some thought should be given to possible actions to enhance future supplies of adequately trained maintenance personnel. Supporting quality secondary education in community schools and increasing awareness of the aircraft maintenance career among school-age groups are two relatively inexpensive means. Other methods include loan of equipment or instructors to A&P training schools, provision of training loans or grants to promising students in exchange for work agreements, development of more formal training or apprenticeship programmes and recruitment of maintenance talent from non-traditional groups such as women. Parenthetically, it is suggested that industry support and foster expanded computer education in secondary schools since, as the trend indicates, future maintenance activity may be heavily underpinned by computerized and automated systems even in those States that, at present, do not employ significant electronic support systems.

6.4.22 Aircraft maintenance is frequently performed at night. Physiologically and mentally we are most alert during daylight hours and prefer to rest or sleep at night. When job requirements disturb this pattern, work performance deficits can follow. This can certainly pose problems in aircraft maintenance where safety is vitally connected to error-free technician performance. In most maintenance-error accidents, like the ones discussed in this chapter, the faulty maintenance work which contributed to the accident was performed during night shift working hours (*inducing L-E interface flaw*). Operators should carefully examine work assignments for their effects on technicians and their work. Physically demanding tasks should not be followed by tedious work requiring intense concentration. Management should be aware of the hazards of such activities as repetitive inspection of identical items such as rivets or turbine blades. A long history of research shows that operator vigilance declines rapidly on these tasks and error can easily follow. Similarly, use of certain types of equipment is associated with work error. Old-style inspection devices rely heavily on technicians' skill in manipulating equipment and in detecting and interpreting subtle instrument indications. Couple these difficulties with a fatigued technician and the probability for error increases dramatically. Shift supervisors need to be especially observant of technician fatigue and to oversee and perform follow-up checks of tasks to discover any resulting errors. Inspection during daylight hours of maintenance work accomplished the previous night could also go a long way towards reducing the probability of an error such as happened on the accident aircraft.

6.4.23 Technician health and physical status can also influence work performance. Aircraft maintenance and inspection activity can sometimes be physically demanding. Climbing over wings and horizontal stabilizers and working in uncomfortable positions and in cramped or confined spaces are common. These can be demanding especially for the maintenance technician who is overweight, sick or poorly conditioned and could result in work being skipped, uncompleted or improperly performed. The need for good vision and sometimes for normal colour vision is important as well. Older people frequently need vision correction in the form of glasses or contact lenses. At present, there are no medical requirements for aircraft maintenance technicians. As is the case with many people, technicians may not attend to visual deficiencies on time, especially when we consider the fact that lacking periodic examinations, detection of gradual visual deficiency is difficult until vision has deteriorated significantly. Moreover, the technician may experience job insecurity and therefore avoid reporting failing eyesight.

6.4.24 Currently it is rare to find an operator or administration that requires regular medical screening of technicians to detect disorders that may impair their work performance. However, due to the increasing correlation between aviation safety and maintenance technician performance, it may be timely to consider implementing regular medical screening of aircraft maintenance technicians.

#### Facilities and work environment

6.4.25 To understand human error in maintenance, it is essential to understand the responsibilities and working environment of the aircraft maintenance technician. Work environment can have a strong effect on technician performance. While it is desirable to have ideal work conditions such as well lighted, comfortable hangars for aircraft maintenance work, such is not likely given the cost of building and operating these facilities at every airport served by airlines. Consequently, a lot of aircraft maintenance is performed under less-than-ideal-conditions including outdoor, night work in inclement weather.

6.4.26 One of the most important work parameters in aircraft maintenance is lighting. It is very difficult to provide adequate lighting for all aspects of maintenance work including inspection and repair. Poor ambient illumination of work areas was identified as a significant deficiency during the investigation of the accidents discussed in this chapter. In the BAC 1-11 aircraft accident, an adequately lighted working area may have made it possible for the shift maintenance manager to see

the excessive annulus of unfilled countersink which was easily discernible when viewed under good lighting conditions (*L-E mismatch*). In the EMB-120 accident, a third shift inspector had gained access to the top of the horizontal stabilizer to assist with the installation and inspection of the de-ice lines on the right side of the horizontal stabilizer. He later stated that he was not aware of the removal of the screws from the left leading edge assembly of the horizontal stabilizer and *in the dark outside the hangar*, he did not see that the screws were missing from the top of the left side leading edge assembly (*L-E mismatch*).

6.4.27 A great deal of lighting for specific tasks is provided by hand-held torches or flashlights. The advantages of these lights are that they are portable and require no set-up time. Disadvantages include lack of brightness and the fact that they usually encumber one hand, sometimes forcing maintenance work or inspection activity to be performed with the one remaining hand only. One frequently noted problem in several observed maintenance hangars is poor area lighting. Often hangar area lighting is provided by ceiling-mounted units. These hard-to-reach units are frequently dust- or paint-coated and burnt-out bulbs sometimes go unreplaced for long periods of time. In addition, the number and placement of these units are sometimes insufficient to provide good area lighting conditions. Area lighting in hangars should be at least in the order of 100 to 150 foot-candles to provide adequate lighting.

6.4.28 Maintenance and inspection tasks performed beneath aircraft structures and within confined spaces pose difficult lighting problems. The structure shades work points from area lighting and, similarly, cramped equipment compartments will not be illuminated by ambient hangar lighting. Special task lighting should be provided for these situations. Task lighting needs a range from 200 to 500 foot-candles, depending on the task. Affordable portable lighting units which can be positioned near work areas or attached to adjacent structures for the performance of specific tasks are available in various sizes and ranges. The use of such lighting systems could help alleviate some of the problems which may result from a liveware-environment mismatch.

6.4.29 Outdoor, night-time maintenance activity demands careful attention to lighting needs. A great deal of aircraft maintenance is performed under these conditions. There is an unfortunate tendency to rely on flashlights or ambient lighting from open hangar doors for this work because adequate portable lighting is either unavailable or time-consuming to obtain and set up. Management must be aware of the importance of providing and requiring the use of adequate area and task

lighting. It is not a trivial issue. Adverse occurrences, resulting, at least partly, from lack of adequate lighting, are often identified in many accident investigation reports.

6.4.30 Noise is another important work environment factor. Aircraft maintenance operations are usually intermittently noisy due to activities such as riveting, machinery operation inside hangars, or engine testing or run-up on ramps. Noise can cause speech interference and can also have health implications. Loud or intense noise tends to result in heightened response of the human autonomic nervous system. One of the results can be fatigue. Perhaps more important is the effect of noise on hearing. Regular exposure to loud noise can result in permanent hearing loss. Lower-intensity noise can cause temporary hearing loss which can have safety implications in the workplace. Missed or misunderstood communication resulting from noise interference or hearing loss can have serious consequences. Actions that can be taken by operators to deal with noise problems include controlling noise sources by enclosing or insulating machinery, isolating noisy activities so that fewer people are exposed, providing workers with hearing protection and requiring its use, reducing engine run-up or testing to the minimum acceptable and measuring noise levels in work areas. Noise monitoring can identify where problems exist, thereby enabling management to take corrective actions. The serious consequences of noise exposure should be stressed so that the workers see the need for hearing protection and for controlling noise wherever possible. Exposure to noise levels above 110 dB should not exceed twelve minutes in an eight-hour period and continuous exposure to 85 dB noise levels requires hearing protection. Both noise and light levels can be easily measured with relatively inexpensive hand-held meters. These are tasks that can be accomplished by the operator's health or safety departments or by supervisors who have been trained in the use of this equipment.

6.4.31 Toxic materials in aircraft maintenance have become more prevalent with the advent of more sophisticated aircraft that use composite materials in their structure or other hazardous substances such as tank sealants or structural bonding chemicals. Some non-destructive evaluation methods such as x-rays are also potentially hazardous. Employees should be informed of and trained on the hazards associated with handling toxic materials. They should be instructed in proper handling methods and provided with protective devices such as protective clothing, rubber gloves and goggles.

6.4.32 There are other hazards associated with aircraft maintenance. Chief among these is working on stands or other work platforms including movable buckets or "cherry-pickers" as they are sometimes called. As large

transport aircraft structures stand several tens of feet from the ground, a slip or fall from a work platform can cause very serious injury. Makeshift work stands and carelessly positioned ladders on slippery hangar floors should be avoided at all costs. Properly designed and used work support systems will, in the long run, be cost-effective because of reduced work error and fewer worker injuries.

6.4.33 The above information on noise, toxic materials, work stands and platforms is a good example of where and how a Liveware and Environment (L-E) interface flaw can occur in the maintenance shop. Although it addresses maintenance technicians' health and safety considerations, it has obvious implications for aviation safety. It is evident that technicians whose performance is impaired because of lack of health and personal safety provisions will be more likely to commit error affecting the over-all safety of aircraft operation. This is of great concern because, as a general rule, the effects of human error in maintenance are manifested far displaced in time and location.

## 6.5 TEAMS AND ORGANIZATIONAL ISSUES IN AIRCRAFT MAINTENANCE

### Team work

6.5.1 The importance of team work in aircraft maintenance cannot be overstressed. As aircraft and their systems become more complex, a greater emphasis on technical specialties (e.g. sheet metal/structures, electrical/electronics, hydraulics) is emerging. An unfortunate parallel trend is to organize the technical specialists into distinct departments or "functional silos", which tends to inhibit team work and communication.

6.5.2 A great deal of effort has been expended in recent years on the study of cockpit teamwork. These studies have resulted in training programmes with the familiar name of Cockpit (or Crew) Resource Management (CRM).<sup>29</sup> The results of this research support the conclusion that safety is enhanced when cockpit crews function as integrated, communicating teams rather than as a collection of individuals pursuing independent courses of action. The same conclusion might be assumed in the aircraft maintenance realm. Some airlines are either planning or are already providing CRM-type training in their maintenance organizations. This training, like its cockpit counterparts, emphasizes communication, leadership, assertiveness, decision making and stress management, skills that are important to *team* operations. At least one airline has shown an improvement in

important operating variables such as on time departures and job injuries after providing specially designed CRM training to its maintenance personnel.<sup>30</sup>

6.5.3 Another example of the benefits of a team approach to aircraft maintenance comes from the U.S. Air Force (former) Tactical Air Command. This organization originally employed a "dispatch" maintenance system where specialty technicians (e.g. hydraulic, electronics, etc.) could be dispatched to work on any of the aircraft stationed on a given base. A centralized organization called "Plans and Scheduling" directed all maintenance activity. All maintenance requests were passed to a sub-unit called "Job Control" which interpreted the requests, made decisions on who or what shop to dispatch and notified the appropriate organization to perform the work. Under this system the dispatched technician sometimes brought the wrong tools or parts or discovered on reaching the aircraft that he was the wrong technician for the job because Job Control was not tightly coupled with the system and frequently made wrong decisions. Technicians had no unit identity. They could be dispatched by Job Control to work on any of the aircraft assigned to a Wing. A team organization was not employed.

6.5.4 The results of this organizational scheme were apparent in a continuing decline in aircraft readiness. Units that had initially averaged 23 sorties a month per aircraft were averaging 11.5 sorties ten years later. Corrective action was clearly needed. As a first step, a team organizational structure was instituted. The 72 aircraft in a wing were assigned to three separate 24-aircraft squadrons. The maintenance technicians were divided into groups and assigned to one of the squadrons, and only those people assigned to a given squadron worked on their squadron's aircraft. A decentralized leadership structure was adopted with several levels of authority and responsibility. Goals and standards were established including a sortie requirement for each aircraft. The newly created maintenance teams were given the responsibility of ensuring aircraft readiness. Of course they were also provided with the required resources (parts, supplies etc.) to get their jobs done. Competition among the squadrons was fostered with sortie goals and squadron performance posted in prominent places. Technician status was boosted a number of ways. The technician was identified as a key player and not an anonymous cog in a wheel. Considerable effort was expended to establish a sense of unit identity and "ownership" in the structure of the organization.

6.5.5 The results were dramatic. Within a relatively short time, utilization rates improved by 43%, and aircraft readiness increased 59%. On-time departure rates increased from 75% to over 90%. These and other performance improvements show that organizational factors in the

workplace can have a strong influence on aircraft maintenance. The structure of an organization can impede or facilitate productivity. Teamwork, responsibility and especially leadership are key performance factors. Leadership at the working level seems to be encouraged by a decentralized structure. Competition and team identity are also important ingredients. Allowing the technicians to participate in decision processes will help to identify them as valuable contributors and foster interest in team results. By maintaining a distinct group of technicians who know each other and know one another's capabilities, team pride and performance are encouraged. The desired results, of course, are enhanced maintenance quality and a technician workforce that enjoys its work.

6.5.6 Observations made in a number of international air carrier maintenance facilities seem to indicate that an organizational concept similar to the "dispatch" system once used by the U.S. Air Force is prevalent. Distinct departments or shops with separate lines of accountability and limited goals are common. Individual rather than team performance is encouraged. Adaptability in response to unusual events is very important in aircraft maintenance, but can be disrupted by poor performance in one shop or department. Lack of team identity can lead to indifferent worker attitudes with predictable results. If individual technicians conclude that diligence will be for naught because of others' poor performance, then it is likely that diligence will become more and more rare over time.

6.5.7 Establishment of maintenance teams should be planned; it is not enough to simply separate people into groups and label them teams. Principles of job design should be employed when creating work teams. Space limitations prevent a detailed discussion on these principles; however, this chapter contains a list of recommended readings on this and other subjects. Well-designed teams can result in improvements in work performance and employee satisfaction, and poor team design can lead to effects in the opposite direction. Without proper management and regular evaluation of team performance, negative results are likely. For example, if work teams are given total autonomy on their productivity levels, then low productivity may result. Also, non-monitored groups can make poor decisions and sometimes inter- and intra-group conflicts can emerge. There may be a need to redefine goals and objectives as well as a need to exchange or replace team members for a variety of reasons as suggested above. This, of course, is a management function and well beyond the objectives of this chapter for detailed consideration.

6.5.8 Current thinking in job design focuses on what is called the motivational approach. The intention is to create jobs that are challenging, meaningful and

motivating. Employees should feel their work is important and productive. They should participate in decisions and have input into the methods used to accomplish their jobs. Research has shown that jobs requiring mental acuity are more motivating and satisfying. The work team concept seems to fit in especially well in this regard because there is a need for continuing interaction and communication among team members which stimulates thought and innovation. There is typically a certain amount of competition among team members for the leadership role which can be a positive force enhancing team performance.

6.5.9 Today, many industries, ranging from heavy manufacturing, like automobile assembly, to strictly service industries such as advertising firms, are implementing work teams. There is reason to believe that the team approach can be successfully and fruitfully employed in aircraft maintenance and the previously cited U.S. Air Force example supports this belief. However, careful planning and management are required to create and maintain effective work teams. The potential payoffs of well-functioning teams are improved productivity and safety as well as greater job satisfaction. Both of these are difficult to obtain simultaneously when dealing with individual jobs.

6.5.10 Some of the most important aspects to consider for work team design and management include job design, reward systems, selection and staffing, and training.<sup>31</sup>

### Job design

6.5.11 Proper job design can have an important effect on working productivity. While this fact has been recognized for some time, considerable research is still required to determine the optimum structure for jobs in particular occupational settings. As there are different approaches to job design, the optimum job design may require trade-offs among these approaches. Current attention is shifting from issues of the individual worker to issues focusing on work groups as a basic unit, especially in manufacturing and related industries.

6.5.12 One of the most important aspects of job design, based on a team concept, is to provide for self-management. To the extent possible, a team should have responsibility for its own activities, including such matters as making decisions about scheduling and employee assignments and participating in the selection of new team members. The principal responsibility of management is to provide resources so that the team operates smoothly. *Participation* by all team members is another aspect to be considered. There should be equal sharing of the burden



and jobs should be designed so that employee interaction is required. There should also be task *significance* — team members should feel that their contribution is important.

6.5.13 Moving to a team concept in aircraft maintenance is not easy. It may also not be suitable to all maintenance organizations. However, if implemented, team design must be carefully worked out and team performance regularly observed. What works in one airline may not work well in another. Each company's culture must be considered when designing work teams. The potential for worker satisfaction and for improved output appears to be sufficiently high with well-structured teams to be worth the effort to carefully examine this concept.

#### Reward systems

6.5.14 Team structure should provide for *interdependent feedback and rewards*. There should be a mechanism to identify individual performance as well as an individual's contribution to team performance. If the only output measure available is that of the total team, the contribution of specific individuals to team performance cannot be objectively defined. In that case, some employees may not do their share of the work. If everyone's performance is assessed and related to team productivity, all members of the team then feel that they have a common responsibility and will benefit accordingly.

#### Selection and staffing

6.5.15 Work teams should have membership skill diversity. For example, an aircraft maintenance team should not consist solely of powerplant or electronics specialists. The team should have a variety of the skills necessary to accomplish a number of tasks that comprise a work objective. Completion of landing gear maintenance, for example, may involve several specialties including hydraulic, electrical and rigging skills.

#### Training

6.5.16 Team members should be trained for their roles. This training is necessary especially for newly formed groups of people who were accustomed to working as individual technicians. The training should include methods of group decision making, development of interpersonal skills and working with other teams. Team members should also receive technical cross-training so that they can fill in for absent team members. In this way the team's productivity will not be overly impaired if a team member cannot perform.

6.5.17 Finally, work teams should consist of people who express a preference for team work. There are as many people who prefer to work alone as there are who like the team approach. This consideration is particularly important when and if one is attempting to establish self-managing teams. To succeed, such teams require members who are interested in the increased responsibilities accompanying team work.

## 6.6 AUTOMATION AND ADVANCED TECHNOLOGY SYSTEMS

### Automation and computerization

6.6.1 Technology in industry is increasing at a rapid pace and this is no less true in aircraft maintenance. Clearly, world-wide industry is entering an electronic era where more and more processes, operations and decisions are controlled by computers and advanced technology systems. In aircraft maintenance and inspection, a great deal of automation is currently in place but is usually somewhat removed from the technicians performing the actual work on aircraft. Generally speaking, information management is the area that has benefited most from applications of automation. All sorts of planning and reporting are now accomplished electronically. Other activities such as tool and inventory control, computer-aided design of tools and tracking of service bulletins and airworthiness directives are also done with computers, at least at the maintenance shops of the major air carriers.

6.6.2 Most aircraft manufacturers either have or are developing electronic versions of their maintenance manuals. In this case, rather than searching through paper pages in a manual, a technician can seek the information he needs with a tape or disc and a computer or video monitor. Some sort of artificial intelligence is incorporated in some of these systems so that by use of a few key words, the information system will automatically display the pertinent parts of the maintenance manual that may be needed by the technician for a particular maintenance assignment. More advanced versions of these systems allow the technician to use a "mouse" or a pointing device to point to desired information items on a screen-displayed menu and then, with a push of a button, gain access to the maintenance manual information.

### Advanced job aid tools

6.6.3 Other technologies providing automated information which may find their way into civil aircraft main-

tenance applications are under development. One noteworthy example is the Integrated Maintenance Information System or IMIS. This system embodies a great deal of computer-derived technology that helps technicians diagnose aircraft and system malfunctions and perform required maintenance. The system is highly portable and can be carried to the malfunctioning aircraft much like any other tool a technician might need. IMIS has a liquid crystal display (LCD) and can provide enlarged views, parts lists, technician specialties required to repair a system, sequenced test and maintenance procedures and a host of other information that, for the most part, resides in printed information such as maintenance manuals and parts catalogue. The system can even be plugged into a specialized maintenance bus on the aircraft and automatically receive information on the status of aircraft systems. This in turn can be used to provide the technician with system evaluations and required remedial actions. IMIS is a good example of a job aid that can provide strong support to maintenance technicians. One of its best features is its portability because it saves a great deal of time that would normally be spent travelling back and forth between the aircraft and information sources such as technical libraries. This time can instead be fruitfully applied to the task the technician is best equipped to perform: maintaining the aircraft.

6.6.4 New technology computers have become smaller and smaller and some incorporate features such as handwriting recognition. This latter capability could be particularly useful in filling out the numerous reports and forms that are required in aircraft maintenance. By some estimates, technicians spend 25% of their time on paperwork, time that could be better spent on aircraft maintenance. If such a system had been in place and available to the technicians working on the EMB-120 aircraft discussed earlier, the accident might possibly have been prevented because work performed and work yet to be accomplished would have been filed properly and on time, making it clear to the incoming shift what work still needed to be completed. By automating the filing process to the extent possible and further automating the information filing activity into larger computer storage facilities, recording errors can be avoided, and great savings in clerical manpower can be obtained. Funds that are currently spent on these ancillary maintenance tasks could be devoted to actions that would have more direct safety pay-offs such as providing further training. Furthermore, aircraft maintenance technicians would have more time to perform their tasks, leading to a less hurried, and hence less error-prone, work environment.

6.6.5 Recently developed "pen" computers seem to be ideally suited for these tasks. The "pen" is actually a stylus which can be used to write on the computer screen.

The stylus can also be used to select items from screen-displayed menus, thus permitting the technician to quickly zero in on stored information required for maintenance. The pen computer can be used in conjunction with storage media such as compact discs to store and provide access to an enormous volume of information. The entire maintenance manual for an aircraft and additional information such as airworthiness directives, service bulletins, job cards and specialized inspection procedures can be quickly made available to the aircraft maintenance technician next to the aircraft. When the technician has completed the maintenance job, he can call up the required forms to document his work, filling them out on the screen with the stylus or an integral keyboard on the computer, and can store this information or dump it directly onto a mainframe computer. The automation technology needed to perform these kinds of activities exists today and is currently being tested. There is little question that this type of job-aiding automation, which is neither overly complex or expensive, will find its way into the aircraft maintenance workplace in due course. The training, experience and technical talent needed at present to carry out the tasks of an aircraft maintenance technician are more than sufficient to successfully use these automated job aids. It is reasonable therefore to expect this type of automation in aircraft maintenance to be implemented globally.

6.6.6 Introducing further and advanced automation in aircraft maintenance, it should be noted that automation, unless designed with the capabilities and limitations of the human operators in mind, can be a source of a different set of problems hindering rather than assisting the aircraft maintenance technician. Inevitably, such automation cannot serve the interests of safety or efficiency in aircraft maintenance. For this reason, it is appropriate to recognize that automation devices designed and manufactured to assist a human operator must of necessity be designed in accordance with the *principles of human-centred automation*.<sup>32</sup> Such a consideration will help ensure that advanced automated aids will serve the purpose they are designed for, without creating an overwhelming set of new and additional problems for the maintenance organization.

6.6.7 Other automated job aids are found on new transport aircraft. These systems have the capability to assess the status of on-board equipment such as engines and electronic systems. When an in-flight equipment malfunction is encountered on these aircraft, the information (problem) is automatically stored and telemetered to the aircraft maintenance base without any input from the flight crew. On landing, aircraft maintenance technicians can be standing by with required spare parts to quickly remedy the problem and get the

aircraft back into service. Obviously, not every device or system on the aircraft can be evaluated this way, but a great deal of diagnostic or test time can be saved when major systems malfunction on aircraft which have such built-in test equipment (BITE). The major safety pay-off of such a system is that maintenance problems are identified and corrected early in their development stage, thus relegating the solving of maintenance problems through trial and error to the history books. One of the big advantages of BITE is that aircraft system malfunctions are identified at a very early stage before they become a threat to the safety of the aircraft and its occupants. Another advantage is that flight crew members may be advised of and consulted on a developing maintenance problem, thus enhancing their decision-making capabilities to ensure the continued safe operation of the aircraft based on actual and timely facts.

6.6.8 *The technician's task is complex and varied and is performed at several different physical locations. Actual maintenance activity involves frequent access to confined or difficult-to-reach spaces and a broad range of manipulation of tools, test equipment and other devices. Maintenance work differs from that of pilots or air traffic controllers who perform more predictable activities at a single workstation, either a cockpit or an ATC console. Because of these differences it would be very difficult, if not impossible, to automate much of the work of the aircraft maintenance technician. Rather, most automation related to maintenance tasks will likely consist of improvements in diagnostic support systems. Closely allied with these job-aiding systems are computer-based training systems which were discussed in 6.4.*

6.6.9 This section presented a summary on automation and advanced job aid tools currently or soon to be available to assist aircraft maintenance technicians in accomplishing their tasks. There are other concepts under development at this time such as automated devices that will traverse an aircraft's external structure and inspect it for cracks, corrosion, damaged rivets and other flaws, significantly assisting the work of an inspector. Other ideas under study involve automation of human expertise. A large percentage of the airline maintenance workforce in the United States is now or will soon be ready to retire. This group has a tremendous body of knowledge on aircraft maintenance and inspection methods that will be lost when these individuals retire from the active workforce. If this expertise can somehow be captured, properly arranged and provided to the junior, less experienced workforce, then aircraft safety, at least from the maintenance experience point of view, will be retained and enhanced and great savings in cost and time will be realized. Some airlines are already working on this concept.

## 6.7 ERROR PREVENTION CONSIDERATIONS AND STRATEGIES

6.7.1 *It has often been advanced that no accident, however obvious its causal factors seem to be, ever happens in isolation. Analysis emanating from broadened perspectives that focus on safety deficiencies in systems rather than on individuals has allowed the identification of deficiencies at several stages of the aviation system. The aircraft maintenance shop is such an organization where focusing on system deficiencies rather than on individual errors would, in time, significantly minimize occurrences resulting from human error in maintenance. Considering the potential for failures and other shortcomings, human error in aircraft maintenance has been remarkably managed. Lessons learned over the past ninety years of aviation have rapidly made their way into the methods of aircraft and maintenance systems design. However, from the occasional occurrences, there appears to be significant potential for improvement.*

6.7.2 The complexity of maintenance error can range from errors as simple as a single aircraft maintenance technician forgetting to torque a finger-tightened screw to errors that cause a system-wide failure as in the accident investigations discussed in 6.2. In the cases of a significant breakdown of the maintenance system, not only was the primary maintenance task misperformed but many levels of defence (such as those which are discussed in the Reason Model) had to be penetrated in order for the error-tolerant maintenance system to break down so significantly.

6.7.3 In between these two extremes are the systematic errors that can be more readily traced back to some deficiency in the design of the aircraft or the management of the maintenance process. The maintenance community has become adept at dealing with these errors through redesign and process change. For example, units such as gauges, communication and navigation units, etc., which do not require taking the aircraft to the maintenance hangar for replacement (line replaceable units), are currently being designed with different size or shape electrical and fluid connectors so that cross-connection errors upon reassembly are eliminated. On the operational side, several aircraft maintenance departments have established sophisticated systems to ensure that work started on one shift is properly turned over to the next shift.

6.7.4 Errors, such as nuts and bolts not torqued, lockwire not installed and access panel not secured, continue to frustrate designers and maintenance managers because they are associated with such simple pieces of

equipment that redesign of the equipment or maintenance system seems impractical, if not impossible. These errors may not *always* be life-threatening; however, their operational and economic impact continues to be very significant. An example of such an error is when a maintenance technician forgets to torque a screw or nut that he has installed finger-tight. What appropriate change can be introduced, in the way aircraft maintenance is performed to prevent such an error from occurring or to help reduce the error rate? Remove all nuts and screws from the aircraft? Require duplicate torquing for all nuts and screws on the aircraft? Regardless of the economic environment faced by manufacturers or commercial airlines, neither of these changes would have much chance of implementation. These errors are not so much the result of system deficiencies, but more a reflection of inherent limitations in the technology of both aircraft design and maintenance systems. Theoretically, to reduce removal and installation errors, aircraft would need to be designed with just a few components, rather than the three to four million parts currently found in large commercial jet transport. However, today's technology requires the use of nuts and lockwire on aircraft. As a result, sooner or later, due to improper execution of a maintenance task, each of these parts will inadvertently be left off a departing aircraft.<sup>33</sup>

6.7.5 Graeber and Marx suggest that, in order to take the next significant step in maintenance error reduction, three issues should be addressed:<sup>34</sup> maintenance data should be organized in a form that allows study of the human performance aspects of maintenance; the gap between the maintenance community and psychology as it applies to aviation should be narrowed; and methods and tools should be developed to help aircraft designers and maintenance managers address the issue of human error in a more analytical manner.

**1. Maintenance data should be organized in a form that allows study of the human performance aspects of maintenance:**

Much of the work in the theory of human error revolves around the classification of error. For the cognitive psychologist, there are many classification schemes from slip/lapse/mistake, to errors of commission and omission, to skill-based, rule-based and knowledge-based errors, to systematic and random errors. Each of these classification schemes is applicable to errors in any context, including aircraft maintenance. While these classifications impart order to what otherwise could appear as meaningless errors, they have, for the most part, not been used within the aircraft

maintenance community. The problem for those in the "real world" of maintenance is that establishing the type of error provides little practical help in determining the underlying cause.<sup>35</sup> Unless the relevance between theoretical error classifications and the real-world management of maintenance error is made obvious, the distinction between slips, lapses and mistakes is of little help to the maintenance community.

Another approach to error classification which has been embraced by the aviation industry is to focus on cause or contributing factors. This is how the industry arrived at the statistics showing the high percentage of accidents attributable to human error in the flight deck. While appropriate for equipment failure, this approach has significant limitations when applied to human error. In 1991, Boeing conducted a study of maintenance-related accidents occurring during the previous ten years. After reviewing available data, analysts assigned contributing factors to the accident under each of the seven broad categories of performance-shaping factors listed below:

- tasks and procedures;
- training and qualification;
- environment/workplace;
- communication;
- tools and test equipment;
- aircraft design; and
- organization and management.

In an attempt to guard against the temptation to place blame, the maintenance technician was deliberately excluded from these categories. The over-all result, however, was a subjective list of causes placed under one or more of the seven performance-shaping categories. Consequently, placing "blame" emerged as one of the undesirable, and unavoidable, aspects of each accident. Two significant issues emerged from this analysis:

- a) Can particular biases that analysts are likely to bring to an investigation due to experience, training or expertise be controlled? For example, would a maintenance instructor be more likely to identify training as a deficiency in a particular accident or incident?
- b) Would the maintenance community embrace a study that relies heavily on subjective assessment?

Both of these questions point to the need for improved human performance data collection and investigation

techniques that provide an observable framework, minimize the need for subjective assessments and are understood and endorsed by aircraft designers and maintenance managers.

6.7.6 The answer to the first question has been extensively discussed in Chapter 2 as well as in Part 2, Chapter 4. It often seems that investigations into human performance simply trace error back to the careless and unprofessional work habits of the individual involved. Traditionally during investigation of accidents, backtracking occurs until all conditions pertinent to the accident are explained by abnormal but familiar events or acts. If an aircraft component fails, a component fault will be accepted as the prime cause if the failure mechanism appears "as usual". Human error is familiar to the investigator: to err is human. Therefore, the investigation quite often stops once the person who erred is identified.

6.7.7 Part 2, Chapter 4 proposes an approach to improve our human performance investigations and to eliminate these premature judgements against the human operator. While not attempting to discount individual responsibility regarding mishaps, the approach advanced by this manual suggests that system safety is best served if attention is focused on those elements within the system that are manageable. What is going on inside the heads of the maintenance workforce — as well as other operational personnel — is often the hardest factor to manage. Thus, to conduct analyses that will help improve the system, attributes of maintenance error that do not simply point to the maintenance technician involved and do not require subjective assessments of deficiency must be investigated. Factual threads among accidents, incidents and events that will allow members of the maintenance community to work together must be researched to improve the over-all margin of safety standards of the whole system.

6.7.8 The UK CAA study discussed in 6.2, listing the top seven maintenance problems in order of occurrence, represents an approach that relates to the maintenance process or behavioral task rather than to the actual human error or causal factor. At the highest level of maintenance processes, for example, we may identify errors associated with:

- equipment removal;
- equipment installation;
- inspection;
- fault isolation/troubleshooting;
- repair; and
- servicing.

6.7.9 Classifications of maintenance error based upon the process or task involved can provide tangible

near-term benefits. For example, the Aloha Boeing 737 structural failure in 1987 led to heightened awareness of the Human Factors associated with visual structural inspection.<sup>36</sup> As a result, the United States Federal Aviation Administration has spent a significant portion of its maintenance Human Factors research funding on visual inspection issues.

6.7.10 A more in-depth analysis of this approach for analysing and classifying human error in aircraft engine troubleshooting has proved beneficial to the design of maintenance training systems.<sup>37</sup> In the case of the Aloha Boeing 737 accident, the errors were classified according to information-processing steps within a particular task of troubleshooting. The basic categories were observation of system state, choice of hypotheses, choice of procedures and execution of procedures.

6.7.11 This process of behaviourally oriented classification avoids the pitfalls associated with the cause or contributing factors approach discussed earlier. There is less "blame" placed within this classification scheme as compared to the previous approaches discussed. Rather than reacting defensively, most people will view this type of analysis as generating simple facts, pointing the way for improvements within the process.

6.7.12 In addition to error classification, *prevention strategies* can also be classified. Classification of error prevention strategies in maintenance is important because it helps to increase the visibility of tools that may be utilized by manufacturers and maintenance managers in the management of human error in maintenance. Three classes of strategies to manage human error in the maintenance of aircraft are proposed. Each of these classes is defined in terms of its method for controlling error:

- a) **Error reduction.** Error reduction strategies are intended to intervene directly at the source of the error itself. Examples of error reduction strategies include improving access to a part, improving the lighting in which a task is performed and providing better training to the maintenance technician. Most error management strategies used in aircraft maintenance fall into this category.
- b) **Error capturing.** Error capturing assumes the error is made. It attempts to "capture" the error before the aircraft departs. Examples of error-capturing strategies include post-task inspection, verification steps within a task and post-task functional and operational tests.
- c) **Error tolerance.** Error tolerance refers to the ability of a system to accept an error without

catastrophic (or even serious) consequences. In the case of aircraft maintenance, error tolerance can refer to both the design of the aircraft itself as well as the design of the maintenance system. Examples of error tolerance include the incorporation of multiple hydraulic or electrical systems on the aircraft (so that a single human error can only take out one system) and a structural inspection programme that allows for multiple opportunities to catch a fatigue crack before it reaches critical length.

6.7.13 Of the three classes of prevention strategies, only error reduction addresses the error directly. Error-capturing and error tolerance strategies are directly associated with system integrity. From a system safety perspective, human error in maintenance does not directly or immediately cause an aircraft to be unsafe. Until maintenance technicians are working on aircraft in-flight, this will always be the case. It is the aircraft being *dispatched* with a maintenance-induced problem that is cause for concern.

**2. The gap between the maintenance community and psychology as it applies to aviation should be narrowed:**

Over the past fifteen years, the pilot community and psychologists working in the industry have spoken an increasingly common language. Significant Human Factors work related to the flight deck has been accomplished through the interdisciplinary teaming of pilots, engineers and psychologists. Concepts such as mode error and Crew Resource Management have become common ground on which psychologists and the operational community can work together to improve system safety.

With few exceptions, however, aircraft designers, manufacturers, maintenance technicians and psychologists are still worlds apart. Looking at the L-1011 chip detector example, the question to be asked is whether psychologists would have been able to identify better intervention strategies than those undertaken by the operator. Chapter 2 points out that much of the Human Factors effort to date, especially in aviation, has been directed at improving the immediate human-system interface. Error reduction has been at the heart of Human Factors activities. The chip detector mishap, though, was just one of the everyday errors that involve relatively simple components of the aircraft that have little chance of being changed. Chapter 2

contends that the most productive strategy for dealing with active errors is to focus on controlling their consequences rather than striving for their elimination.

In pursuit of reducing maintenance-caused accidents, psychologists must move beyond the individual human-machine interface issues to a collective systems analysis approach. For example, there are two major steps within error analysis. The first step, "contributing factors analysis", is concerned with understanding why the error occurred. For example, identifying why the aircraft maintenance technician forgot to torque the bolt he finger-tightened can be studied from a conventional behavioural/cognitive psychology perspective. The second major step, "intervention strategies analysis", is concerned with identifying the aircraft or maintenance system changes that should occur to effectively address the maintenance error.

6.7.14 Developing the strategies to address future occurrences of maintenance error requires skills that often extend beyond the Human Factors engineer or psychologist. To develop specific intervention strategies requires an understanding of system constraints, criticality of the error and its resulting discrepancy, as well as error management practices unique to aircraft maintenance.

**3. Methods and tools should be developed to help aircraft designers and maintenance managers address the issue of human error in a more analytical manner:**

Since the beginning of aviation, the maintenance community has continuously contributed to the improvement of the safety and effectiveness of flight operations. This has largely been accomplished without assistance from "foreign" disciplines, such as psychology. The design of the human interface of a sophisticated on-board maintenance system is a task that requires greater analytical skills and knowledge about human cognitive performance than those acquired through years of experience as a maintenance engineer. However, as Human Factors practitioners increase their involvement in maintenance error analysis, the fact that the bulk of error analysis and management today, as it will be in the future, is performed by aircraft designers, manual designers, maintenance trainers and maintenance managers must not be lost. Thus, the maintenance community must look to sources of external, interdisciplinary support as a resource to help understand the inherent capabilities and limitations of the aircraft

maintenance technician. As a resource, external sources should focus on the development of sound methods and tools that can be transferred to the design and operational environments. Through better methods and tools, the goal of improved error management will be achieved in a more rapid and systematic manner.

6.7.15 The investigation of Human Factors in accidents has clearly shown that addressing systemic or organizational shortcomings (*latent failures*) rather than individual errors (*active failures*) will positively contribute to significantly minimizing human error occurrences. Appreciation of this finding has led many safety organizations to pay increasing attention to organizational and cultural factors, both as accident-causal and accident-preventive factors. Better understanding of these factors will lead to a better understanding of human error in the organizational context. Chapter 2 maintains that knowledge gained in the understanding of management and organizational factors, both as causal and preventive factors, can be successfully used to face the challenges of the future in minimizing human error in the air transport industry.

#### LIST OF REFERENCES

- Air Transport Association (1989). "ATA Specification 104 Guidelines for Aircraft Maintenance Training". Washington, D.C.: Air Transport Association.
- Aviation Industry Computer Based Training Committee (1989). AICC Matrix Committee. "CBT Courseware/Hardware Matrix" (Report AGR 001, 22 December 1989). Washington: GMA Research Corporation.
- Aviation Safety Research Act of 1988, PL 100-591, 102 Stat. 3011 (1988).
- Baker, B. and A. Schafer. "Industrial Hygiene in Air Carrier Operations". Proceedings of the Fifth Federal Aviation Administration Meeting on Human Factors Issues in Aircraft Maintenance and Inspection — The Work Environment in Aviation Maintenance. January 1992. Washington, D.C.
- Barnett, M.L. (1987). *Factors in the Investigation of Human Error in Accident Causation*. College of Maritime Studies. Warsash, Southampton, United Kingdom.
- Campbell, R.J. "Measurement of Workforce Productivity". Proceedings of the Fifth Federal Aviation Administration Meeting on Human Factors Issues in Aircraft Maintenance and Inspection — The Work Environment in Aviation Maintenance. January 1992. Washington, D.C.
- Campion, M.A. "Job Design and Productivity". Proceedings of the Fifth Federal Aviation Administration Meeting on Human Factors Issues in Aircraft Maintenance and Inspection — The Work Environment in Aviation Maintenance. January 1992. Washington, D.C.
- DeHart, R.L. "Physical Stressors in the Workplace". Proceedings of the Fifth Federal Aviation Administration Meeting on Human Factors Issues in Aircraft Maintenance and Inspection — The Work Environment in Aviation Maintenance. January 1992. Washington, D.C.
- Drury, C.G. (1991). "Errors in Aviation Maintenance: Taxonomy and Control". Proceedings of the Human Factors Society 35th Annual Meeting, San Francisco, California.
- Drury, C.G. "The Information Environment in Aircraft Inspection". Proceedings of the Second Federal Aviation Administration Meeting on Human Factors Issues in Aircraft Maintenance and Inspection — Information Exchange and Communication. May 1990. Washington, D.C.
- Drury, C.G. and A. Gramopadhye. "Training for Visual Inspection". Proceedings of the Third Federal Aviation Administration Meeting on Human Factors Issues in Aircraft Maintenance and Inspection — Training Issues. November 1990. Washington, D.C.
- Embrey, D. (1975). *Training the Inspectors' Sensitivity and Response Strategy*. In Drury, C.G. and J.G. Fox (Eds.), *Human Reliability in Quality Control*, pp. 123-132, London: Taylor & Francis.
- Federal Aviation Administration. "The National Plan for Aviation Human Factors". Washington, D.C.
- Gallwey, T.J. (1982). "Selection Tests for Visual Inspection on a Multiple Fault-Type Task". *Ergonomics*, 25.11, pp. 1077-1092.
- Glushko, R. "CD-ROM and Hypermedia for Maintenance Information". Proceedings of the Second Federal Aviation Administration Meeting on Human Factors Issues in Aircraft Maintenance and Inspection — Information Exchange and Communication. May 1990. Washington, D.C.
- Goldsby, R.P. "Effects of Automation in Maintenance". Proceedings of the Fifth Federal Aviation Administration Meeting on Human Factors Issues in Aircraft Maintenance and Inspection — The Work Environment in Aviation Maintenance. January 1992. Washington, D.C.
- Gregory, W. (1993). "Maintainability by Design". Proceedings of the Fifth Annual Society of Automotive Engineers Reliability, Maintainability, and Supportability Workshop. Dallas, Texas.
- Hackman, J.R. (1990). *Groups that Work*. San Francisco: Jossey-Bass.
- Harle, J. "Industry and School Cooperation for Maintenance Training". Proceedings of the Fourth Federal Aviation Administration Meeting on Human

- Factors Issues in Aircraft Maintenance and Inspection — The Aviation Maintenance Technician. June 1991. Washington, D.C.
- Hollnagel, E. *Human Reliability Analysis — Context and Control*. Academic Press. San Diego, California. 1993.
- IES (1987). *IES Lighting Handbook — Application Volume*. New York: Illuminating Engineering Society.
- IES (1984). *IES Lighting Handbook — Reference Volume*. New York: Illuminating Engineering Society.
- Inaba, K. "Converting Technical Publications into Maintenance Performance Aids". Proceedings of The Second Federal Aviation Administration Meeting on Human Factors Issues in Aircraft Maintenance and Inspection — Information Exchange and Communication. May 1990. Washington, D.C.
- Johnson, R. "An Integrated Maintenance Information System (IMIS): An Update". Proceedings of The Second Federal Aviation Administration Meeting on Human Factors Issues in Aircraft Maintenance and Inspection — Information Exchange and Communication. May 1990. Washington, D.C.
- Johnson, W.B. (1987). *Development and Evaluation of Simulation-Oriented Computer-Based Instruction for Diagnostic Training*. In W.B. Rouse (Ed.), *Advances in Man-Machine Systems Research*, Vol. 3 (pp. 99-127). Greenwich, Connecticut: JAI Press, Inc.
- Johnson, W.B. and J.E. Norton. (1992). *Modelling Student Performance in Diagnostic Tasks: a Decade of Evolution*.
- Johnson, W.B. and W.B. Rouse (1982). *Analysis and Classification of Human Errors in Troubleshooting Live Aircraft Power Plants*. IEEE. Transactions on Systems, Man and Cybernetics.
- Kizer, C. "Major Air Carrier Perspective". Proceedings of the Second Federal Aviation Administration Meeting on Human Factors Issues in Aircraft Maintenance and Inspection — Information Exchange and Communication. May 1990. Washington, D.C.
- Majoros, A. "Human Factors Issues in Manufacturers' Maintenance — Related Communication". Proceedings of the Second Federal Aviation Administration Meeting on Human Factors Issues in Aircraft Maintenance and Inspection. May 1990. Washington, D.C.
- Marx, D.A. (1992). "Looking towards 2000: The Evolution of Human Factors in Maintenance". Proceedings of the Sixth Federal Aviation Administration Meeting on Human Factors Issues in Aircraft Maintenance and Inspection. Alexandria, Virginia.
- Marx, D.A. and R.C. Graeber (1993). *Human Error in Aircraft Maintenance*. Boeing Commercial Airplane Group. Seattle, Washington.
- Mayr, J. "Composites in the Workplace — Some Lessons Learned". Proceedings of the Fifth Federal Aviation Administration Meeting on Human Factors Issues in Aircraft Maintenance and Inspection — The Work Environment in Aviation Maintenance. January 1992. Washington, D.C.
- Peters, R. "State and Aviation Industry Training Cooperation". Proceedings of the Fourth Federal Aviation Administration Meeting on Human Factors Issues in Aircraft Maintenance and Inspection — The Aviation Maintenance Technician. June 1991. Washington, D.C.
- Rasmussen, J. and K.J. Vicente. (1989). "Coping with Human Errors through System Design: Implications for Ecological Interface Design". *International Journal of Man Machine Studies*, 31, 517-534.
- Reason, J. (1990). *A Framework for Classifying Errors*. In J. Rasmussen, K. Duncan and J. Leplat (Eds.), *New Technology and Human Error*. London: John Wiley.
- Reason, J. (1990). *Human Error*. Cambridge University Press, United Kingdom.
- Rogers, A. (1991). "Organizational Factors in the Enhancement of Military Aviation Maintenance". Proceedings of the Fourth International Symposium on Aircraft Maintenance and Inspection (pp. 43-63). Washington, D.C. Federal Aviation Administration.
- Ruffner, J.W. (1990). "A Survey of Human Factors Methodologies and Models for Improving the Maintainability of Emerging Army Aviation Systems". US Army Research Institute for the Behavioural and Social Sciences. Alexandria, Virginia.
- Shepherd, W.T., W.B. Johnson, C.G. Drury and D. Berninger. "Human Factors in Aviation Maintenance Phase 1: Progress Report". FAA Office of Aviation Medicine Report AM-91/16, 1991. Washington, D.C.
- Shute, V. and W. Regian (Eds.). *Cognitive Approaches to Automated Instruction*. Hillsdale, New Jersey: Lawrence Erlbaum Associates, Inc., 195-216.
- Skinner, M. "Aviation Maintenance Practices at British Airways". Proceedings of the Fourth Federal Aviation Administration Meeting on Human Factors Issues in Aircraft Maintenance and Inspection — The Aviation Maintenance Technician. June 1991. Washington, D.C.
- Taggart, W. "Introducing CRM into Maintenance Training". Proceedings of the Third Federal Aviation Administration Meeting on Human Factors Issues in Aircraft Maintenance and Inspection — Training Issues. November 1990. Washington, D.C.
- Taylor, J.C. (1989). "Allies in Maintenance: The Impact of Organizational Roles on Maintenance Programs". Proceedings of the Second Annual International Conference on Aging Aircraft (pp. 221-225). Washington, D.C. Federal Aviation Administration.
- Taylor, J.C. "Facilitation of Information Exchange Among Organizational Units Within Industry". Proceedings of the Second Federal Aviation Administration Meeting on Human Factors Issues in Maintenance and



- Inspection — Information Exchange and Communication. May 1990. Washington, D.C.
- Taylor, J.C. "Organizational Context in Aviation Maintenance — Some Preliminary Findings". Proceedings of the Third Federal Aviation Administration Meeting on Human Factors Issues in Aircraft Maintenance and Inspection — Training Issues. November 1990. Washington, D.C.
- Tepas, D.I. "Factors Affecting Shift Workers". Proceedings of the Fifth Federal Aviation Administration Meeting on Human Factors Issues in Aircraft Maintenance and Inspection — The Work Environment in Aviation Maintenance. January 1992. Washington, D.C.
- Thackray, R.I. (1992). "Human Factors Evaluation of the Work Environment of Operators Engaged in the Inspection and Repair of Aging Aircraft" (Report No. DOT/FAA/AM-92/3). Washington, D.C. Federal Aviation Administration.
- United States Congress Office of Technology Assessment (1988). "Safe Skies for Tomorrow: Aviation Safety in a Competitive Environment" (OTA-SET-381). Washington, D.C. U.S. Government Printing Office.
- Wiener, E.L. (1975). *Individual and Group Differences in Inspection*. In Drury, C.G. (Ed.), *Human Reliability in Quality Control*, pp. 19-30. London: Taylor & Francis.
- Wiener, E.L. "Vigilance and Inspection Performance". Proceedings of the First Federal Aviation Administration Meeting on Human Factors Issues in Aircraft Maintenance and Inspection. October 1989. Washington, D.C.
- Woods, D.D. (1989). *Coping with complexity: The Psychology of Human Behaviour in Complex Systems*. In Goodstein, L.P., H.B. Anderson and S.E. Olsen (Eds.), *Tasks, Errors and Mental Models*, London: Taylor and Francis, 128-148.
-

**PART 2**

**TRAINING PROGRAMMES FOR  
OPERATIONAL PERSONNEL**

## Chapter 1

# BASIC HUMAN PERFORMANCE TRAINING PROGRAMMES FOR OPERATIONAL PERSONNEL

### 1.1 INTRODUCTION

1.1.1 Although shortcomings in human performance are the predominant factor contributing to aviation accidents and incidents, it has never been clear what aspects of human capabilities and limitations should — or could — be addressed by training. On the other hand, it has been equally clear for some years that Human Factors education and training within the aviation system could be improved. The purpose of this chapter is to introduce and review the design and content of training courses in aviation Human Factors. It is directed to those having responsibility for the development and implementation of human performance training courses for operational personnel, and includes the following:

- a) outline ICAO training syllabi for human performance training for pilots, air traffic controllers and maintenance technicians;
- b) a brief commentary on various problems associated with initiating aviation human performance training;
- c) information for States, training establishments and instructors to assist in the development of suitable training syllabi and materials;
- d) a discussion of issues which arise when considering the content and presentation of human performance training; and
- e) samples of human performance training courses already in use, or under development.

1.1.2 The production of this chapter, and much of its content, has been influenced by progressive changes to ICAO Annex 1 — *Personnel Licensing*, which became applicable in November 1989 (Eighth Edition) and November 2001 (Ninth Edition), and to Annex 6 —

*Operation of Aircraft*, Part I, which became applicable in November 1995 (Sixth Edition) and November 1998 (Seventh Edition). These changes relate to human performance training requirements in respect of operational personnel licensing; their importance is discussed in 1.1.1. However, the approach taken in this chapter anticipates a continuing progress in human performance training; it therefore addresses the subject in a manner which goes beyond a narrow interpretation of the training needs dictated by the Annexes' revisions.

1.1.3 The ICAO approach to Human Factors has been outlined in Part 1, Chapters 1 and 2 of this manual. This present chapter, which builds upon the contents of Part 1, has pilot and air traffic controller training as its primary focus but should be equally helpful when considering the needs of other operational personnel, including maintenance technicians and flight dispatchers. Additional information relevant to applied skills training in some specific aspects of Human Factors is contained in Part 2, Chapter 2, of this manual: *Crew Resource Management (CRM) Training*. This chapter is mainly directed towards meeting the human performance knowledge requirements specified in Annex 1 and Annex 6, Part I.

1.1.4 This chapter:

- introduces the subject of Human Factors in the context of the operational personnel training requirements of Annex 1;
- provides sample human performance curricula which States and training establishments may wish to consult when designing their own training courses. The training discussed in this chapter is not intended as a substitute for training aimed at improving operational Human Factors skills, such as Crew Resource Management (CRM) or Team Resource Management (TRM) training. Rather, the ICAO syllabi supplement such skills-based training

and, since they particularly address basic knowledge, preferably should precede it;

- provides the rationale and basic information which interested States might take into account when selecting instructors and developing and implementing their own training courses; and
- provides examples of syllabi currently in use, or under development.

1.1.5 As a result of the changes to Annex 1 and Annex 6, human performance training for operational personnel is undergoing continuous development, with widespread consensus on the content of appropriate training courses, and an ongoing evolution in training substance and methods.

1.1.6 This chapter is written in a manner intended to offer the maximum possible assistance to all those having responsibility for human performance training, regardless of their positions. Because the needs of administrations, operators, training establishments and individual instructors may vary widely within a State or from State to State, however, the chapter's contents should be interpreted accordingly.

## 1.2 HUMAN FACTORS TRAINING FOR OPERATIONAL PERSONNEL: AN INTRODUCTION AND OVERVIEW

### Background and justification

1.2.1 Apart from the impact of shortcomings in human performance upon aviation safety, an important reason for the development of this particular chapter was the publication of the Eighth Edition of Annex 1 — *Personnel Licensing*, which became applicable in November 1989 and the Sixth Edition of Annex 6 — *Operation of Aircraft*, Part I, which became applicable in November 1995. As of 1989, all subsequent editions of Annex 1 contain a Human Factors knowledge requirement for each category of licence holder or function, namely:

“... human performance relevant to [the licence being issued or the function being discharged]”.

The Ninth Edition of Annex 1 (July 2001) and the Eighth Edition of Annex 6 (July 2001) define “human performance” as: “Human capabilities and limitations which have

an impact on the safety and efficiency of aeronautical operations”.

This knowledge requirement has the same status as knowledge required in respect of meteorology, navigation, principles of flight, or any other part of the traditional training syllabus. It therefore necessitates the production of an appropriate training syllabus and the integration of new training concepts into the conventional training syllabus.

1.2.2 Furthermore, in Annexes 1 and 6, Part I, for some licences and/or functions the requirement for demonstration of skill includes certain elements of human performance. Examples of these and other human performance-related provisions from the Annexes are presented in Table 1-1.

1.2.3 The Eighth Edition of Annex 6 (July 2001) defines “Human Factors principles” as: “Principles which apply to aeronautical design, certification, training, operations and maintenance and which seek safe interface between the human and other system components by proper consideration to human performance”.

1.2.4 In addition to the provisions mandated in Annexes 1 and 6, Part I, additional impetus for change has come from safety experts within the aviation industry. The participation of such experts in research and accident/incident investigation has been steadily growing. In addition to the immediate effect of their published findings, such experts have played an important role in identifying potential solutions to various Human Factors safety and training deficiencies.

1.2.5 The publication of the Eighth Edition of Annex 1 and the Sixth Edition of Annex 6, Part I, and the progressive expansion of Human Factors related provisions in subsequent editions, confirmed a growing international consensus that training in aviation Human Factors is a necessity. This chapter is a response to the consequent need for training materials.

## 1.3 THE PRIOR SITUATION

1.3.1 As long as human beings are part of the aviation system, human capabilities and limitations will influence safety. It comes as no surprise that the consequences of shortcomings in human performance have been well identified in accident reports and other publications. International licensing requirements, the design of equipment, training and operational procedures and the investigation of

**Table 1-1. Human performance-related provisions from Annexes 1 and 6.**

<i>Source</i>	<i>Applicable to</i>	<i>Text</i>	<i>Reference</i>
Annex 1	ATPL licence (skill)	Understand and apply crew coordination and incapacitation procedures.	2.5.1.5.1.1 f)
Annex 1	ATPL licence (skill)	Communicate effectively with the other flight crew members.	2.5.1.5.1.1 g)
Annex 1	Flight engineer licence (skill)	Communicate effectively with the other flight crew members.	3.3.4.1 e)
Annex 6	Flight operations	The design and utilization of checklists shall observe Human Factors principles.	4.2.5
Annex 6	Flight crew member training programmes	The training programme shall also include training in knowledge and skills related to human performance and in the transport of dangerous goods.	9.3.1
Annex 6	Cabin crew training programmes	These training programmes shall ensure that each person is: (...) knowledgeable about human performance as related to passenger cabin safety duties including flight crew-cabin crew coordination.	12.4 f)
Annex 6	Operations manual	Information on the operator's training programme for the development of knowledge and skills related to human performance.	Appendix 2, Item 15

accidents and incidents are amongst those elements of the aviation system which have changed steadily as a result of such experience.

1.3.2 Change, however, was both slow and piecemeal. There were disparate understandings of Human Factors within the aviation community. Limitations in the state of knowledge about the nature of human capabilities and limitations in aviation resulted in a somewhat incoherent and incomplete approach to Human Factors training in the past.

1.3.3 With respect to operational personnel training, there was a similar diversity of strategies responding to Human Factors problems. These strategies ranged from dedicated training courses in Human Factors aimed exclusively at factual knowledge, through to training focused exclusively on the development of specific skills, such as communications, crew coordination, resource management and decision making.

1.3.4 These solutions were limited by being only partially implemented, as well as by a lack of both national and international coordination. Developments within Contracting States have led to the publication of national regulatory requirements and guidance material on the subject of Crew Resource Management training. This is one of many national safety initiatives which have addressed the need for a uniform response to an identified aspect of human performance within the aviation system.

## 1.4 HUMAN FACTORS HIGHLIGHTS

1.4.1 The following paragraphs highlight a number of general Human Factors considerations, intended essentially as a summary of Part 1 of this manual which, ideally, should be read before any training courses are developed.

### Human Factors: an overview

1.4.2 Human Factors is about people: it is about people in their working and living environments, and it is about their relationship with equipment, procedures and the environment. Just as importantly, it is about their relationships with other people. Human Factors involves the overall performance of human beings within the aviation system; it seeks to optimize people's performance through the systematic application of the human sciences, often integrated within the framework of system engineering. Its twin objectives can be seen as safety and efficiency. Human Factors is essentially a multidisciplinary field, including but not limited to: psychology, engineering, physiology, sociology and anthropometry (see Table 1-2).

1.4.3 Human Factors has come to be concerned with diverse elements in the aviation system. These include human behaviour and performance; decision making and other cognitive processes; the design of controls and displays; flight deck and cabin layout; communication and software aspects of computers; maps, charts and

**Table 1-2. Disciplines frequently involved in Human Factors activities\***

<i>Discipline</i>	<i>Definition</i>	<i>Specific area of interest</i>	<i>Typical area of application</i>
Psychology	The science of mind and behaviour.	Sensory characteristics, perceptual laws, learning principles, information processing, motivation, emotion, research methods, psychomotor skills, human errors.	Display requirements and design, control systems design, allocation of function, training system requirements and methods, selection methods, effects of emotional and environmental stress on performance, simulation requirements.
Engineering	Applying the properties of matter and the sources of energy in nature to the uses of man.	Hydraulics, mechanical, structural, electrical, electronic, and aerodynamics design, systems analysis, simulation, optics.	Design of displays, design of controls, design of control systems, design of complex systems, design of optical systems, simulator design.
Human physiology	Deals with the processes, activities and phenomena characteristic of living matter, particularly appropriate to healthy or normal functioning.	Cell structure and chemistry, organ structure and chemistry, interaction of the various body constituents to promote health and function, functions and requirements of body systems.	Environmental systems, diet and nutrition, effects of environmental factors (heat, cold, hypoxia), establishment of environmental requirements.
Medicine	The science and art of preventing, alleviating or curing disease and injuries.	Effects of various forces, radiation, chemical and disease agents; appropriate preventive methods of protecting health and well-being.	Toxicology of smoke, chemicals, impact protection, maintenance of health.
Sociology	The study of the development, structure and function of human groups.	Small and large groups or "teams"; crew composition; behaviour of passengers in emergency situations.	Crew selection, passenger safety.
Anthropometry	Study of human body sizes and muscle strength.	Anatomy, biodynamics, kinesiology.	Ground support equipment, access door size for maintenance, work station layout (reach, range of adjustment of seats, etc.)

\* *Other disciplines with representatives actively engaged in Human Factors activities include education, physics, biochemistry, mathematics, biology, industrial design and operations research.*

documentation; and the refinement of training. Each of these aspects demands skilled and effective human performance.

1.4.4 Given the contemporary emphasis upon the social sciences within Human Factors, it should be remembered that physiology is among the many other important sources of Human Factors knowledge. Thus, for example, anthropometry and biomechanics — involving measurements and movements of the human body — are relevant to the design of the workplace and to the equipment therein; similarly, biology and its subdiscipline, chronobiology, are necessary for an understanding of those bodily rhythms which influence human performance.

1.4.5 In spite of the academic sources of information on the various Human Factors disciplines, aviation Human

Factors is primarily oriented towards solving practical problems in the real world. As a concept, its relationship to the human sciences might well be likened to that of engineering to the physical sciences. And, just as technology links the physical sciences to various engineering applications, there are a growing number of integrated Human Factors techniques or methods; these varied and developing techniques can be applied to problems as diverse as accident investigation and the optimization of pilot training.

#### **Accidents and incidents**

1.4.6 Human error is, by far, the most pervasive contributing factor to accidents and incidents in

technologically complex systems such as air transportation. One major data base of jet transport accidents worldwide indicates that 65 per cent of all such accidents have been attributed to flight crew error. It also indicates that for the approach and landing phases of flight, which account for 4 per cent of total flight exposure time and 49 per cent of all accidents, flight crew error is cited in 80 per cent of cases as a causal factor. Other sources of human error, including maintenance, dispatch and, importantly, air traffic control, account for another significant proportion of accidents. Towards the end of the 20th century, the study of human error broadened to include the influence of senior, high-level management performance on aviation safety.

1.4.7 It must be kept in mind that accidents involving commercial jet transport are only the tip of the iceberg; numerous fatalities occur each year in general aviation alone. Studies have shown that human performance is involved as a contributing factor in nearly 90 per cent of these accidents, making it abundantly clear that human performance is the critical and enduring issue facing those who have responsibility for the design, operation and supervision of our aviation system. The solution of these long-standing Human Factors problems is therefore essential.

1.4.8 It is most important that all concerned with the operation and administration of the aviation system recognize that, no matter how determined the effort to prevent it may be, human error will have an impact on the system. No person, whether designer, engineer, manager, controller or pilot, can perform perfectly at all times. Also, what could be considered perfect performance in one set of circumstances might well be unacceptable in another. Thus, people need to be seen as they really are; to wish that they be intrinsically "better" or "different" is futile, unless such a wish is backed by a recommendation for remedial action, which itself must be further supplemented by the provision of means to achieve better design, training, education, experience, motivation, etc., with the objective of positively influencing relevant aspects of human performance.

1.4.9 The ICAO Human Factors Training Manual is intended as a source of both information and practical measures to be used in the effort to improve education, training and remedial measures in Human Factors. The brief review above sets the context for the detailed consideration of Human Factors.

## 1.5 THE SHEL MODEL

1.5.1 No discussion of constituents can capture the essence of the various processes and interactions that

characterize an operational system. One objective of Part 1 of this manual is to identify the many and varied topics in Human Factors so as to describe their different operational implications. It was also necessary to find a way of describing the various processes of control, information exchange, etc., which occur in practice. To achieve these objectives, ICAO introduced the "SHEL" model (see Figure 1-1).

1.5.2 The SHEL model provides a conceptual framework to help understand Human Factors. It illustrates the various constituents and the interfaces — or points of interaction — which comprise the subject. Human Factors elements can be divided into four basic conceptual categories:

*Software:* documentation, procedures, symbols, etc.

*Hardware:* machinery, equipment, etc.

*Environment:* both internal and external to the workplace

*Liveware:* the human element.

Interactions between human beings and the other elements of the SHEL model are at the heart of Human Factors, which involves the interfaces between:

— humans and machines — "Liveware-Hardware"

— humans and materials — "Liveware-Software"

— humans and their colleagues — "Liveware-Liveware"

— humans and the operating environment — "Liveware-Environment".

The SHEL model provides the structure around which the syllabus in 1.7 was developed and written. With use, the advantages of this model in guiding instruction on Human Factors should also become clear.

## 1.6 THE IMPLICATIONS OF THE PROVISIONS FROM ANNEXES 1 AND 6, PART I

1.6.1 The ICAO licensing/training Human Factors requirements may present some problems for training institutions, airlines, ATS providers and licensing authorities. In the case of operational personnel technical training, for instance, there has been a long-standing, wide international

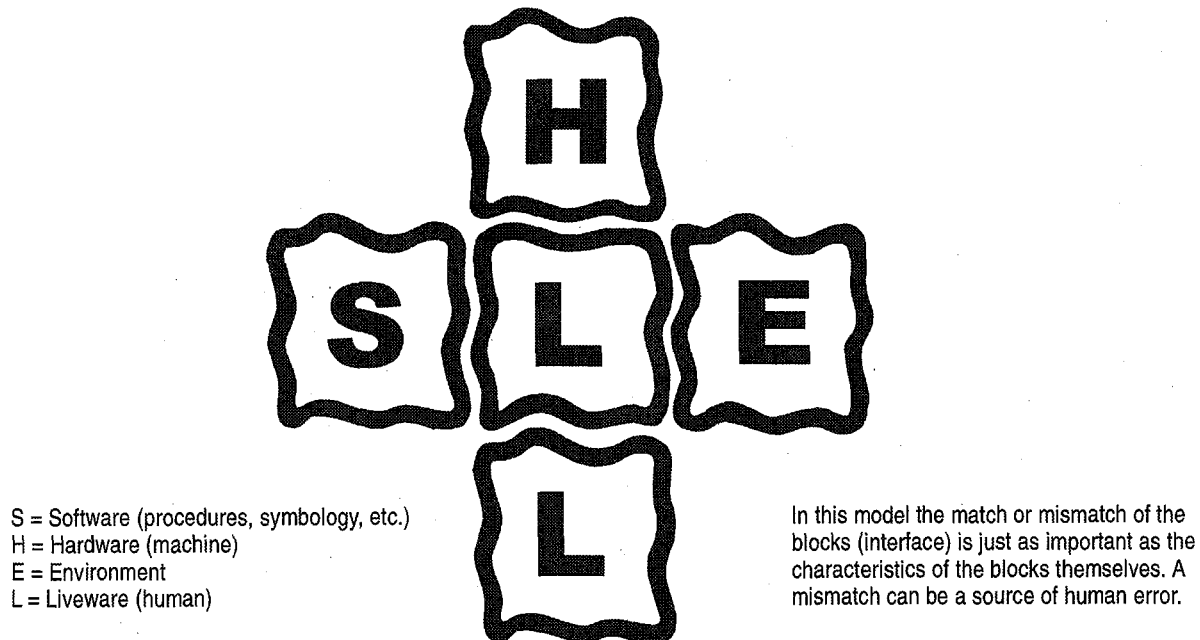

Figure 1-1. The SHEL Model.

consensus as to training requirements, methods, objectives and course content. Guidance material is readily available, syllabi are easy to develop, and training methods are well established. However, a similar consensus as to the appropriate focus for training in aviation Human Factors is of a more recent date.

1.6.2 There are different perspectives in this matter. A central problem for many States is the difference in international practices regarding the application to such training of physiology, ergonomics, and the social/behavioural sciences. Further differences relate to the relative importance accorded to knowledge and skills training. Perspectives on training content and strategies can be strongly influenced by different cultural and social practices.

1.6.3 While ICAO regulations serve to promote common international Standards and Recommended Practices, some international differences remain in the practical achievement of various ICAO requirements. For instance, in some countries the predominant pilot training and licensing emphasis is directed at the individual licence

holder, while in others the maintenance of standards is primarily addressed through the airline operator. In the former States, much thought tends to be given to the training and checking of individual pilots, while in the latter it is the industry operating practices and procedures which receive greater attention.

1.6.4 Associated with these perspectives are different approaches to aviation safety problems. Some specialists favour a broad, industry-wide systems approach to analysis and remedial action, while others prefer to focus on specific problem areas. Some authorities believe that the most effective action takes place at the point of aircraft and procedural design, and thus feel that any action at the level of individual operational personnel is misplaced. Others see line management within the aviation industry as providing an appropriate focus for implementation of change. Thus, airline operators vary considerably in the practical emphasis they allocate to operational aspects of Human Factors.

1.6.5 In many countries further problems derive from a lack of suitable resources, including appropriately trained specialists, managers and legislators (see also 1.12.5



regarding instructor qualification and selection). Furthermore, some national authorities are proactive in pursuit of their regulatory activities, while others are not.

1.6.6 In spite of these possible sources of difficulty, given the need to respond to ICAO's provisions for operational personnel knowledge and skill requirements in human performance, the industry must move forward. While there remain undoubtedly some significant and difficult decisions to be made, the development of appropriate training courses has become an accepted need in the industry.

## 1.7 HUMAN PERFORMANCE TRAINING CURRICULUM: AN ICAO PROPOSAL

### General

This section identifies specific areas of knowledge to be included in the design of human performance training programmes. Annex 1 provides that the licence holder shall demonstrate knowledge on human performance commensurate with the type and level of the licence (PPL, CPL, ATPL, air traffic controller, maintenance engineer, etc.). In order to comply with this requirement, specific programmes should be designed for each type and level of licence. For the purpose of this document, however, and in order not to make this proposal too binding, a single programme for pilots is proposed as a baseline, with differences in its applicability to different levels of licence to be made as appropriate. A programme for air traffic controllers is also proposed.

## 1.8 HUMAN PERFORMANCE TRAINING CURRICULUM FOR PILOTS

### The knowledge requirement

1.8.1 The outline curriculum provided below meets the training requirements for the airline transport pilot licence (ATPL) holder; with minor adjustments it can easily be made applicable to the commercial pilot licence (CPL), to the instructor/instrument ratings and to the private pilot licence (PPL).

1.8.2 A general survey within the industry indicates that approximately 35 hours is the time required to properly

present human performance training similar to that in the proposed syllabus. The minimum is estimated to be 20 hours. In order to provide an indication of the relative importance of each topic, the following indicates the percentages of total time to be given to each subject:

Module Title	Time
1 Introduction to Human Factors in aviation	5% (1.75 hrs)
2 The Human Element (Aviation physiology)	10% (3.5 hrs)
3 The Human Element (Aviation psychology)	10% (3.5 hrs)
4 Liveware-Hardware: Pilot-equipment relationship	15% (4.75 hrs)
5 Liveware-Software: Pilot-software relationship	10% (3.5 hrs)
6 Liveware-Liveware: Interpersonal relations	20% (7.0 hrs)
7 Liveware-Environment: The organizational environment	30% (10.5 hrs)
	Total: 35 hours

1.8.3 Whatever the total amount of hours allocated to any given programme, a balanced introduction to human performance training should be achieved if these relative percentages are applied. Given this general guidance, any aviation Human Factors specialists involved in course development should be able to provide advice on appropriate course content. The following outline is therefore not intended to be exhaustive, but it will provide guidance to the specialist in the development of a satisfactory course.

### Module 1: Introduction to Human Factors in Aviation

In this module, the rationale for Human Factors training should be explained. A good point of departure is the graph from Boeing (Figure 1-2) that shows the accident rate of commercial jet aircraft per million departures, from 1959–2002, in which are also projected the accident rates on the expected growth figures for aviation until 2021, as included hereunder.

The introduction has to be carefully prepared in order to capture the pilot's interest. It is desirable that training directed at meeting any examination or test requirement associated with the revised Annex 1 be kept relevant to operational aspects of flight. A practical orientation is therefore essential to effective training. The relevance of

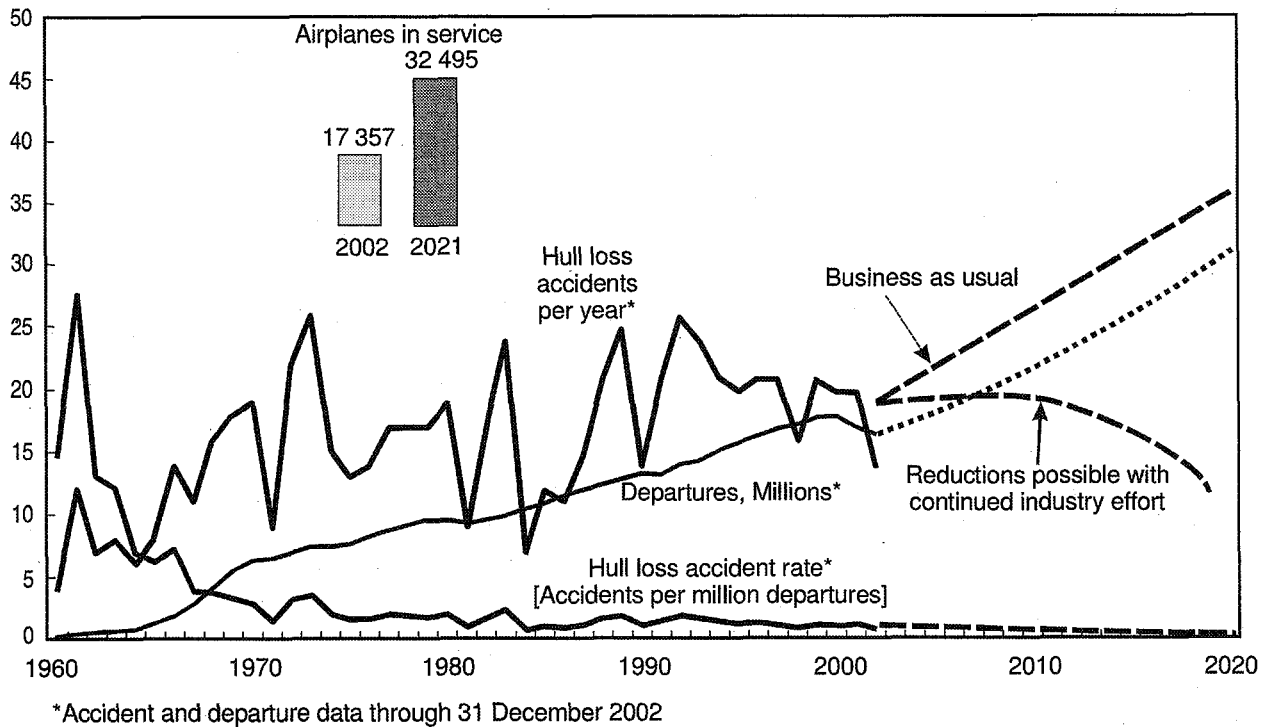

Source: Boeing

Figure 1-2. Accident rate of commercial jet aircraft per million departures

the programme must be made quite clear to pilots — this is not intended as an academic exercise. Therefore, only that information which relates to pilot performance should be included. Training personnel should present the information according to their particular operational needs and may wish to take specific aspects of their local accident/incident experience into account.

The SHEL model might be usefully introduced in this module as one of the possible aids to understanding the interactions between the different components of the system, as well as the potential for conflict and error arising from the various mismatches which can occur in practice.

A second model which might also be considered useful for introduction is the Reason model (see Part 1, Chapter 4 or Chapter 2) for the analysis of the breakdown of complex socio-technological systems.

## Module 2: The Human Element (Aviation Physiology)

Breathing; recognizing and coping with:

- hypoxia
- hyperventilation

Pressure effects; effects on ears, sinuses and closed cavities of:

- trapped or evolved gases
- decompression
- underwater diving

Limitations of the senses

- visual
- aural
- vestibular
- proprioceptive
- tactile

Acceleration effects; positive and negative "G's"  
— aggravating conditions

Disorientation  
— visual illusions  
— vestibular illusions  
— coping mechanisms

Fatigue/alertness  
— acute  
— chronic  
— the effects on skill and performance

Sleep disturbances and deficits

Circadian dysrhythmia/jet lag

Personal health  
Effects of:  
— diet/nutrition  
— alcohol  
— drugs (including nicotine/caffeine)  
— medications (prescribed; over-the-counter)  
— blood donations  
— aging

Psychological fitness/stress management

Pregnancy

### Module 3: The Human Element (Aviation Psychology)

Human error and human reliability

Workload (attention and information processing)  
— perceptual  
— cognitive

Information processing  
— mind set and habit patterns  
— attention and vigilance  
— perceptual limitations  
— memory

Attitudinal factors  
— personality  
— motivation  
— boredom and complacency  
— culture

Perceptual and situational awareness

Judgement and decision making

Stress  
— symptoms and effects  
— coping mechanisms

Skills/experience/currency vs. proficiency.

### Module 4: Liveware-Hardware: Pilot-equipment Relationship

Controls and displays  
— design (movement, size, scales, colour, illumination, etc.)  
— common errors in interpretation and control  
— "glass" cockpits; information selection  
— habit patterns interference/design standardization

Alerting and warning systems  
— appropriate selection and set-up  
— false indications  
— distractions and response

Personal comfort  
— temperature, illumination, etc.  
— adjustment of seat position and controls

Cockpit visibility and eye-reference position

Motor workload.

### Module 5: Liveware-Software: Pilot-software Relationship

Standard operating procedures  
— rationale  
— benefits  
— derivation from human limitations and the accident/incident record

Written materials/software  
— errors in the interpretation and use of maps/charts  
— design principles and correct use of checklists and manuals  
— the four Ps

Operational aspects of automation  
— overload/underload and phase of flight; complacency and boredom  
— staying in the loop/situational awareness  
— automated in-flight equipment; appropriate use, effective task allocation, maintenance of basic flying skills.

## Module 6: Liveware-Liveware: Interpersonal Relations

*Note.— Liveware-Liveware deals with interpersonal contacts happening at the present time (here and now), as opposed to the interpersonal contacts involving people outside of the current operating situation (the latter are considered in Module 7).*

Factors influencing verbal and non-verbal communication between and with:

- flight deck crew
- cabin crew
- maintenance personnel
- company management/flight operations control
- air traffic services
- passengers

How verbal and non-verbal communication affects information transfer and thus safety and efficiency of flight.

Crew problem solving and decision making.

Introduction to small group dynamics/crew management (see also Chapter 2 for further information on this topic).

## Module 7: Liveware-Environment: The Organizational Environment

- A systemic view of safety
- The aviation system: components
- General models of organizational safety
- Organizational structures and safety
- Culture and safety
- Procedures and safety
- Safe and unsafe organizations.

### 1.9 THE SKILL REQUIREMENT

1.9.1 While the initial emphasis in human performance training should be upon knowledge and comprehension of basic Human Factors, instructors must also bear in mind the need to develop appropriate operational behaviour and skills. In other words, to make this academic knowledge useful, pilots must develop those skills and attitudes necessary to maximize their operational performance. For example, a pilot with proper knowledge of physiology should be able to identify an unfit condition with potentially dangerous and undesirable consequences and elect not to fly, thus exercising what can be considered as a judgement skill. Obviously, training activities directed

towards the development of suitable attitudes and skills should always be given the highest possible priority.

1.9.2 The following is a list of Human Factors skills areas identified using the SHELL model (some skills are of necessity included in more than one interface). This guidance material may assist trainers with the identification of the required Human Factors skills, and should help to fill the void between the written word and its practical application. Possible skills areas for training development are:

#### Liveware-Liveware (L-L)

- Communication skills
- Listening skills
- Observation skills
- Operational management skills; leadership and followership
- Problem solving
- Decision making

#### Liveware-Hardware (L-H)

- Scanning
- Detection
- Decision making
- Cockpit adjustment
- Instrument interpretation/situational awareness
- Manual dexterity
- Selection of alternative procedures
- Reaction to breakdowns/failures/defects
- Emergency warnings
- Workload; physical, allocation of tasks
- Vigilance

#### Liveware-Environment (L-E)

- Adaptation
- Observation
- Situational awareness
- Stress management
- Risk management
- Prioritization and attention management
- Coping/emotional control
- Decision making

#### Liveware-Software (L-S)

- Computer literacy
- Self-discipline and procedural behaviour
- Interpretation
- Time management
- Self-motivation
- Task allocation

The proposed ICAO curriculum detailed above includes an interface not considered as such in the SHELL model,

namely the Human Element. Human Factors skills under this heading include those relating to the psychological state and well-being of operational personnel themselves (this should not be confused with the "Liveware-Liveware" interface, which deals with interpersonal contacts):

#### The Human Element

Recognition/coping: disorientation (motion systems), stress  
 Fatigue  
 Pressure effects  
 Self-discipline/control  
 Perception  
 Attitudes and the application of knowledge and exercise of judgement

1.9.3 It will be readily appreciated from the foregoing that the development of skills for practical application during flight operations is an important evolution from theoretical Human Factors knowledge to actual operational settings. While the emphasis in this chapter is necessarily directed mainly toward pure knowledge requirements, it is important to reiterate that, where possible, practical Human Factors considerations should be built into all relevant aspects of instructional activity. This should apply throughout all stages of pilot and instructor training. Instruction directed at the acquisition of Human Factors skills is the activity which is expected to yield the greatest benefits in the future.

*Recommended reading: Line Operations Safety Audit (LOSA) (ICAO Doc 9803).*

*Human Factors Guidelines for Safety Audits Manual (ICAO Doc 9806).*

### 1.10 HUMAN PERFORMANCE TRAINING CURRICULUM FOR AIR TRAFFIC CONTROLLERS

#### General

1.10.1 This proposal identifies specific areas of knowledge to be included in the design of human performance training programmes for Air Traffic Controllers. Annex 1 provides that the licence holder shall demonstrate knowledge on "human performance relevant to Air Traffic Control". It does not differentiate in the level of required

knowledge for any ATC rating, although it could be argued that the programme for a Procedural Area Controller probably would not have to contain all items from that for a Radar Approach Controller, and vice versa.

1.10.2 Just as for each level of pilot licences, specific programmes should be designed for each ATC rating. For the purpose of this section, however, and in order not to make this proposal too binding, a single programme is presented as a baseline, with differences in its applicability to different levels of licences/ratings to be made as appropriate.

#### The knowledge requirement

1.10.3 A general survey within the industry indicates that approximately 35 hours is the time required to properly present Human Factors training similar to that in the proposed syllabus. The minimum is estimated to be 20 hours. In order to provide an indication of the relative importance of each topic, the following indicates the percentages of total time to be given to each subject:

Module	Title	Time
1	Introduction to Human Factors in aviation	5% (1.75 hrs)
2	The Human Element (Aviation physiology)	10% (3.5 hrs)
3	The Human Element (Aviation psychology)	10% (3.5 hrs)
4	Liveware-Hardware: Controller-equipment relationship	15% (4.75 hrs)
5	Liveware-Software: Controller-software relationship	10% (3.5 hrs)
6	Liveware-Liveware: Interpersonal relations	20% (7.0 hrs)
7	Liveware-Environment: The organizational environment	30% (10.5 hrs)
		Total: 35 hours

1.10.4 Whatever the total amount of hours allocated to any given programme, a balanced introduction to human performance training should be achieved if these relative percentages are applied. Given this general guidance, any aviation Human Factors specialists involved in course development should be able to provide advice on appropriate course content. The following outline is therefore not intended to be exhaustive, but it will provide guidance to the specialist in the development of a satisfactory course.

1.10.5 It is important to realize that this outline is designed for *ab initio* training. For the training of already qualified ATC personnel, a different programme needs to be designed. Such a programme should take into consideration the existing level of operational experience of the target group. Both programme types should contain elements of Team Resource Management (TRM) training and Threat and Error Management (TEM) training.

*Note.— TRM and TEM are discussed in Part 1, Chapter 5 of this manual.*

### Module 1: Introduction to Human Factors in Aviation

In this module, the rationale for human performance training should be explained. A good point of departure is the graph from Boeing (Figure 1-2) that shows the accident rate of commercial jet aircraft per million departures, from 1959-2002, in which are also projected the latest accident rates on the expected growth figures for aviation until 2021, as included in paragraph 1.8.3.

As a next step, the SHEL model may be usefully introduced in this module as one of the possible aids to understanding the interactions between the different components of the system, as well as the potential for conflict and error arising from the various mismatches which can occur in practice. The model helps to answer the question: "What is Human Factors?"

It has been found highly illustrative to present *local* examples of the four possible types of interactions when introducing the SHEL model to Air Traffic Controllers.

A second model which might also be considered useful for introduction is the Reason model for the analysis of the breakdown of complex socio-technological systems.

The introduction has to be carefully prepared in order to capture the controllers' interest. It is desirable that training directed at meeting any examination or test requirement associated with Annex 1 be kept relevant to operational aspects of Air Traffic Control. A practical orientation is therefore essential to effective training. The relevance of the programme must be made quite clear to Air Traffic Controllers — *this is not intended as an academic exercise*. Therefore, only that information which relates to controller performance should be included. Training personnel should present the information according to their particular operational needs and are encouraged to take specific aspects of their local accident/incident experience into account.

### Module 2: The Human Element (Aviation Physiology)

This module may be divided into two sections. The first consists of physiological aspects affecting pilots, and thus possibly also affecting the interaction between pilot and controller. The second consists of physiological aspects of shift work.

Part one: pilots (refer to 1.8.3)

- Hypoxia
- Pressure effects
- Limitations of the senses
- Acceleration effects (positive/negative "G"s).  
(*N.B. This could be especially relevant for air traffic controllers handling military traffic.*)
- Disorientation
- Fatigue/alertness
- Sleep disturbances and deficits
- Circadian dysrhythmia/jet lag

Part two: air traffic controllers

Fatigue/alertness:

- Sleep disturbances and deficits
- Circadian dysrhythmia
- Nightshift paralysis
- Handling traffic peaks at the end of a long shift/use of rest breaks
- Social aspects of shift work.

### Module 3: The Human Element (Aviation Psychology)

Human error and human reliability:

Workload (attention and information processing)

- perceptual
- cognitive

*Recommended reading:* Part 1, Chapter 4, and Reason, J. *Managing the risks of organisational accidents.* (ISBN 1-84014-105-0).

Information processing:

- mindset and habit patterns
- attention and vigilance
- perceptual limitations
- memory

Attitudinal factors:

- personality
- motivation
- job satisfaction
- boredom and complacency

- culture
- individual versus team

*Recommended reading:* Kinney, G.C. *Effects of mental attitudes on the job performance of controllers and supervisors*. FAA Aeronautical Decision Making project. pre-1991, Part 1, Chapter 4 and Professor G. Hofstede: *Cultures and Organisations* (ISBN 0-07-707474-2).

Perception and situational awareness

Judgement and decision making

Stress:

- possible causes
- symptoms and effects
- coping mechanisms

Skills/experience/currency versus proficiency:

- possible loss of rating after not having worked operationally for a specified time

Personal health

Effects of:

- diet/nutrition
- alcohol
- drugs (including nicotine/caffeine)
- medications (prescribed; over-the-counter)
- blood donations
- aging/burn-out

Psychological fitness/stress management

- Critical Incident Stress Management (CISM)

*Note.— Much work on developing a CISM programme for ATC has been done in Canada and also by Eurocontrol (Ref. EATCHIP Human Factors Module "Critical Incident Stress Management" – HUM.ET1.ST13.3000-REP-01).*

Pregnancy

Retirement from operational ATC.

#### **Module 4: Liveware-Hardware: Controller-Equipment Relationship**

Displays

- flight progress strips
- VDUs
- use of colours
- radar/ADS

Alerting and warning systems (both airborne and ground-based)

(Examples: GPWS, TCAS [airborne], STCA [ground-based]):

- false indications (nuisance warnings)
- distractions and response

Personal comfort:

- temperature, illumination, humidity, etc.
- seat adjustment
- noise
- use of headset versus speaker

Console design:

- height/angle (ergometric design)
- colour of paintwork
- eye-reference position

*Recommended reading:* Part 1, Chapter 4.

#### **Module 5: Controller-Software Relationship**

Standard operating procedures:

- rationale
- benefits
- derivation from human limitations and the accident/incident record

Written materials/software:

- errors in the interpretation and use of maps/charts
- design principles and correct use of manuals and checklists

Operational aspects of automation:

- overload/underload; complacency and boredom
- staying in the loop/situational awareness
- automated ATC equipment; appropriate use; maintenance of "manual" skills; staffing consequences.

#### **Module 6: Liveware-Liveware: Interpersonal Relations**

*Note.— Liveware-Liveware deals with interpersonal contacts happening at the present time, as opposed to the interpersonal contacts involving people outside of the current operating situation (the latter are considered in Module 7).*

Factors influencing verbal and non-verbal communication between and with:

- other Air Traffic Controllers in the team (shift) and/or Ops-room
- coordination partners (other ATC units)
- pilots (R/T)
- maintenance personnel

- supervisors/management
- coach/trainee — On-the-Job Training (OJT)

How verbal and non-verbal communication affects information transfer and thus safety and efficiency.

Special emphasis on problems with native and non-native English speakers (both in R/T and inter-unit coordination).

Cultural differences:

- crews from foreign operators may have different expectations or be trained to react differently from what ATC would expect in certain situations. An example could be the case study on the crash of Avianca 052, New York, 1990. ("Anatomy of a system accident: Avianca Flight 052"; The International Journal of Aviation Psychology, 4 (3), 265-284 by Professor Robert Helmreich.)

*Recommended reading:* Professor G. Hofstede: *Cultures and Organisations* (ISBN 0-07-707474-2).

Pros and cons of data link communications:

- loss of non-verbal component of R/T
- input errors versus readback/hearback errors
- partyline effect

Team problem solving and decision making:

- principles of Team Resource Management (TRM)
- principles of Threat and Error Management (TEM)
- application of TEM and TRM techniques in ATC.

*Note.— TRM and TEM are discussed in Part 1, Chapter 5 of this manual.*

## Module 7: Liveware-Environment: The Organizational Environment

- A systemic view of safety
- The aviation system: components
- General models of organizational safety
- Organizational structures and safety
- Safety management in ATM
- Culture and safety
- Procedures and safety
- Safe and unsafe organizations.

*Recommended reading:* *Human Factors Guidelines for Air Traffic Management Systems* (ICAO Doc 9758), *Human Factors Guidelines for Safety Audits Manual* (ICAO Doc 9806), *Manual on Safety Management* (ICAO Doc in preparation).

## 1.11 HUMAN PERFORMANCE TRAINING FOR MAINTENANCE TECHNICIANS

Recommended guidance material:

*Human Factors Guidelines for Aircraft Maintenance Manual* (ICAO Doc 9824).

*Human Factors Guidelines for Safety Audits Manual* (ICAO Doc 9806.)

## 1.12 CONSIDERATIONS IN TRAINING IMPLEMENTATION AND CURRICULUM DEVELOPMENT

### Overview

1.12.1 To assist in making courseware design decisions and in planning training implementation, the following paragraphs identify essential elements of human performance training and educational tasks. An attempt has been made to respond to needs across the training spectrum, from those of the individual instructor to those of major training establishments. The discussion therefore avoids too restrictive a view as to how actual training courses might be conducted in practice.

### Determination of target audience

1.12.2 The curriculum, training objectives and training effort will vary for different categories of aviation personnel. Obviously, all personnel do not need the same knowledge or skills.

1.12.3 Among operational personnel — the prime focus of the ICAO initiative — it will be important to differentiate among the specific requirements of the different categories included in Annex 1 (private, commercial, ATPL, controller, maintenance engineer). For example, when developing pilot training courses, the categories to be considered include *ab initio*, general aviation, commercial, air carrier, management/supervisory and instructor pilots. States or organizations must also develop training for other operational categories such as aircraft maintenance personnel, air traffic controllers and flight operations officers.

1.12.4 Although only limited knowledge of Human Factors may be required for senior management, appropriate background information is widely considered to be



essential. Supervisory and other personnel will need specialist knowledge by virtue of their particular function. Thus, for instance, there will clearly be different knowledge and competency requirements for senior management, accident prevention/air safety officers, accident investigators, flight operations management/supervisory personnel, and supervisory flight instructors.

### **Selection of the trainers**

1.12.5 The selection and education of those who will administer training programmes in human performance have been a matter of concern in some States, perhaps because of the understandable idea that only a trained psychologist can deal with subjects related to human behaviour. In their daily activities, however, pilots and instructors deal with and teach, for example, subjects related to aerodynamics without being aeronautical engineers, to meteorology without being meteorologists, to powerplants without being mechanics, and so on. There is no reason why this line of reasoning cannot be applied to the teaching of human performance.

1.12.6 Within the aviation community, flight and ground instructors, ATCO, maintenance technician or dispatcher instructors are among the obvious individuals capable of teaching human performance. If flight and ground instructors are thoroughly familiar with the contents of the proposed programme — whether through formal training or self-education — they will be able to fulfil the training objectives. Part 1 is one useful starting point for instructors since it includes an extensive bibliography. Alternatively, specialists in the subject will be in a good position to teach human performance. However, it will then be important to ensure that these specialists are themselves able to relate their knowledge in a practical manner to the operational environment.

## **1.13 TRAINING PHILOSOPHY AND OBJECTIVES**

### **Introduction**

1.13.1 General issues for attention during course design and development are discussed in this section. It is intended that consideration of these issues will help to clarify desirable training goals and techniques.

### **Training philosophy**

1.13.2 Among the more important topics requiring attention here are:

- a) the roles to be given to theoretical and practical, or experiential, learning activities. This will prove to be a most important decision in practice, so clarity is essential;
- b) the integration of knowledge-based training into briefing, debriefing and practical exercises conducted during operational training; and
- c) the role of training activities which promote experiential learning (e.g. role-playing, line-oriented flight training, simulator training for ATC teams, etc.).

### **Training objectives**

1.13.3 Once the philosophical direction of the training has been established, the training objectives must be specified. These will influence the design of the training courseware and the priority accorded to Human Factors in briefing, debriefing and performance appraisal.

1.13.4 When determining training objectives, and instructor training activities, it is often useful to divide the learning task into appropriate sub-categories such as “memorizing”, “understanding”, “doing”, and “attitudinal aspects” and to identify the post-training competency, or command of the subject matter, expected of the trainees within each category. These four categories or domains of trainee competence may be characterized as follows:

- knowledge-based (memorization)
- comprehension-based (understanding)
- skill/technique-based (doing)
- attitude-based.

1.13.5 Knowledge covers factual knowledge and may include memorizing appropriate procedural information. Suitable teaching and assessment techniques are currently used in the theoretical and procedural training of operational personnel.

1.13.6 Comprehension of relevant general principles and theory is often essential in order to achieve

competency. This category will sometimes overlap with other categories.

1.13.7 Operational personnel are expected to acquire and display certain practical skills and techniques. Skills in any domain must be exercised in a suitable fashion, in the appropriate context and at the correct time. In aviation, psychomotor and procedural skills have traditionally received most attention; in the case of human performance training, some additional skills are necessary, such as the development of appropriate communications/team skills.

1.13.8 Attitudes play an important part in determining overall performance. Philosophical aspects relating to operational practices, desirable professional attributes, and dispositions conducive to professional performance can be considered under this heading. The process of corporate/professional induction and socialization can also be considered under this heading for those operators involved in the *ab initio* training of operational personnel. Attitudes have been strongly emphasized by a number of Human Factors specialists, who have noted the role of appropriate attitudes in sustaining and implementing safe and effective operational practices.

### Subject content

1.13.9 The outline syllabi contained in this chapter should provide an overview of essential subject matter, as well as a suitable point of departure for detailed syllabus development.

### Training materials, techniques and educational technologies

1.13.10 A division can be made here between training hardware, training strategies/techniques, and the actual training courseware. It is anticipated that the better human performance training courses will make creative and imaginative use of the available resources. Optimal training will address the Annex 1 requirement whilst giving appropriate emphasis to training the essential Human Factors skills.

### Training hardware

1.13.11 While simulators come immediately to mind, there are many other potentially useful training devices, such as part-task trainers, computer-based training equipment, as well as video cameras/recorders, interactive video, CD-ROMs, DVDs and other developing hardware.

### Training strategies and techniques

1.13.12 Associated with the new training hardware is an increasing differentiation of training methods, many of which utilize modern instructional technology. Thus, for instance, the merits of interactive media and the effectiveness of video feedback in training are now widely recognized.

1.13.13 At the other extreme, valuable learning experiences can arise from the use of case studies or simulation. While such activities depend on careful and time-consuming preparation, they are cheap and can be highly effective.

1.13.14 In educational practice there is a growing trend towards open and experiential learning, which addresses both individual and team skill development and training needs. For operational personnel training in human performance, some such learning is seen by most specialists as highly desirable, notably in areas as communications and team coordination skills. Indeed, it is the acquisition of necessary skills, rather than the mere demonstration of theoretical understanding, that is the desired objective of such training.

1.13.15 In achieving training objectives the value of multi-method training should be noted. This is a means of integrating individual training techniques into multi-method "integrated training technologies". These "integrated training technologies" comprise carefully designed training programmes which facilitate both individual and crew-centred learning. Operationally relevant experiential learning is promoted by the provision of extensive feedback, often using video recordings and other means to facilitate reflection and student-lead debriefing.

### Training courseware

1.13.16 The content of fully developed training courseware will clearly depend on training objectives, time, equipment and the available resources. It should, desirably, integrate training activities in the classroom and in the operational environment. Courseware should be prepared so as to explicitly include Human Factors points for consideration during briefing and debriefing. While the essential focus of Annex 1 is upon the provision of Human Factors knowledge, the training of preference will best achieve this when operational skills are also addressed during instructional design and development. The choices made at the courseware design stage will help to define the relevant instructor/trainee learning activities.

## 1.14 SKILL DEVELOPMENT, OPERATIONAL PERSONNEL ASSESSMENT AND TRAINING COURSE EVALUATION

1.14.1 Regular assessment is very much a part of aviation industry practice and provides one means of meeting standards and determining training effectiveness. Decisions as to suitable and productive means of operational personnel assessment will be an important influence in human performance courseware design. While traditional methods of assessment have unquestioned value in measuring factual knowledge and various aspects of comprehension, an alternative form of performance appraisal is generally considered essential when judging the efficacy of experiential learning activities. Experiential learning, such as that seen in the best LOFT/CRM and/or TRM programmes, cannot be optimized if formal assessment is conducted simultaneously with the training.

1.14.2 Furthermore, the general difficulty of evaluating the effectiveness of communications skills, CRM and similar training is well known. Indeed, the difficult issues addressed here arise regularly in discussion, both in terms of justifying the training effort and in evaluating the effectiveness of all such training courses.

1.14.3 On the other hand, skill acquisition in aviation has traditionally been achieved on the job or in the course of high-fidelity simulation. Skill assessment and associated operational techniques have traditionally been conducted in the same environment. However, notwithstanding the influence of current practice, the desire for formal assessment of Human Factors skills must always be counterbalanced by full consideration of any negative learning consequences which may arise from that very assessment.

1.14.4 In this context, it should be noted that training activities such as simulation and LOFT are considered to be especially good training techniques because they explicitly concentrate on the skill development needs of trainees, while avoiding the negative learning connotations associated with the checking/testing environment. While there may be no international consensus as to the best means of addressing the difficult issue of human performance training evaluation (and trainee performance appraisal), it is clearly important that the general issues discussed above are fully understood by trainers and instructional designers. Such an understanding will help prevent premature moves to assessment and testing in circumstances where they could prove counterproductive to longer term learning needs.

## 1.15 HUMAN PERFORMANCE TRAINING CURRICULUM FOR AIRCRAFT MAINTENANCE ENGINEERS

### General

1.15.1 This section provides information on the needs and objectives for training course designers regarding Human Factors training of maintenance organization personnel. Maintenance organizations vary widely in both scope and size; therefore, they must decide on the overall training objectives for each job and the level of skill or knowledge required, as appropriate.

1.15.2 The text of this section is adapted from Appendix B to Chapter 5 of the *Human Factors Guidelines for Aircraft Maintenance Manual* (ICAO Doc 9824).

### Target population

1.15.3 The categories of aircraft maintenance personnel employed by operators or Approved Maintenance Organizations (AMOs) who are required to have Human Factors training comprise the following:

- Management personnel (senior, middle and supervisory);
- Accident/incident investigators;
- Personnel who certify aircraft and components for release to service;
- Instructors for Human Factors and some technical topics;
- Planning and maintenance programme engineers;
- Aircraft Maintenance Engineers (AMEs) and mechanics;
- Quality personnel (Quality Assurance and Quality Control);
- Stores department staff;
- Purchasing department staff;
- Ground equipment operators; and
- Contract staff in any of the above categories.

In addition, the maintenance inspectors in the State aviation regulatory body require Human Factors training to a level at least equal to their counterparts in industry.

1.15.4 The training needs and objectives suggested in this section assume that trainees have training and experience in their specific job disciplines as follows:

- Managers and supervisors are experienced and have leadership and management training;
- Planners and engineers are very familiar with aircraft documentation and the working conditions and environments of personnel performing aircraft maintenance work;
- Instructors and trainers understand instructional techniques and have experience in the working environment where the subject is to be applied;
- Investigators and auditors have experience and training in identifying, recognizing and analysing problems or causal factors related to Human Factors;
- AMEs have technical training and experience on the aircraft or components that they maintain; and
- Inspectors from the State aviation regulatory body are experienced in their regulatory inspection tasks and understand the working conditions, the personnel and environment of the appropriate AMO, aircraft or component maintenance work.

### Training needs

1.15.5 The primary objective of Human Factors training is to give all the above categories of personnel an understanding of how and why error is avoided when maintenance work is being performed. Each category is exposed to, or creates the potential for, the risk of making an error. Human Factors training should therefore be adapted to suit the particular categories so that they can identify and avoid the potential opportunities for errors. Detailed training objectives are shown in Table 1-3. Specific training needs for the various categories of the target population identified above are listed in the following paragraphs.

1.15.6 Managers and supervisors require knowledge on how working conditions influence the performance of personnel who plan and perform maintenance work on aircraft and aircraft components. Managers and supervisors need to be able to apply this knowledge and understand how their decisions and behaviour influence the attitudes of the personnel in the organization and their ability to perform their work with the minimum risk of error. Aspects that are direct management responsibilities, e.g. capital investment, budgets and accounting, may seem distant from

where the actual work is done but, in fact, have a significant impact on the size and competence of the workforce and its ability to perform safe and reliable work.

1.15.7 Supervisors need to be aware of the local factors that present the potential for error. They should know how working conditions and the availability of correct tools and equipment can affect the attitude of the maintenance personnel and their approach to their work. Supervisors should be able to recognize and identify trends which indicate Human Factors-related risks.

1.15.8 Planners and engineers have a key role in the avoidance of Human Factors-related error. They must be able to write instruction documents that are not only technically correct but easy to read, understand and are not ambiguous or open to interpretation. They need to understand how their decisions, instructions, documents and other directives can influence the performance and results of work done on the aircraft or its components in workshops, hangars and ramp areas. It is therefore important that they understand the practical aspects of the work of maintenance personnel.

1.15.9 Instructors and trainers should ideally have a thorough understanding of the fundamentals of Human Factors as well as knowledge and experience from working in the particular environment (for example, workshops, hangars and ramp areas). They must be able to explain the fundamentals of Human Factors theory and possess theoretical knowledge to a level where they can illustrate with examples as well as facilitate discussions.

1.15.10 Investigators and auditors need to be able to identify, recognize and analyse problems or causal factors related to Human Factors. The investigator must be able to identify contributory Human Factors when investigating incidents. An auditor must be able to recognize potential Human Factors-related risks and report on these risks before they cause an error-related incident and become a subject for the investigator.

1.15.11 AMEs are the last link in the safety chain, and their training objectives are to understand why and how they may inadvertently create an unsafe condition when performing maintenance tasks. It must be possible for them to detect situations where there is the potential for making direct mistakes themselves. They must also be able to detect a built-in error in working instructions or information, and identify faulty equipment. They must understand how the working environment and one's own personal situation affects job performance.

1.15.12 Inspectors from the State aviation regulatory body need a similar level of knowledge as managers and supervisors.

### TRAINING OBJECTIVES AND LEVELS

1.15.13 Table 1-3 lists the training objectives for all categories of maintenance organization personnel. The levels of Human Factors skill, knowledge or attitude should be as follows (where Levels 2 and 3 assume that the objectives of earlier levels have been met):

*Level 1:* A familiarization with the principal elements of the subject. On completion of the training, a trainee should be able to meet the following objectives:

- Be familiar with the basic elements of the subject;
- Be able to give a simple description of the whole subject using everyday words and examples; and
- Be able to use typical Human Factors terms.

*Level 2:* A general knowledge of the theoretical and practical aspects of the subject. On completion of the training, a trainee should be able to meet the following objectives:

- Understand the theoretical fundamentals of the subject and be able to give a general description of the subject with typical examples;
- Read and understand literature describing the subject; and
- Be willing and able to apply Human Factors knowledge in a practical manner.

*Level 3:* A detailed knowledge of the theoretical and practical aspects of the subject. On completion of the training, a trainee should be able to meet the following objectives:

- Know and understand the theory of the subject and its interrelationships with other appropriate subjects;
- Be able to give detailed explanations of the subject using theoretical fundamentals and specific examples;
- Be willing and able to combine and apply subject knowledge in a logical, comprehensive and practical manner; and
- Be able to interpret results from various sources and apply corrective action as appropriate.

**Table 1-3. Training syllabus objectives**

*Note. The training syllabus objectives are listed under ten topic headings. Each topic is identified as follows:*

(S) = Skill;  
(K) = Knowledge; and  
(A) = Attitude.

1. General introduction to Human Factors:

- Achieve a basic understanding of the meaning of the term "Human Factors" (K).
- Recognize the contribution of Human Factors to aircraft accidents (K).
- Understand the goal of Human Factors training (K).
- Appreciate the need to understand and address Human Factors (A).
- Become reasonably familiar with some of the well-known incidents and studies of incident data where Human Factors have contributed. Understand why these incidents occurred (K).

2. Safety culture and organizational factors:

- Achieve a good understanding of the concept of "safety culture" (K).
- Understand the meaning of "organizational aspects of Human Factors" (K).
- Appreciate the importance of a good safety culture (A).
- Identify the elements of a good safety culture (K).

## 3. Human error:

- Appreciate that human error cannot be totally eliminated; it must be controlled (K).
- Understand the different types of errors and their implications, and avoiding and managing error (K).
- Recognize where the individual is most prone to error (K).
- Have an attitude likely to guard against error (A).
- Achieve a reasonable practical knowledge of the main error models and theories (K).
- Understand the main error types and how they differ from violations (K).
- Understand the different types and causes of violations (K).
- Avoid violating procedures and rules and strive towards eliminating situations which may provoke violations (A).
- Achieve a good understanding of well-known incidents in terms of errors leading towards the incidents (K).
- Appreciate that it is not errors themselves that are the problem but the consequences of the errors if undetected or uncorrected (A).
- Understand the different ways of reducing errors and mitigating their consequences (K).
- Have a basic understanding of the main Human Factors concepts and how these relate to risk assessment. Note: This has management applicability (K).

## 4. Human performance:

- Recognize the effect of physical limitations and environmental factors on human performance (K).
- Appreciate that humans are fallible (A).
- Achieve basic knowledge of when and where humans are vulnerable to error (K).
- Recognize where self or others suffer and ensure this does not jeopardize aviation safety(A).
- Understand how vision and visual limitations affect the trainee's job (K).
- Recognize the need to have adequate (corrected) vision for the task and circumstances (K).
- Be aware of the health and safety best practice regarding noise and hearing (K).
- Appreciate that hearing is not necessarily understanding (A).
- Obtain a basic familiarity with the key terms used to describe information processing (i.e.perception, attention and memory) (K).
- Achieve a basic understanding of the meaning of attention and perception (K).
- Understand the dimension of situational awareness (K).
- Develop ways of improving situational awareness (S).
- Achieve a basic understanding of the different types of memory (sensory, short-term, working, long-term) and how these may affect the person at work (K).
- Appreciate that memory is fallible and should not be relied upon (A).
- Appreciate that claustrophobia, fear of heights, etc., may affect the performance of some individuals (A).
- Understand what motivates and demotivates people in maintenance (K).
- Appreciate the need to avoid misdirected motivation (cutting corners) (A).
- Develop a willingness to admit when feeling unwell/unfit and take steps to ensure this does not affect the standard of work performed (A).
- Recognize the basic concepts and symptoms of stress (K).
- Develop different techniques and positive attitudes to cope with stress (S).
- Recognize the need to manage workload (K).
- Develop methods to manage workload (S).
- Understand how fatigue can affect performance especially with long hours or shift work(K).
- Develop ways of managing fatigue (S).
- Develop a personal integrity not to work on safety-critical tasks when unduly fatigued (A).
- Appreciate that alcohol, drugs and medication can affect performance (A).
- Understand the effects of sustained physical work on overall performance, especially cognitive performance in maintenance (K).
- Be aware of examples of incidents where repetitive tasks and complacency were a factor(K).
- Develop ways of avoiding complacency (S).

## 5. Environment:

- Achieve a basic appreciation of how the physical and social environment can affect human performance (K).
- Appreciate the importance of sticking to the "rules" even if others do not (A).
- Appreciate the importance of personal integrity (A).
- Appreciate the importance of avoiding placing peer pressure on others (A).
- Develop assertive behaviour appropriate to the job (S).
- Achieve a basic understanding of the concepts of stress and stressors as related to the maintenance environment (K).
- Recognize the dangers of cutting corners (K).
- Recognize the dangers of applying inappropriate deadlines (K).

- Recognize the dangers of self-imposed supervisor and manager time pressures (K).
- Understand the basic contributors to workload (K).
- Develop planning and organizing skills (S).
- Understand the basic concept of circadian rhythms as this relates to shift work (K).
- Be familiar with best practice regarding working hours and shift patterns (K).
- Develop strategies to manage shift work (S).
- Be aware of the health and safety guidance concerning noise and fumes (K).
- Be aware of the effects of lighting on performance (K).
- Be aware of the effects of climate and temperature on performance (K).
- Be aware of the health and safety guidance concerning motion and vibration (K).
- Be aware of the implications of own actions on other parts of the maintenance system (K).
- Be aware of the health and safety guidance concerning hazards in the workplace (K).
- Understand how to take into consideration the available manpower when scheduling, planning or performing a task (K).
- Develop ways of managing distractions and interruptions (S).

6. Procedures, information, tools and practices:

- Appreciate the importance of having available the appropriate tools and procedures (A).
- Appreciate the importance of using the appropriate tools and following the procedures (A).
- Appreciate the importance of checking work before signing it off (A).
- Appreciate the importance of reporting irregularities in procedures or documentation (A).
- Understand the factors that affect visual inspections (K).
- Develop skills to improve visual inspections (S).
- Appreciate the importance of correct logging and recording of work (A).
- Be aware that norms exist and that it can be dangerous to follow them (A).
- Be aware of instances where the procedures, practices or norms have been wrong (K).
- Appreciate the importance of having a good standard of technical documentation in terms of accessibility and quality (A).
- Learn how to write good procedures reflecting best practice (S).
- Learn how to validate procedures (S).

7. Communication:

- Recognize the need for effective communication at all levels and in all mediums (K).
- Understand the basic principles of communication (K).
- Develop skills, and correct verbal and written communication appropriate to the job and the context within which it is to be performed (S).
- Have detailed knowledge of some incidents where poor handover has been a contributory factor (K).
- Appreciate the importance of good handover (A).
- Learn how to carry out a good handover (S).
- Appreciate the importance of information being kept up to date and being accessible by those who need to use it (A).
- Appreciate that cultural differences can affect communication (A).

8. Teamwork:

- Understand the general principles of teamwork (K).
- Accept the benefits of teamwork (A).
- Develop skills for effective teamwork (S).
- Believe that maintenance personnel, flight crew, cabin crew, operations personnel, planners, etc., should work together as effectively as possible (A).
- Encourage a team concept, but without devolving or degrading individual responsibility (A).
- Understand the role of managers, supervisors and leaders in teamwork (K).
- Develop team management skills for appropriate personnel (S).
- Develop decision-making skills based on good situational awareness and consultation where appropriate (S).

9. Professionalism and integrity:

- Understand what is expected from individuals in terms of professionalism, integrity and personal responsibility (K).
- Understand the person's responsibility to keep standards high and to put this into practice at all times (A).
- Accept the personal responsibility to keep up to date with necessary knowledge and information (A).
- Achieve a good understanding of what is error-provoking behaviour (K).
- Appreciate the importance of avoiding the type of behaviour which is likely to provoke errors (A).
- Appreciate the importance of being assertive (A).

10. The maintenance organization's own Human Factors programme:

- Achieve an in-depth understanding of the structure and aims of the company's own Human Factors programme, for example:
  - The Maintenance Error System (K).
  - Links to the Quality and Safety Management Systems (K).
  - Disciplinary reporting and a just culture (K).
  - Top-level management support (K).
  - Human Factors training for all maintenance organization staff (K).
  - Actions to address problems (K).
  - Good safety culture (K).
- Appreciate the importance of reporting incidents, errors and problems (A).
- Understand what types of problems should be reported (K).
- Understand the mechanisms of reporting (K).
- Understand the organization's policy and the circumstances under which disciplinary action may be appropriate and when not appropriate (K).
- Appreciate that the person will not be unfairly penalized for reporting or assisting with disciplinary investigations (A).
- Understand the mechanisms of incident investigation (K).
- Understand the mechanisms of actions to address errors (K).
- Understand the mechanisms of feedback (K).



## Appendix 1 to Chapter 1

# PILOT TRAINING IN HUMAN FACTORS CONSIDERATIONS IN CURRICULUM DEVELOPMENT

### TARGET AUDIENCE

1. Possible pilot categories: ab initio, general aviation, commercial, air carrier and instructor pilots.
2. Identify non-pilot/supervisor specialist training needs according to occupational function.

### TRAINING DIRECTION AND OBJECTIVES

1. Identify the role of theoretical and experiential learning. Determine the role of Open Learning, development of reflective practice, and activities promoting experiential learning.
2. Review the approach to briefing, debriefing and assessment practices.
3. Curriculum/course content categorization under "Memorizing", "Understanding", "Doing" and "Attitudinal aspects".
4. Suggested curriculum categorizations or "domains" of trainee competence:
  - a) Knowledge-based ("memorizing"): didactic or factual knowledge and appropriate procedural or contextual information.
  - b) Comprehension-based ("understanding"): understanding of relevant theory, etc.
  - c) Skill/technique-based ("doing"): acquire and demonstrate required practical skills.
  - d) Attitudes ("attitudinal aspects"): application and understanding of appropriate professional practices and dispositions.
5. Determine the different types of post-training competency, or subject mastery, expected of trainees.

### TRAINING MATERIALS, TECHNIQUES AND EDUCATIONAL TECHNOLOGIES

Division by training hardware, training strategies/techniques, training courseware and assessment/evaluatory practices.

- a) Training hardware: identify training hardware relevant to training needs and objectives.
- b) Training strategies and techniques:
  - 1) identify training strategies/techniques made possible by the available training technology;
  - 2) determine the need for performance feedback; identify the quality of feedback required and the means of achieving this;
  - 3) determine if psychological testing/evaluation should play a part;
  - 4) identify the means by which individual as well as crew training needs can be successfully addressed;
  - 5) assess the role of multi-method training;
  - 6) determine the potential value of role play, case-studies, simulation gaming, written simulations, etc.;
  - 7) select those methods to best achieve the contrasting training needs outlined in the section above;
  - 8) identify training needs of specialist course instructors.
- c) Training courseware:
  - 1) identify resource constraints and training objectives;

- 2) courseware development as part as a dedicated Human Factors course, as part of recurrent training or for integration into current training practice;
- 3) identify associated training needs of relevant instructors.

#### **PILOT ASSESSMENT AND TRAINING COURSE EVALUATION**

1. Determine if there is a desire for concurrent course evaluation and/or formal pilot assessment. Review available alternatives.

2. Identify appropriate means of assessment for "knowledge", "comprehension", "skill/ technique" and "attitudinal" categories.

3. Address the tension between learning and assessment practices/consequences for skill/ technique and experiential learning.

4. Determine the role of crew-based vs. individual performance appraisal.

5. Identify the training needs of those involved in evaluation and/or performance assessment.

## Appendix 2 to Chapter 1

### SAMPLE QUESTIONNAIRE TO TEST ANNEX 1 HUMAN FACTORS KNOWLEDGE REQUIREMENTS

1. Name four important disciplines from which information is drawn in understanding human performance and behaviour.
2. What four major interfaces must be optimized on the flight deck to provide the basis of safe and efficient flight operations?
3. About what proportion of civil air accidents result from inadequate human performance?
4. a) What is meant by the authority gradient between pilots?  
b) Why is this important for flight safety?  
c) Name three different potentially unsafe gradients.
5. a) Give two important safety advantages in the development of standard, habitual behaviour in flight deck tasks.  
b) What is meant by behaviour reversion? Give an example of this related to flight deck activities which can prejudice flight safety.
6. a) What general aspect of human performance is illustrated by the Yerkes-Dodson curve?  
b) How can the incidence of human error be related to this curve?  
c) Where would you place complacency, boredom and excitement on the curve?  
d) What does this curve suggest about performance of critical tasks?
7. a) What pattern of performance can be expected in tasks requiring continuous vigilance?  
b) Name one flight deck task which could illustrate this.
8. The false hypothesis is a dangerous form of human error. Name five different situations in which this is most likely to occur.
9. Give three examples of zeitgebers or entraining agents related to circadian rhythms.
10. Human performance varies with a circadian rhythm.
  - a) What does this mean?
  - b) Related to this phenomenon, what is meant by the terms:
    - task-dependent,
    - post-lunch dip,
    - motivation effect, and
    - acrophase?
  - c) Give four factors, excluding zeitgebers, which may be associated with the rate of resynchronization of biological rhythms after they have been disturbed on a long flight.
11. a) What is the name given to the group of drugs (hypnotics) most commonly used to facilitate sleep?  
b) In this connection, what is meant by half-life and how does this relate to the drug's effect on performance?  
c) State the general precautions (approximately six) that a pilot is recommended to take before deciding to use a hypnotic (sleeping drug).
12. a) What is meant by the sleep inertia effect?  
b) What relevance does this have for flight safety on the flight deck?  
c) Is performance likely to deteriorate steadily with increasing sleep loss? Explain.

13. a) Cigarette smoke contains carbon monoxide. What effect does this have on human altitude tolerance and how does this occur?
- b) What other effect on performance related to safety may carbon monoxide have?
14. a) Give four factors which affect the rate at which alcohol is absorbed by the body.
- b) At about what rate does the blood alcohol content (BAC) fall after stopping drinking and is this rather constant between individuals?
- c) From about what BAC have experiments demonstrated a measurable deterioration in brain and body functions?
15. a) What is meant by:
- the Mandelbaum effect,
  - empty field, and
  - dark focus?
- b) Why are these important for safety in visual collision avoidance?
16. a) What is meant by the blind spot?
- b) How can this influence safety in visual look-out from the flight deck?
- c) How are the risks from this source reduced?
17. a) What is meant by the design eye position?
- b) Why should the pilot assure that his eye is in this position and how can this affect safety?
- c) Can all pilots physically assume this point?
18. a) What visual illusions or reactions in aircraft are related to:
- the autokinetic effect,
  - the stroboscopic effect,
  - blowing snow,
  - acceleration,
  - fog,
  - sloping terrain,
  - sloping runway, and
  - the black hole?
- b) What are the general basic stages (give three) in providing protection against the effect of illusions?
19. With respect to vision:
- a) What is meant by accommodation, dark adaptation, visual acuity?
- b) How are these related to safety?
20. What principle related to human performance modification is known as the Hawthorne Effect?
21. a) What is meant by behaviour reinforcement?
- b) Give two examples each of positive and negative reinforcement.
- c) What precautions should be observed when the use of negative reinforcement is indicated (give four)?
22. a) What is meant by achievement motivation?
- b) Why is this relevant to the pilot's job and flight safety?
- c) Can this be readily developed?
23. Boredom is often associated with low performance.
- a) Give four basic conditions which tend to be associated with boredom.
- b) Is boredom necessarily created by a given task? Explain.
24. a) What personal characteristics (give five) are often associated with leadership?
- b) Are leaders born or made? Explain.
25. Explain the meaning of and difference between:
- a) leadership;
- b) authority; and
- c) domination.
26. Speech communication has been the source of many errors, incidents and accidents.

- a) What dangerous role can expectation play in verbal communication in aircraft?
- b) Give an example from radiotelephony communication.
- c) What means (give four) can be used to provide protection against this danger?
27. a) Explain, with particular relevance to safety aspects, the difference between personality, attitudes, beliefs and opinions.
- b) Suggest one way each that a personality and an attitude characteristic can adversely affect operational safety.
- c) To what extent is it possible to modify in airline service personality and attitudes of pilots by training?
28. Attitudes may be said to have three components.
- a) Name three components.
- b) Relate these to attitudes towards cockpit checklist use.
29. In what manner may individual judgement be influenced by membership of a group or team with regard to:
- a) risk-taking;
- b) inhibition;
- c) conformity.
30. Education and training are two aspects of the teaching process.
- a) Explain the difference and how they relate to each other.
- b) Which of these covers learning of flying skills, basic Human Factors knowledge, flight planning, aircraft systems, physics, aircraft emergency procedures?
- c) Give an example to illustrate the difference between knowledge and skill.
31. a) What is meant by negative training transfer?
- b) Give an example of this which can jeopardize flight safety.
- c) What is meant by fidelity in training devices and is this necessary for training effectiveness? Explain.
32. Memory can have an important impact on flight safety. In this connection:
- a) What is meant by overlearning?
- b) What is meant by chunking?
- c) What is the difference between the effectiveness of memory of continuous and serial activities?
33. a) What is meant by feedback in training?
- b) What is meant by open- and closed-loop systems?
- c) What is the difference between intrinsic and extrinsic feedback, and why is it important for flight training effectiveness that flight instructors and pilot students recognize this difference?
34. Colour coding is a useful means of distinguishing between different sections of a manual, which can be critical when information must be found quickly, as in emergencies. Name two basic limitations in connexion with reliance on the use of colour coding for this purpose.
35. Evaluation of flight deck and safety equipment is often done by questionnaires completed by pilots. The validity of the assessment of the equipment depends on the validity of the questions and responses. In this respect, what is meant by:
- a) prestige bias;
- b) open-ended and closed questions;
- c) order effect;
- d) middle option; and
- e) acquiescence, multiplicity and expectation in questions.
36. a) What are the three sensory channels used to obtain information from flight deck displays in large transport aircraft?

- b) Give two fundamental operational differences between auditory and visual displays?
37. a) Instrument reading difficulty/error can arise from two basic causes when most conventional, round-dial, electromechanical instruments are viewed from an angle. What are these?
- b) Give two operational reasons each why an analogue and a digital display may be preferred.
38. a) Name three basic functions of a flight deck alerting system.
- b) What is meant by a nuisance warning and how does it differ from a false warning? What behavioural consequences affecting safety can arise from them?
- c) How can an alerting system generate negative training transfer and what risk to flight safety may result?
39. a) What is meant by and what are the operating implications of control-display ratio and control resistance?
- b) Give four methods of control coding to reduce operating errors.
- c) Give five methods of protection against the adverse consequences of inadvertent switch operation.
- d) What is meant by the forward-on and sweep-on switch concept and what are the operational and safety consequences of relocating cockpit panels with each concept?
40. a) Name two possible behavioural consequences of automation of flight deck tasks which may adversely affect safety.
- b) Give three broad justifications for the automation of flight deck tasks.
41. a) In what cabin conditions can inconsistency in emergency equipment location within the fleet be particularly hazardous?
- b) Why should cabin crew be familiar with the operating controls of pilot seats?
42. a) What is meant by the sterile cockpit?
- b) Does this have any legal or mandatory backing? Explain.
- c) Name two cabin and two flight deck activities which would come within the scope of this restriction.
43. a) What basic limitation exists in the use of colour-coding and placarding to optimize emergency equipment use? How can this influence training?
- b) Name two important basic problems associated with passenger cabin safety briefing which can prejudice survival in emergency, and suggest two ways in which these problems can be reduced.
- c) Name 15 different aspects of cabin interior design which require Human Factors input to optimize safety and explain the relevance to survival in emergencies.
-

## Appendix 3 to Chapter 1

### APPLIED HUMAN FACTORS IN ATC — a fictitious case study

*Human Factors: a phrase that is now known to most people in ATC. But is everyone familiar with the theory models associated with it? And, more importantly, are people aware that Human Factors is more than just a theory, and that we encounter it in our working environments daily?*

*The purpose of this appendix is to illustrate, by means of an example, what Human Factors in ATC is all about. The case study consists of three parts. Part One describes the circumstances under which an accident occurred, Part Two gives more information on the background of the persons involved (Human Factors issues), whereas Part Three indicates what possible improvements can be (or could have been) made to prevent such an accident from happening (again).*

#### PART ONE THE CIRCUMSTANCES

In the early hours of an autumn Monday morning, a twin-engined jet transport with five crew members and 63 passengers on board, while in its take-off run at Anyfield Airport, collided with a small twin-engined propeller-driven aircraft, with only a single crew member, that had intruded the departure runway. The subsequent fire destroyed both aircraft and was the cause of death for most of the passengers.

Anyfield Airport is a medium-sized airport, with a single runway which can be accessed (or vacated) by a number of intersections. It is a controlled aerodrome, the control tower is located 400 m north of the middle of the runway. Traffic numbers are on the rise as quite a few commuter-type airlines have started operating to and from Anyfield.

Although the airport is in a region in which several foggy days a year are common, it is not equipped with a Surface Movement Radar (SMR), nor does it have special taxiway lighting facilities for use under low visibility conditions.

Air Traffic Control at Anyfield is slightly understaffed, but so far it was not thought necessary to impose restrictions on operations to and from Anyfield. There is a discrete frequency to handle taxiing aircraft ("Ground control").

At the time of the collision, the average visibility was around 700 m with fog-banks, which is just sufficient to allow the tower controller to see the middle part of the runway. The controllers' view at the intersection where the intruding aircraft entered the runway, however, was obstructed by the newly constructed extension to the terminal building at Anyfield Airport.

The ATCO was a very experienced controller. He had been working in ATC for many years, at several major facilities, and had been transferred to Anyfield to act as an OJT instructor only eight months before the date of the accident.

The ATCO was alone in the control tower, as his assistant/ground controller (of far less experience) had briefly left the TWR to answer a call of nature. They were both completing their third consecutive nightshift, had come on duty at 2200 hours the previous evening and were due to be relieved within 30 minutes when the accident occurred.

The crew of the jet-aircraft were experienced operators to and from Anyfield. From their point of view, there was nothing unusual in the way their flight was handled by ATC. They taxied to the runway with the extra caution required by the foggy conditions, and after being cleared for take-off they made certain they were lined up correctly on the runway centreline before applying take-off power.

The pilot of the twin-engined piston-driven aircraft was unfamiliar with Anyfield Airport, having been sent there at short notice to collect an aircraft that had to divert to Anyfield two days earlier for weather reasons.

#### PART TWO BACKGROUND DETAILS — THE HUMAN FACTORS

Although the ATCO was very experienced, he had only worked a limited number of solo shifts in Anyfield Tower

(TWR). Having validated his TWR rating in early summer, he had been involved in giving OJT instructions on most of his shifts after that. As a consequence of the staff shortage, he was required to work his share of nightshifts like all other controllers. The shift in which the accident occurred was only his **second** at Anyfield TWR where he had worked under foggy/low visibility conditions; the first had been the previous night, when there was hardly any traffic as it was the Saturday to Sunday shift.

A number of years ago there had been an incident at Anyfield involving runway intrusion by a vehicle under similar meteorological conditions as in this case. One of the recommendations at that time was the installation of an SMR, together with stop-bars at all runway intersections. The authorities decided that in view of the limited number of days (with fog) that would warrant the use of an SMR, the benefit of having an SMR did not match the costs of having one installed. The same applied for the installation of stop-bars, but in lieu of those, painted signs had been put in the grass next to the runway intersections informing those who noticed them there was a "runway ahead".

As the early morning traffic began to come alive, the ATCO and his G/C were each working an independent R/T frequency. When the G/C announced he had to visit the men's room for a second, the ATCO told him to go ahead, intending to work both frequencies by himself. In order to do so, the ATCO had to physically move between two control positions in the TWR that are about 3 m apart, for Anyfield TWR is not equipped with a frequency-coupling installation. Transmissions on one frequency cannot be heard by stations on the other frequency.

The piston-engined aircraft's pilot had arrived in Anyfield late the night before. After a short sleep he went to the airport quickly in order to waste as little time as possible, for his company wanted the aircraft back at its homebase as soon as possible. After the minimum of preparation needed, he went to his aircraft and called ATC for approval to taxi to the runway. He obtained the clearance and began taxiing, but soon found himself lost at the foggy, unfamiliar airport. The fact that there were no signs denominating the various taxiway intersections did not help much either.

The R/T tapes showed that the piston-engined aircraft's pilot then called G/C (by R/T) and asked for "progressive taxi instructions". G/C replied by asking his position. The pilot said: "I believe I'm approaching Foxtrot intersection", to which G/C answered: "At Foxtrot taxi straight ahead". In fact, the pilot had already passed Foxtrot, and should have turned onto the parallel taxiway. The instruction from G/C, though technically correct, caused the pilot to taxi onto the

runway where the jet was in its take-off roll. Since the communications to both aircraft took place on different frequencies, neither pilot was aware of what was happening.

After the collision, it took the ATCO several minutes to realize something was wrong. Of course, he had not observed the departing jet passing on the section of the runway that was visible to him, but he initially blamed that on the fog patches and/or being distracted by traffic on the G/C frequency.

Apart from the fog, the ATCO was unable to see the part of the runway where the collision had taken place because of the newly-built extension of the terminal building blocking his view. So it was not until he wanted to transfer the departing jet to the next controller (Departure Control) that he became aware things were not as they should be, as his transmissions to the jet remained unanswered.

His G/C, who returned shortly after the accident, at the same time reported having no contact with the taxiing twin-prop. The ATCO then decided to alert the fire brigade, but as he had no idea where to send them, more precious time was lost as the rescue vehicles tried to make their way across the foggy airport. When they finally arrived at the accident-site, they found there was little they could do as the wreckage of the aircraft had almost completely burned out.

### PART THREE PREVENTIVE MEASURES

Had an SMR been installed following the recommendation after the other incident, this would have provided the following lines of defence (in declining order):

- proper taxi-instructions could have been given to the "lost" aircraft;
- the ATCOs would have observed the runway intrusion;
- the collision site would have been easily identified;
- adequate instructions could have been given to the rescue vehicles.

This goes for the stop-bars as well. Had they been installed, the twin-prop more likely than not, would not have entered the runway.



At the very least, special procedures for Low Visibility Operations at Anyfield should have been developed and in force, limiting the number of movements at the field. The ATCOs should have been trained in working with these special procedures, ideally on a simulator, to help them cope with the unusual situation once it occurred.

In their talks with the airport authorities, ATC management should have firmly opposed the plans for extension of the terminal building. But, as a result of not having any input from the operational ATCOs (who were not available to attend the meetings due to staff shortages), management was not even aware it would constitute a line-of-vision problem from the TWR.

The ATCO should not find himself in a position where he was forced to work two positions by himself. At all times ATC positions should be sufficiently staffed to allow the traffic to be handled in a safe manner.

The installation of a frequency-coupler might have helped prevent the collision from occurring. As it is, these systems are considered "optional" by the aviation authorities, so only few ATC facilities have them.

Management should ensure that OJT instructors are given the opportunity to stay current at the positions where they are supposed to teach, by scheduling the instructor for duties without trainees at regular intervals. Such duties should be sufficiently challenging to allow the instructor to practise her skills (in other words: shifts without traffic may look good in a roster, but are of no value for currency-maintaining purposes!)

Had there been a well-devised training curriculum that was correlated with the duty roster, management would have recognized that the ATCO, although qualified, had not been able to acquaint himself with working at Anyfield TWR under low visibility conditions. Ideally, they would not have scheduled him for unsupervised duty when low visibility was forecast.

Dedicated low-visibility operations-training would have made the ATCO aware of the dangers involved, alerting

him to be more positive in guiding the lost taxiing pilot. At the very least he probably would not have given the pilot irrelevant information.

It is a scientific fact that when consecutive night shifts are worked, the performance of persons engaged in cognitive tasks (such as ATC) decreases dramatically in the second and later nights, especially between 0300 hours and 0700 hours. The ATCO at Anyfield was on his third night shift in a row, which could explain why he failed to recognize a potentially dangerous situation that he would not have missed under other circumstances. When designing shift rosters for ATCOs, it is advisable to keep the number of consecutive night shifts to an absolute minimum.

Based on the weather forecast, and taking into account the propeller-aircraft's pilot was unfamiliar with Anyfield, it may be argued that the operator would have done better to send **two** pilots to collect the aircraft. Even with limited knowledge of CRM principles, a second pilot could have prevented the other pilot from acting the way he did.

## EPILOGUE

In Part Three there is an extensive list of Latent Failures that all contributed towards the opportunity for the accident to happen. But are there also Active Failures in the story? According to the theory they have to be there, or else there would not have been an accident.

And indeed there are two Active Failures: one by the piston-engined aircraft's pilot, and one by the ATCO. The pilot failed to notice entering the runway, the ATCO failed to adequately respond to the pilot's indication that he was lost while taxiing.

It is important to note that the Active Failure by the pilot could not have occurred without the one by the ATCO first. In other words: just that one Active Failure was all that was required to cause the accident to happen, since the opportunity for it had been created well in advance by a series of Latent Failures.

## Chapter 2

# CREW RESOURCE MANAGEMENT (CRM) TRAINING

### 2.1 INTRODUCTION

2.1.1 This chapter is intended as an aid for civil aviation administrations and for operators who must now include human performance training in their operational personnel training curricula. This includes those engaged in Human Factors and CRM training design, administration and research and, specifically, training managers and/or Human Factors and CRM managers. Although it is mostly oriented towards flight crew training, the basic concepts presented are applicable to cabin crew and flight dispatcher training.

### 2.2 CREW RESOURCE MANAGEMENT (CRM) TRAINING

#### The human factors requirements in Annex 6

2.2.1 In 1994, the ICAO Air Navigation Commission reviewed Annex 6 (*Operation of Aircraft*) and adopted a proposal to include a Standard in Annex 6 regarding initial and recurrent human performance training for flight crews. This Standard, promulgated through Amendment 21 to Annex 6, became applicable in November 1995.

2.2.2 The text of the amendment included in Part I, Chapter 9 (Aeroplane flight crew), 9.3.1, indicates that:

“The training programme shall also include training in knowledge and skills related to human performance ...”.

It further requires that:

“The training programme shall be given on a recurrent basis, as determined by the State of the Operator ...”.

2.2.3 In 1995, the Air Navigation Commission further reviewed Annex 6 and adopted a proposal to include additional Standards and a Recommended Practice regarding human performance training for maintenance personnel, flight operations officers/flight dispatchers, and

cabin attendants. The various Standards and Recommended Practices, promulgated through Amendment 23 to Annex 6, became applicable in November 1998.

2.2.4 The text of the amendment included in Part I, Chapter 8 (Aeroplane maintenance), 8.7.5.4, indicates that:

“The training programme established by the maintenance organization shall include training in knowledge and skills related to human performance, including coordination with other maintenance personnel and flight crew.”

2.2.5 Furthermore, Part I, Chapter 10 (Flight operations officer/flight dispatcher), 10.2, indicates that:

“A flight operations officer/flight dispatcher should not be assigned to duty unless that officer has:

...

d) demonstrated to the operator knowledge and skills related to human performance relevant to dispatch duties ...”.

Paragraph 10.3 further indicates that:

“A flight operations officer/flight dispatcher assigned to duty should maintain complete familiarization with all features of the operation which are pertinent to such duties, including knowledge and skills related to human performance.”

2.2.6 Lastly, Part I, Chapter 12 (Cabin crew), indicates, under 12.4, that the cabin crew training programme:

“... shall ensure that each person is:

...

f) knowledgeable about human performance as related to passenger cabin safety duties including flight crew-cabin crew coordination.”

Paragraph 12.4 also indicates that cabin crews shall complete a recurrent training programme annually.

### **The implications of the Human Factors requirements in Annex 6**

2.2.7 Amendments 21 and 23 to Annex 6 carry important consequences for the international aviation community. The requirement to develop human performance knowledge and skills among flight crew members and other operational personnel has the same weight as that related to systems, and normal, abnormal and emergency procedures. Non-compliance with the requirement to provide human performance training would mean non-compliance with an international Standard. Most operators comply with the human performance training requirement, mainly through Crew Resource Management (CRM) Training and Line-Oriented Flight Training (LOFT).

### **The evolution of CRM**

2.2.8 From the onset, it is important to place CRM within the scope of Human Factors training: CRM is but *one* practical application of Human Factors training, concerned with supporting crew responses to threats and errors that manifest in the operating environment. The objective of CRM training is to contribute to incident and accident prevention.

2.2.9 CRM is a widely implemented strategy in the aviation community as a training countermeasure to human error. Traditionally, CRM has been defined as the utilization of all resources available to the crew to manage human error. Airlines have invested considerable resources to develop CRM programmes, in many varied ways and with a multiplicity of designs. What follows is a brief evolution of the development of CRM, to provide a perspective on how the concept has evolved since its inception and operational deployment.

2.2.10 The roots of CRM training are usually traced back to a workshop, *Resource Management on the Flight Deck*, sponsored by the National Aeronautics and Space Administration (NASA) in 1979. This workshop was the outgrowth of NASA research into the causes of air transport accidents. The research presented at this workshop identified the human error aspects of the majority of air crashes as failures of interpersonal communications, decision making and leadership. At this workshop, the label Cockpit Resource Management (CRM) was applied to the process of training crews to address "pilot error" by making

better use of the resources on the flight deck. Many of the air carriers represented at this workshop took home with them a commitment to develop new training programmes in order to enhance the interpersonal aspects of flight operations. Since that time, CRM training programmes have proliferated around the world. Approaches to CRM have also evolved in the years since the NASA workshop.

### **First generation cockpit resource management**

2.2.11 United Airlines initiated the first comprehensive CRM programme in 1981. The training was developed with the aid of consultants who had developed training interventions for corporations that were trying to enhance managerial effectiveness. It was conducted in an intensive seminar setting and included participants' diagnoses of their own managerial style. Other airline programmes in this era also drew heavily on management training principles. These programmes emphasized changing individual styles and correcting deficiencies in individual behaviour such as lack of assertiveness by juniors and authoritarian behaviour by captains. Supporting this emphasis, the National Transportation Safety Board had singled out the captain's failure to accept input from junior crew members (a characteristic sometimes referred to as the "Wrong Stuff") and lack of assertiveness by the flight engineer as causal factors in a United Airlines crash in 1978.

2.2.12 First generation CRM seminars used psychology as a foundation, with a heavy focus on psychological testing and general management concepts such as leadership. They advocated strategies of interpersonal behaviour without providing clear definitions of appropriate behaviour in the cockpit. Many employed games and exercises unrelated to aviation to illustrate concepts. It was also recognized that CRM training should not be a single experience in a pilot's career and that annual recurrent training in CRM should become part of the programme. In addition to classroom training, some programmes also included full mission simulator training (Line-Oriented Flight Training, or LOFT) where crews could practice interpersonal skills without jeopardy. However, despite overall acceptance, many of these courses encountered resistance from pilots, who denounced them as "charm school" or attempts to manipulate their personalities.

### **Second generation "crew" resource management**

2.2.13 NASA held another workshop for the industry in 1986. By this time a growing number of airlines around

the world had initiated CRM training, and many reported the successes and pitfalls of their programmes. One of the conclusions drawn by working groups at the workshop was that explicit (or stand alone) CRM training would ultimately disappear as a separate component of training and that it would become embedded in the fabric of flight training and flight operations.

2.2.14 At the same time, a new generation of CRM courses was beginning to emerge. Accompanying a change in the emphasis of training to focus on cockpit group dynamics was a change in name from "Cockpit" to "Crew" Resource Management. The new courses dealt with more specific aviation concepts related to flight operations and became more modular as well as more team-oriented in nature. Basic training conducted in intensive seminars included concepts such as team-building, briefing strategies, situational awareness and stress management. Specific modules addressed decision-making strategies and breaking the chain of errors that can result in catastrophe. Many of the courses still relied on exercises unrelated to aviation to demonstrate concepts. Participant acceptance of these courses was generally greater than that of the first generation, but criticisms persisted that the training was heavily laced with psychology-based contents. Second generation courses still continue to be used in many parts of the world.

### Third generation crew resource management

2.2.15 In the early 1990s, CRM training began to proceed down multiple paths. Training began to reflect characteristics of the aviation system in which crews must function, including the multiple input factors — such as organizational culture — that determine safety. At the same time, efforts were made to integrate CRM with technical training and to focus on specific skills and behaviours that pilots could use to function more effectively. Several airlines began to include modules addressing CRM issues in the use of flight deck automation. Programmes also began to address the recognition and assessment<sup>1</sup> of Human Factors issues. Accompanying this was the initiation of advanced CRM training for check airmen and others responsible for training, reinforcement and evaluation of both technical and Human Factors competencies.

1. Assessment means understanding how well specific behaviours are enacted, *not* formal evaluation of Human Factors skills.

2.2.16 With the greater specificity in training for flight crews, CRM began to be extended to other groups within airlines, such as flight attendants, dispatchers and maintenance personnel. Many airlines began to conduct joint cockpit-cabin CRM training. A number of carriers also developed specialized CRM training for new captains to focus on the leadership role that accompanies command.

2.2.17 While third generation courses filled a recognized need to extend the concept of the flight crew, they may, by broadening the scope of CRM training, also have had the unintended consequence of diluting the original focus — the management of human error.

### Fourth generation crew resource management

2.2.18 In 1990, the Federal Aviation Administration introduced a major change in the training and qualification of flight crews with the initiation of its Advanced Qualification Programme (AQP), a voluntary programme that allows air carriers to develop innovative training that fits the needs of a specific organization. In exchange for this greater flexibility in training, carriers are required to provide both CRM and LOFT for all flight crews and to integrate CRM concepts into technical training. To complete the shift to AQP, carriers are required to complete detailed analyses of training requirements for each aircraft and to develop programmes that address the CRM issues in each aspect of training. In addition, special training for those charged with certification of crews and formal evaluation of crews in full mission simulation is required (Line Operational Evaluation, or LOE).

2.2.19 As part of the integration of CRM, several airlines have begun to "proceduralize" the concepts involved by adding specific behaviours to their normal and abnormal checklists. The goal is to ensure that decisions and actions are informed, by consideration of "bottom lines", and that the basics of CRM are observed, particularly in non-standard situations.

2.2.20 On the surface, the fourth generation of CRM would seem to solve the problems associated with human error by making CRM an integral part of all flight training. It would also appear that the goal of making explicit CRM training "go away" is starting to be realized. Although empirical data are not yet available, there is general consensus among U.S. airlines that the AQP approach yields improvements in the training and qualification of flight crews. However, the situation is more complex and the resolution not so straightforward. Before considering the

latest iteration of CRM, it may be valuable at this point to pause and examine what has been accomplished in the past two decades of CRM training.

### Successes and failures of CRM training

#### Validation of CRM

2.2.21 The fundamental question of whether CRM training can fulfil its purpose of increasing the safety and efficiency of flight operations does not have a simple answer. The most obvious validation criterion, the accident rate per million flights, cannot be used because the overall accident rate is so low and training programmes so variable that it will never be possible to draw data-based conclusions about the impact of training during a finite period of time. In the absence of a single and sovereign criterion measure, investigators are forced to use surrogate criteria to draw inferences more indirectly. Reports of incidents that do not result in accidents are another candidate criterion measure. However, incident reporting is voluntary, and one cannot know the true base rate of occurrences, which is necessary for validation.

2.2.22 The two most accessible criteria are behaviour on the flight deck and attitudes showing acceptance or rejection of CRM concepts. Formal evaluation during a full mission simulation (LOE) is a start. However, the fact that crews can demonstrate effective crew coordination while being assessed under jeopardy conditions does not mean that they practise these concepts during normal line operations. The most useful data can be obtained from line audits where crews are observed under non-jeopardy conditions. Data from such audits, called Line Operations Safety Audits (LOSA)<sup>2</sup>, has demonstrated that CRM training that includes LOFT and recurrent training does produce the desired behaviours. This finding is congruent with participant evaluations of training. Crews completing course evaluations report that it is effective and important training.

2.2.23 Attitudes are another indicator of effect because they reflect the cognitive aspects of the concepts espoused in training. While attitudes are not perfect predictors of behaviour, it is a truism that those whose attitudes show rejection of CRM are unlikely to follow its precepts behaviourally. The attitudes that have been measured to assess the impact of CRM were ones identified as playing a role in air accidents and incidents.

2. See Doc 9803, *Line Operations Safety Audit*.

#### Failure to follow CRM precepts in line operations

2.2.24 From the earliest courses to the present, some pilots have rejected the concepts of CRM. Such rejection is found in every airline, and efforts at remedial training for these pilots have, for the time being, not proved particularly effective.

2.2.25 While the majority of pilots endorse CRM, not all of its precepts have moved from the classroom to the line. For example, a number of airlines have introduced CRM modules to address the use of cockpit automation. This training advocates verification and acknowledgement of programming changes and switching to manual flight rather than reprogramming flight management computers in high workload situations or congested airspace. However, a significant percentage of pilots observed in line operations fail to follow these precepts.

#### Acceptance of basic CRM concepts may decay over time

2.2.26 A disturbing finding from research is a slippage in the acceptance of basic CRM concepts, even with recurrent training. The reasons for this are not immediately apparent, but it is possible to speculate about likely causes. One candidate is lack of management support for CRM and failure by evaluators such as line check airmen to reinforce its practice. Another is that as training has evolved from one generation to the next, the original, implicit goal of error management may have become lost. Proceduralizing CRM (that is, formally mandating CRM precepts) might also obscure the purpose of the behaviour. Support for this view comes from informal interviews with crews who are asked "What is CRM?" A typical response is "Training to make us work together better." While this is certainly true, it only represents part of the story. It seems that in the process of teaching people *how* to work together, the industry may have lost sight of *why* working together well is important. The overarching rationale for CRM — supporting crew responses to threats and errors that manifest in the operating environment — has apparently been lost.

#### CRM training did not export well

2.2.27 As first and second generation CRM training programmes began to proliferate, many airlines around the world began to purchase courses from other airlines or training organizations. Even within a country, courses imported from other organizations had less impact than those that were developed to reflect the organizational culture and operational issues of the receiving airline. The

situation was much worse when training courses from one country were delivered in another country. In many cases, the concepts presented were incongruent with the national culture of the pilots.

2.2.28 The Dutch scientist, Geert Hofstede, has defined dimensions of national culture, several of which are relevant to the acceptance of CRM training. High power distance (PD) cultures, such as Oriental and Latin American cultures, stress the absolute authority of leaders. Subordinates in these cultures are reluctant to question the decisions and actions of their superiors because they do not want to show disrespect. Exhortations to junior crew members to be more assertive in questioning their captains may fall on deaf ears in these cultures. Many cultures that are high in PD are also collectivist. In collectivist cultures, where emphasis is on interdependence and priority for group goals, the concept of teamwork and training that stresses the need for effective group behaviour may be readily accepted.

2.2.29 In contrast, highly individualistic cultures such as the North American culture stress both independence from the group and priority for personal goals. Individualists may cling to the stereotype of the lone pilot braving the elements and be less attuned to the group aspects of flight deck management. A third dimension, uncertainty avoidance (UA), refers to the need for rule-governed behaviour and clearly defined procedures. High UA cultures, such as Latin American countries, may be much more accepting of CRM concepts that are defined in terms of required behaviours. Anglo-Saxons are low in UA, which is reflected operationally in greater behavioural flexibility, but also weaker adherence to standard operating procedures (SOPs).

2.2.30 Management of cockpit automation is also influenced by national culture. Pilots from high PD and/or UA cultures show more unquestioning usage of automation while those from cultures low in PD and/or UA show a greater willingness to disengage. The low UA of North American pilots may account, in part, for frequent failure to complete checklists and the imperfect acceptance of proceduralized CRM in this context.

2.2.31 There is a growing trend for international carriers to include national culture as part of CRM training and to customize their programmes to achieve harmony with their own culture. This is an important development that should enhance the impact of CRM in those organizations.

2.2.32 Considering both the observed limitations of CRM and the differing reactions to CRM training by other

cultures, let us now turn to the fifth generation of CRM training that addresses the shortcomings of earlier training approaches.

### **Fifth generation crew resource management**

2.2.33 Returning to the original concept of CRM, it is concluded that the overarching justification for CRM should be *error management*. While human error management was the original impetus for even the first generation of CRM, the realization and articulation of this was imperfect. Even when the training advocated specific behaviours, the reason for utilizing them was not always explicit. What should be advocated is a more sharply defined justification that is accompanied by proactive organizational support.

### **CRM as error management**

2.2.34 Underlying the fifth generation of CRM is the premise that human error is ubiquitous, inevitable and a valuable source of information. If error is inevitable, CRM can be seen as a set of error countermeasures with three lines of defence. The first is the avoidance of error. The second is trapping incipient errors after they are committed. The third is mitigating the consequences of those errors which occur and are not trapped. This is graphically presented in Figure 2-1. The same set of CRM error countermeasures apply to each situation, the difference being in the time of detection. For example, consider an advanced technology aircraft that experiences a controlled flight into terrain (CFIT) because an improper waypoint is entered into the flight management computer (FMC). A careful briefing on approach procedures and possible pitfalls, combined with communication and verification of FMC entries, would probably avoid the error. Cross-checking entries before execution and monitoring of position should trap erroneous entries. Finally, as the last defence, inquiry and monitoring of the position should result in mitigating the consequences of an erroneously executed command before the CFIT.

2.2.35 To gain acceptance of the error management approach, organizations must communicate their formal understanding that errors will occur, and they should adopt a non-punitive approach to errors. (This does not imply that any organization should accept wilful violations of its rules or procedures.) In addition to "accepting" errors, organizations need to take steps to identify the nature and sources of errors in their operations. The Line Operations Safety Audit (LOSA) is the tool currently employed by airlines to this effect. For a full description of LOSA, refer to the *Line Operations Safety Audit (LOSA) Manual (Doc 9803)*.

### Considerations for fifth generation CRM

2.2.36 Fifth generation CRM aims to present errors as normal occurrences and to develop strategies for managing errors. Its basis should be formal instruction in the limitations of human performance. This includes communicating the nature of errors as well as empirical findings demonstrating the deleterious effects of stressors such as fatigue, work overload and emergencies. These topics, of course, require formal instruction, indicating that CRM should continue to have its own place in initial and recurrent training. These can be dramatically illustrated with

examples from accidents and incidents where human error played a causal role. Indeed, analysis of human performance is common to all generations of CRM training. It is argued, however, that even more powerful learning may result from the use of positive examples of how errors are detected and managed.

2.2.37 Pilots from all regions of the world have been found to hold unrealistic attitudes about the effects of stressors on their performance. The majority feel, for example, that truly professional pilots can leave personal problems behind while flying and that their decision-making

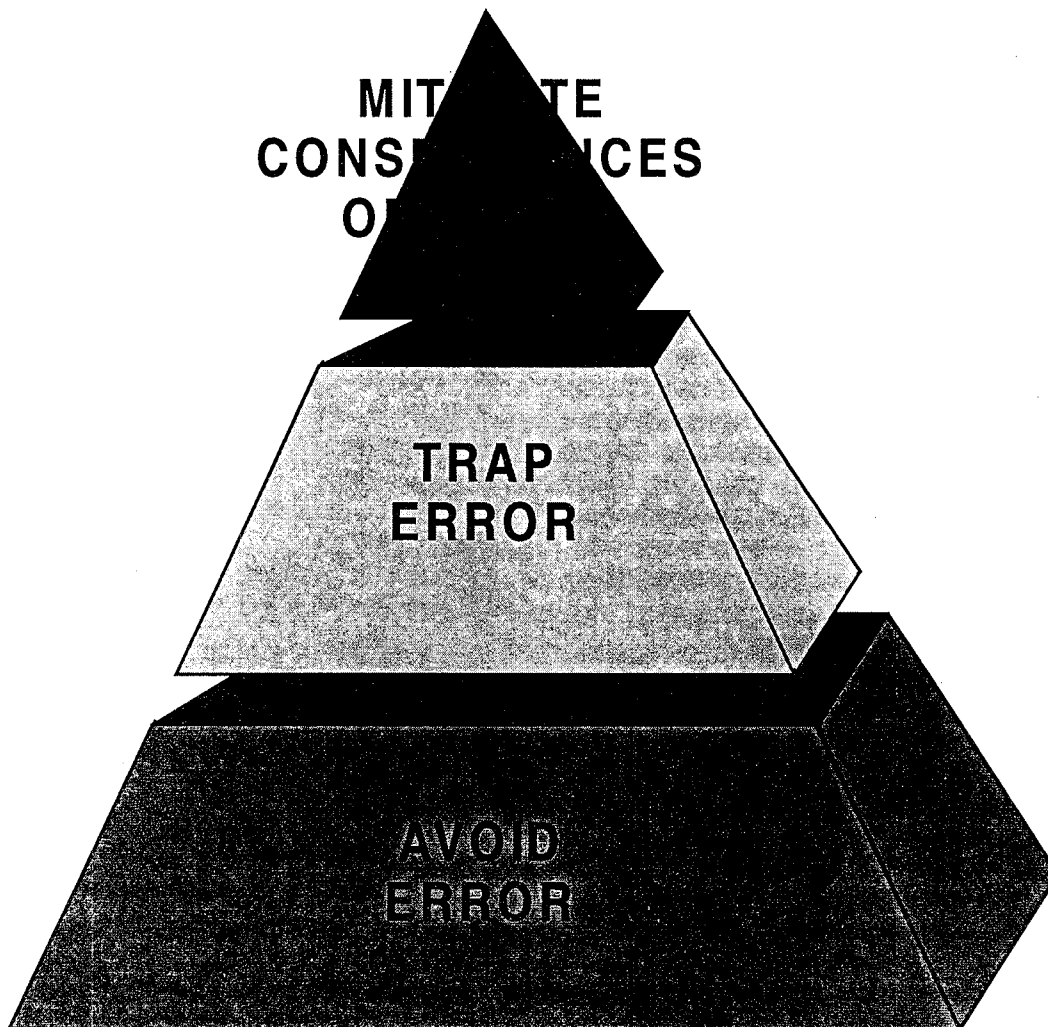

Figure 2-1. Primary goals of CRM

ability is the same in emergencies and normal operations. Training that demonstrates that these are erroneous or over-confident beliefs and that every individual is subject to stress can foster more realistic attitudes by reducing the onus attached to personal vulnerability. In turn, pilots who recognize the performance degradation associated with stress should more readily embrace CRM training as an essential countermeasure.

2.2.38 At the same time that error management becomes the primary focus of CRM training, training should be introduced for instructors and evaluators in the recognition and reinforcement of error management. This training should stress the fact that effective error management is the hallmark of effective crew performance and that well-managed errors are indicators of effective performance.

#### How does error management CRM relate to earlier generations?

2.2.39 Fifth generation CRM evolved from earlier generations. For example, special training in the use of automation, and the leadership role of captains, as highlighted in the third generation, can be neatly subsumed under this model. The error management approach should strengthen training by providing an all-important demonstration of the reasons for stressing CRM in all aspects of flight training. In the same vein, the integration of CRM into technical training, and the proceduralization of CRM, also fit under this umbrella and are likely to be better understood and accepted when the goals are clearly defined and organizationally endorsed. Pilots should also be better able to develop effective strategies for error management in situations where procedures are lacking and to provide a focal point for CRM skills that are not amenable to proceduralization.

2.2.40 Training modules such as the nature and importance of briefings can be seen as basic error management techniques. Similarly, joint training of cabin and cockpit crews can be seen as extending the scope of error management as one of the bases of a safety culture. Finally, clarification of the basic goals of CRM training may be the best way to reach the sceptics who should find it difficult to deny the importance of error management.

#### CRM in context

2.2.41 CRM is not and never will be the mechanism to eliminate error and ensure safety in a high-risk endeavour such as aviation. Error is an inevitable result of the natural

limitations of human performance and the function of complex systems. CRM is one of an array of tools that organizations can use to manage human error.

2.2.42 The safety of operations is influenced by professional, organizational and national cultures, and safety requires focusing each of these toward an organizational *safety culture* that deals with errors non-punitively and proactively. When CRM is viewed in the context of the aviation system, its contributions and limitations can be understood. What we do know is that the rationale for CRM training is as strong now as it was when the term was first coined.

#### Summarizing CRM success qualities

2.2.43 Summarizing these evolving generations, there are three foundations upon which to build strategic action to ensure continued CRM relevance and success:

- Operational error permeates the entirety of sociotechnical (i.e. human/technology) operational enterprises;
- A non-punitive response to operational error sets the best foundation to identify endemic conditions that breed errors within an organization; and
- Airlines that tolerate operational error and implement non-punitive policies are likely to better equip flight crews with appropriate countermeasures to deal with operational errors.

2.2.44 Focusing on the success qualities of CRM programmes, airlines have observed that effective and relevant CRM programmes are determined by certain success qualities:

- a) **Operational relevance.** Deliberate avoidance of classroom games, non-operational activities, and personality assessment.
- b) **Use of own experience.** Utilization of own incidents and accidents that reflect the typical safety issues of the airline. The airline is determined to learn from its own errors.
- c) **Crews are allowed to assess threats and their management.** Open discussion of threats within the airline and how these are detected, addressed and mitigated.



- d) **Examination of effective and ineffective error management.** Both effective and ineffective error countermeasures are highlighted, thus maximizing learning.

2.2.45 The fundamental purpose of CRM training is to improve flight safety through the effective use of error management strategies in individual as well as systemic areas of influence. Hence, it is only reasonable to refocus CRM as threat and error management (TEM) training. The objective therefore should be the integration of TEM into CRM.

## 2.3 THREAT AND ERROR MANAGEMENT (TEM) TRAINING

### Perspectives on accident/incident analysis

2.3.1 In the aftermath of accidents and incidents, inevitable questions arise: Why did the crew NOT see the obvious? If they had done what they were supposed to do, surely there would have been no accident in the first place? And the most daunting question is: "Why did a professionally trained team commit the error?"

2.3.2 A traditional perspective has been to analyse the incident from *outside* and *with hindsight*; for example, the crew was not able to meet the constraints of the operation because of poor or inappropriate flying skills. Hence, the most logical response to ensure that the crew is reinstated to standards is obviously retraining and supervision. Safety breakdowns are the product of people making errors. While such a response may fix defences that have been breached as a result of crew actions or inactions, tackling front-end operational errors on a one-by-one basis does not provide a lasting effect, since the number and nature of operational errors to tackle would be endless. Nonetheless, chasing the last error has been the traditional approach pursued by aviation in attempting to deal with operational errors. The limited success of this approach is a matter of record.

2.3.3 The other perspective is to view the event from *inside* and *in context*, accepting that operational threats and errors are inherent to, and manifest themselves within, operational environments. This means that mismanaged threats and errors made by the crew occur in inevitably imperfect systems, environments and procedures. Safety breakdowns are the product of good people trying to make sense of an operationally confusing context, rather than the product of bad people making errors.

### The TEM perspective

2.3.4 The TEM perspective proposes that threats and errors are pervasive in the operational environment within which flight crews operate. Threats are factors that originate outside the influence of the flight crew but must be managed by them. Threats are external to the flight deck. They increase the complexity of the operational environment and thus have the potential to foster flight crew errors. Bad weather, time pressures to meet departure/arrival slots, delays and, more recently, security events, are but a few of the real-life factors that impinge upon commercial flight operations. Flight crews must manage an ever-present "rain" of threats and errors, intrinsic to flight operations, to achieve the safety and efficiency goals of commercial air transportation. Sometimes these goals pose an apparent conflict. Nevertheless, safety and efficiency should not be presented as an *x/y* axis, but as a continuum line. While efficiency overarches the *raison d'être* of all commercial endeavours, safety goals reinforce the survival of commerce. The articulation of this concept to flight crews forms the bedrock of TEM training.

2.3.5 In attempting to understand human performance within an operational context, the focus of TEM is to identify, as closely as possible, the threats as they manifest themselves to the crew; to recreate crew response to the threats; and to analyse how the crew managed the consequent error in concordance with the native view. This is the perspective from the *inside* and *in context*. Such a view offers operational relevance to CRM.

2.3.6 The proposal then is to develop operational and practical strategies to train flight crews about threats and errors that are uniquely embedded in, and particular to, the operations of their airline. CRM is the training tool to achieve the objective of TEM (see Figure 2-2).

### The TEM model and the inevitability of operational errors

2.3.7 The concepts of communication, teamwork, decision making and leadership remain the hallmark of CRM training. For many years, they were proposed as routine "inoculation" of pilots against human error. Simply put, teaching pilots prescribed CRM behaviours, and enforcing their observance, would make human error go away. In retrospect, this approach ignored the fact that error is a normal component of human behaviour, and therefore inevitable in operational contexts. As long as humans remain involved in the aviation system, they will commit errors.

2.3.8 The goal of CRM should therefore be the recognition of threats to safe operations, as a first line of defence, since such *threats* are the breeding grounds for operational errors. The second line of defence is the use of appropriate threat management responses *to cancel threats*, and the recognition of the potential errors that threats might generate. The last line of defence is the use of appropriate *error management responses*. This principled approach, in four layers, to systemic threat and operational error management increases the likelihood of arriving at *outcomes* that minimize operational risks and ultimately preserve flight safety (see Figure 2-3).

2.3.9 The analogy of a filmstrip will illustrate the process. A single frame of film shows a still picture of a scene — a snapshot. A single frame does not portray movement. Without movement, there is no plot. Without a plot, there is no story. Ultimately, without a story, there is no motion picture, no message and no learning.

2.3.10 TEM operates in a manner analogous to a filmstrip. The constant movement and interplay of threats, responses by the crew, and outcomes that are desired in achieving a safe flight are the concern of TEM. Whereas the traditional view was to separate CRM from the technical

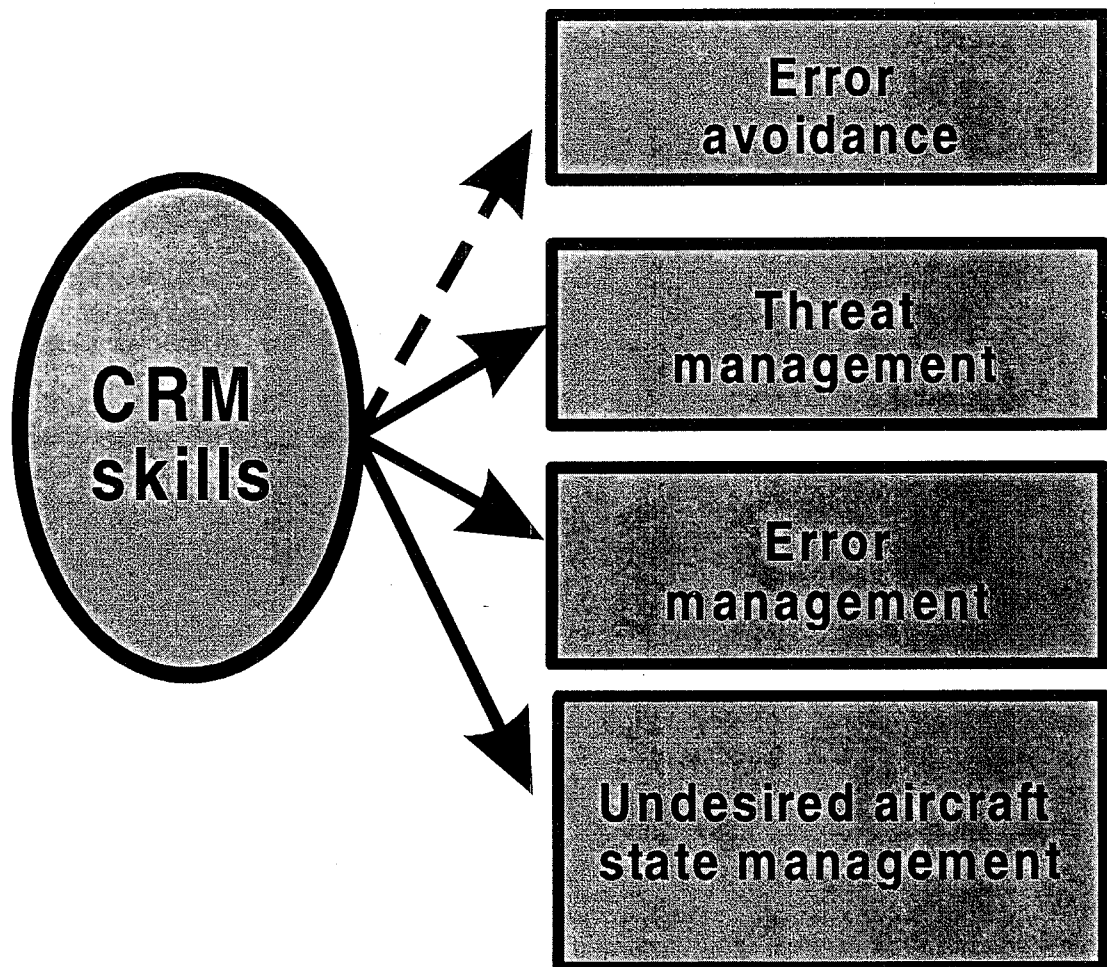

Figure 2-2. TEM — An operational training tool

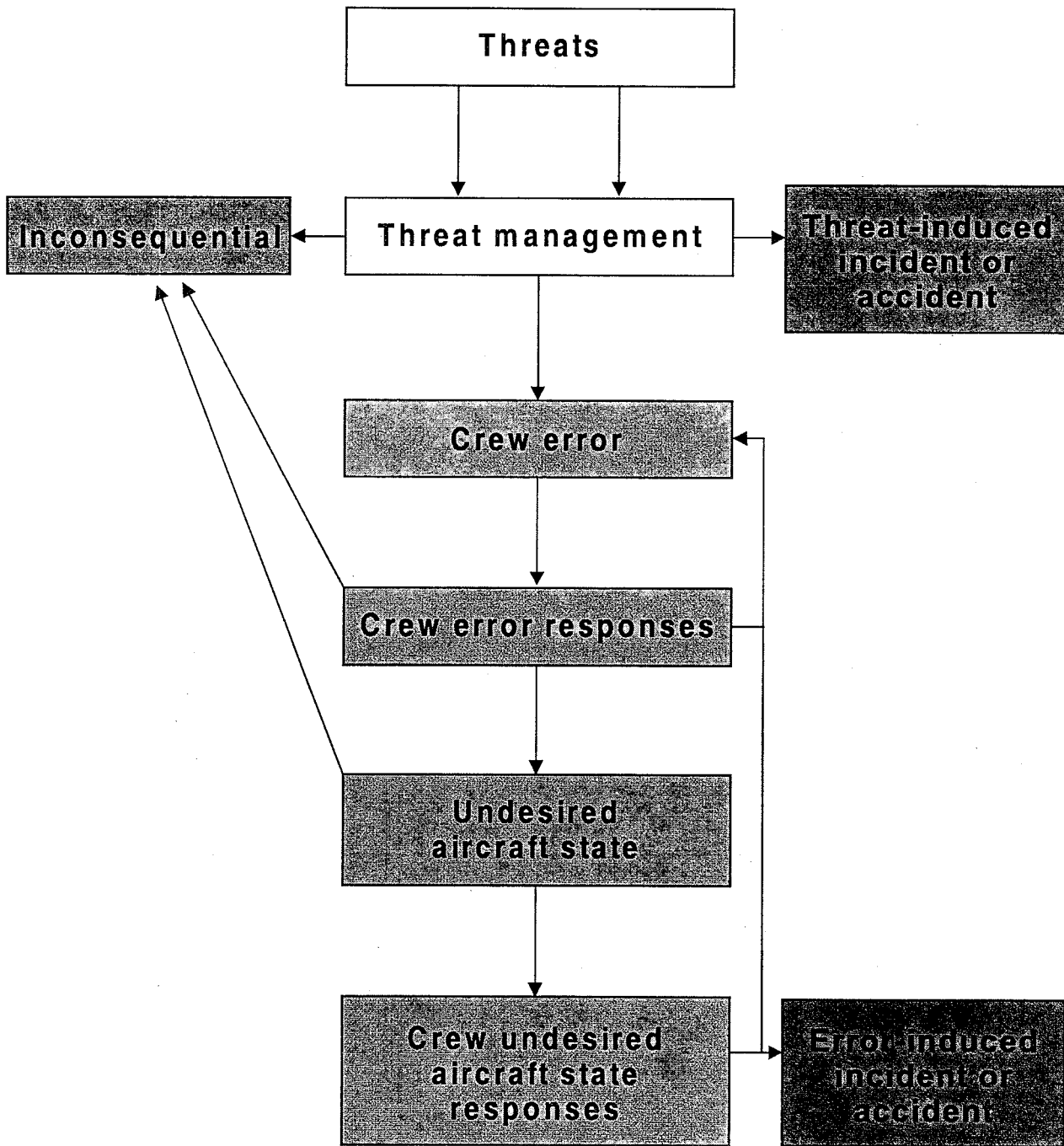

Figure 2-3. The threat and error management (TEM) model

aspects of flying an aircraft, threat and error management makes no such distinction. TEM encompasses the total process of error management in flight operations.

### Threat management

2.3.11 Threats impact on the crew's ability to manage a safe flight. An event or factor is qualified as a threat only if it is external to the flight deck, i.e. if it originates outside the influence of the crew (see Table 2-1). Crews must deal with threats while pursuing commercial objectives that underlie airline operations. Threats are not necessarily deficiencies in the aviation system, but external events that increase the complexity of flight operations and therefore

hold the potential to foster error. Threat management in flight operations is needed in order to sustain performance in demanding contexts. The total elimination of threats would only be possible by not flying at all. What is important is that crews recognize threats and can apply countermeasures to avoid, minimize or mitigate their effect on flight safety.

2.3.12 Threats can be either overt or latent. Overt threats are those that are tangible and observable to the crew. Examples of these include poor weather, aircraft malfunctions, automation events, ground events, aircraft traffic, terrain and airport/aerodrome facilities. Overt threats are a given in aviation, and very little can be done from the standpoint of the flight crew to control these threats.

**Table 2-1. Threats — external events, outside the influence of the crew, that require crew management**

<i>Type of threat</i>	<i>Example</i>
Environmental	Adverse weather Terrain Airport conditions Heavy traffic/TCAS events Unfamiliar airports
ATC	Command events/errors Language difficulties Similar call signs
Aircraft	Aircraft malfunctions Automation events
Crew support	Dispatch events/errors Ground events/errors MNT events/errors
Operational	Time pressures Irregular operations Flight diversions Missed approaches
Cabin	Cabin events Flight attendant errors Passenger events

Nevertheless, under specific combinations of operational circumstances, flight crews have to manage overt threats because they pose risks to the operation.

2.3.13 Latent threats are not readily observable by the crew, but are concealed within the fabric of the system or the particular operation. They may also pertain to culture, both at the national and organizational, as well as the professional level. Their presence may, for example, manifest itself in the context of organizational policies and procedures. Latent threats are aspects of the system that predispose the commission of errors or can lead to an undesired aircraft state. Examples of these latent threats include ATC practices, qualification standards, industrial issues, the state of relationships between management and the workforce, and conflicting goals between commercial and safety objectives.

2.3.14 While the genesis of threats is outside the influence of the crew, it is important that training is designed to provide flight crews with tools to recognize threats that are prevalent and unique to their specific airline operations. Flight crews that are well equipped in terms of recognizing threats will be more successful in managing the potential errors that such threats might generate during flight operations.

### Error management

2.3.15 Within the TEM concept, flight crew operational error is defined as an action or inaction by the crew that leads to deviations from organizational or flight crew intentions or expectations. Operational errors may or may not lead to adverse outcomes. TEM defines five categories of errors:

- a) **Intentional non-compliance error.** Wilful deviation from regulations and/or operator procedures.
- b) **Procedural error.** Deviation in the execution of regulations and/or operator procedures. The intention is correct but the execution is flawed. This also includes errors where the crew forgot to do something.
- c) **Communication error.** Miscommunication, misinterpretation or failure to communicate pertinent information within the flight crew or between the flight crew and an external agent (e.g. ATC or ground operations).
- d) **Proficiency error.** Lack of knowledge or psychomotor (“stick and rudder”) skills.

- e) **Operational decision error.** A decision-making error that is not standardized by regulations or operator procedures and, as such, unnecessarily compromises safety. In order to be categorized as a decision error, at least one of three conditions must have existed. First, the crew had more conservative options within operational reason and decided not to take them. The second condition is the decision was not verbalized and therefore not shared between crew members. The last condition is the crew had time but did not use it effectively to evaluate the decision. If any of these conditions were observed, then it is considered a decision error in the TEM framework. An example would include a crew’s decision to fly through known wind shear on an approach instead of going around.

2.3.16 If the crew is unable to avoid, trap or mitigate the error (i.e. unmanaged errors), the consequential outcome may lead to an undesired aircraft state. Typical situations that define an undesired aircraft state are incorrect aircraft configurations, unstable approaches, and vertical, lateral or speed deviations.

## 2.4 GUIDANCE FOR INTEGRATING TEM INTO CRM

### The threat-error-response-outcome concept

2.4.1 The threat-error-response-outcome concept involves the process of recognition by the crew of the threats that are either present (overt) or hidden (latent) in particular operational circumstances. Through the use of countermeasures, which include CRM skills, the crew must be able to determine courses of action to eventually manage threats, contain the errors and ultimately fly the aircraft safely to its destination — a safe outcome. In most cases, crews arrive at safe outcomes. As a result of sound foundations in technical skills or “learned” crew coordination skills, threats are recognized and errors are managed. This is a typical normal flight.

2.4.2 TEM is concerned with what happens during these typically “normal” flights where numerous learning opportunities abound. The use of the threat-error-response-outcome concept identifies aspects of how the crew manages the situation through the use (or misuse) of countermeasure skills. This concept sets the structure for the CRM training.

2.4.3 Using the Example on page 2-2-14, events occurring in an otherwise normal flight can be analysed using the threat-response-outcome concept. What are the

threats in this Example? How did the crew detect the threats and apply the appropriate response countermeasures? What errors did the threats generate? Finally, what was the outcome of the flight? These are the basic questions that should be considered while integrating TEM into a CRM programme. The Example also provides a TEM-based analysis of the above typical “normal” flight, using the threat-error-response-outcome concept.

### CRM training and development phases

#### Scope

2.4.4 Systematic CRM programme development demands a disciplined process of gathering operational data; training design, implementation and evaluation; and, lastly, integrating systems or procedural changes that improve flight safety. The following section discusses recommended practices for the development and integration of CRM in all aspects of flight operations. These are especially useful in planning and maintaining CRM programmes. The four phases of CRM training programme development are:

- a) assessment of operational experience;
- b) awareness;
- c) practice and feedback; and
- d) continuing reinforcement and development.

#### Assessment of operational experience

2.4.5 Operational experience defines training needs and therefore sets the stage for the other phases of training development. A key element of this phase is the identification or assessment of significant threats and errors that uniquely occur in the operator’s own flight operations system. Such an assessment should provide a thorough diagnosis of flight operations.

2.4.6 Diagnosis is best achieved by securing joint operational personnel and management participation and engaging them in free and open discussions. Many operators that have ongoing CRM training have utilized steering committees to assess operational experience.

2.4.7 In order to arrive at a comprehensive diagnosis, the following are elements that must be explored by an operator:

- a) threats and errors that have the potential to increase risks to safety in flight operations;

- b) countermeasures that are employed by flight crew members to address threats and errors;
- c) survey of crew performance attitudes (may be conducted across the flight operations department);
- d) data from other departments (ramp, customer service, cabin crew services and engineering) that indicate risks to flying operations; and
- e) safety data on the operator’s incident or event database.

2.4.8 There is no substitute for proper diagnosis. A comprehensive assessment of threats and errors drives training design and development and also ensures that the operator achieves a balanced view when planning for the CRM training programme. The Line Operations Safety Audit (LOSA) assists in arriving at a global review of operational threats and errors, thus maximizing the effectiveness of CRM training.

2.4.9 A proper assessment of operational experience includes data about how the airline manages its business of flight operations. Data on operational experience is about factors that shape an airline’s flying operations. What type of route structure does the airline have? Is there a preponderance of short-haul or long-haul fleet operations? What is the mix of expatriate and national pilots on the flight deck? What is the history of management and workforce interaction? Are there patterns of errors that can be gleaned from the airline incident database? Do employees speak up on safety concerns? These are some of the typical sources of data on an airline’s operational experience. Operational experience is important because it moulds the way an organization behaves in the face of threats.

2.4.10 Integrating TEM into CRM stresses the discipline of acquiring data on operational experience that will determine the effectiveness of CRM training (see Table 2-2).

#### Awareness

2.4.11 This phase defines the “foundation” CRM training. The objective is to educate crews on CRM countermeasures. It is a critical component of the training because this phase maps the design and method of the CRM training programme. The awareness phase include the following strategies:

- top management endorsement/buy-in of the programme;

**EXAMPLE**

During the after start flow, the first officer forgot to turn on the packs to pressurize the aircraft. This would have been caught in the after start checklist, but this item was inadvertently omitted; the flight was previously delayed for two hours and was running late on its assigned departure slot. At 8 000 feet into the climb, both pilots noticed that the aircraft was not pressurized. The first officer promptly corrected the error. The captain and first officer debriefed each other after the flight. The cabin crew was duly informed.

**Threat/response**

*What threats were present? What were the overt threats? What were the latent threats?*

Previously delayed flight — time pressure — increased workload of the crew — overt threat.

*How did the crew recognize/not recognize the threat?*

Did not recognize the threat.

*What actions did the crew take to address the threat?*

None.

**Outcome**

Threat was mismanaged.

**Error/response**

*What errors did the threat generate? How can these errors be described (procedural/communication/aircraft handling/decision/intentional non-compliance?)*

- First officer inadvertently omitted an item on pressurization from the after start checklist (procedural).
- Captain was not able to detect and cross-check the omission (procedural/communication).

*How did the crew recognize/not recognize the error/ undesired aircraft state?*

Both pilots noticed the aircraft did not pressurize only after they failed to complete the checklist, thus leading to an undesired aircraft state because there was a failure in a procedural countermeasure.

*What actions did the crew take to address the error? What happened after the crew took action? Was it consequential (another error occurred)? Was it inconsequential? What further actions did the crew take?*

- First officer promptly corrected the problem, switching the pack switch on.
- Crew was able to trap the error.
- Pressurization issue was resolved.
- Errors were consequential but the undesired aircraft state was managed.
- Cabin crew was informed.
- The crew debriefed each other.

**Outcome**

Error was mismanaged; undesired aircraft state was managed.

**Overall outcome**

Safe flight.

- line management buy-in and participation;
- union buy-in and participation;
- line employee buy-in and participation;
- completion of a “foundation” CRM training design;
- selection, training, quality assurance and development of CRM instructors;
- planning for training strategies;
- involvement of the regulatory authority in CRM development; and
- planning for CRM training evaluations.

2.4.12 The most essential element in effectively establishing CRM programmes is the deliberate endorsement of top management. Top management not only provides the resources for CRM training but, more importantly, provides the organizational support to sustain the CRM programme.

2.4.13 Endorsement is facilitated if top management is made aware of the role of CRM with respect to threat and

error management. This is where TEM stands out as a viable economic option for the airline — an organization that is aware of threats to its operations, and deliberately manages them through the use of CRM countermeasures, will certainly derive economic benefits. In this sense, CRM based upon threat and error management has the potential to support a good business case.

2.4.14 Experience indicates that using line pilots as CRM training instructors produces extremely positive results because line pilots live with threats and errors in operations. To a great extent, incorporating line pilots’ experience into CRM training boosts the effectiveness of that training. However, the benefits of using line pilots depend on establishing sound selection criteria. CRM instructors must be credible, technically proficient, and demonstrate good facilitating skills. Selection of ineffective instructors will have long-term damaging effects on CRM training. Operators must maintain CRM instructor selection criteria that should be continuously reviewed. Aside from setting selection criteria, a process must be established to constantly monitor and maintain the quality of CRM training. Once selected, CRM instructors must be included in development programmes in order to maintain appropriate facilitating skills.

**Table 2-2. Data on an airline’s operational experience**

<i>Operational experience</i>	<i>Sources of data</i>
How an airline manages:	
Threats	Operational hazard reports Trip/journey reports Confidential incident reports Cabin events; flight schedules Maintenance events Aerodrome/airport data Crew surveys
Errors	Incident Investigation Reports Simulator training assessments Flight Operations Quality Assurance (FOQA) data Confidential incident reports LOSA



### **Practice and feedback**

2.4.15 The practice and feedback phase involves two processes. The first process entails the demonstration of CRM countermeasure skills in applied operational contexts. An earlier statement now requires more in-depth discussion. Validation of CRM training success by using the decrement in accident rates per millions of flight sectors is of little use because accident rates are very low. Additionally, there is immense variability in pilot training, and it is impossible to trace which programme had a positive (or deleterious) effect on an accident. What is known through research is that crews that accept the training and demonstrate CRM countermeasure skills in managing errors have a greater likelihood of not being involved in occurrences.

2.4.16 In extreme cases, in prominent accidents such as the DC-10 that experienced total catastrophic hydraulic failure, CRM countermeasure skills were cited as averting larger loss of life. The second and perhaps more important process is the demonstration of the use of feedback on crew performance in the operational setting. In this regard, the value of LOFT in a non-jeopardy training session is emphasized. Non-jeopardy training is essential so that crews can manifest attitudes that are as close as possible to those that would be demonstrated in unmonitored conditions, during normal flights. Under these conditions, a trained evaluator or inspector can detect the trainee's learning of CRM countermeasure skills. On the other hand, the training organization can exercise flexibility in simulating typical and airline-specific scenarios that are representative of the operations and thus meaningful to the trainees.

2.4.17 In recent years, a new programme to monitor airline flight safety has emerged — the Line Operations Safety Audit (LOSA) — which offers great promise for assessing the use and validity of professional competencies and countermeasure skills, both CRM and technical, to address human error.

2.4.18 LOSA operationally reviews or audits a "slice" of an airline's flight operations, including flight crew performance — how crews recognize and manage threats and errors in normal line flights. In the end, an airline is given a "health check" report. One of the components of LOSA is to evaluate the extent to which a crew uses CRM to avoid, trap or mitigate errors. This is done through a systematic, non-threatening and unbiased observation of sampled flights by a trained LOSA observer. Apart from identifying CRM training effectiveness, LOSA has immense value in enhancing an airline's flight operations quality assurance (FOQA) programme. Practice and feedback elements further include:

- demonstration of CRM skills during simulator training;
- line checks conducted by the flight standards department;
- CRM/LOFT sessions;
- the use of LOSA as a process to validate the learning of CRM countermeasure skills; and
- the establishment of CRM recurrent training, which includes building CRM into command development programmes and reinforcing it in co-pilot development.

2.4.19 While the cornerstone of CRM training is the use of line pilots as CRM instructors, the most important individual in the practice and feedback phase is the inspector/check airman. Inspectors and check airmen must undergo a more specialized form of instructor training. This training should be focused on proper debriefing skills, knowledge of operator-specific threats, and LOFT debriefing techniques, such as the use of videotapes for reviewing crew performance. CRM recurrent training must also take place during the practice and feedback phase. It is where more specific CRM topics are discussed, or additional topics from the CRM awareness phase need to be further emphasized.

### **Continuing reinforcement and development**

2.4.20 Effective TEM is based upon operational experience. Using such experience during continuing reinforcement and development of CRM training is essential. The operational experience of each airline is unique and is likely to differ significantly from others. Airlines have distinct cultures, fly different routes and different fleets and are overseen by different civil aviation authorities, with specific practices in the implementation of Standards and Recommended Practices (SARPs). The use of the airline's own data produces relevant training programmes. Exhaustive examination of actual airline events, and their inclusion in CRM training, delivers the best results.

2.4.21 The use of TEM as the basis for CRM development allows flight crews to assess and manage threats. Flight crews should be given maximum opportunity during training to explore errors and examine effective and ineffective error management techniques. This is a key characteristic of TEM-based CRM training. To achieve this, it is important to provide a direct link between the safety

performance of the airline and the development and continuing design of CRM training. Relevance of the training programme is enhanced when actual events experienced by the airline are integrated into the CRM training in the form of case studies. By doing so, pilots are alerted to operator-specific threats that are experienced by others in line operations. Most important, CRM training becomes a venue for sharing countermeasures that have worked.

2.4.22 Training delivery is also an important training requisite. CRM should at all times remain operationally focused. This means the avoidance of training activities that have nothing to do with the operational environment. Classroom “games” must be absolutely avoided. Delivery techniques that should be used in CRM training revolve around an adult-learning context. This means that there must be a balance between “telling” and “facilitating” the learning. In general, delivery techniques such as small group discussions, use of incident/accident videos, and presentations that centre on real line-experiences offer the best learning opportunities for trainees.

### Summary

2.4.23 Table 2-3 summarizes the four phases of the development and implementation of CRM training and provides the CRM training developer with a checklist of elements and key items to guide CRM design and development.

### Rationale for the use of TEM

2.4.24 There are two basic reasons underpinning the use of TEM as a tool for CRM course design. First, threats and errors are present in all phases of flight operations. From the moment a flight is dispatched to the moment it terminates, pilots have to contend with threats and errors. Second, it follows that safe flight operations require the recognition of threats and the appropriate use of error management countermeasures to avoid, trap and mitigate the effects of human error. Building a course design using TEM creates a natural fit with CRM countermeasure skills. Table 2-4 summarizes how TEM can be used as guidance in outlining CRM course contents as well as learning outcomes.

2.4.25 Table 2-4 can be used to set the core knowledge and skills that need to be translated into an operator’s CRM course. The CRM countermeasures listed represent the combined expertise of practitioners and research in different countries. Aviation is a global activity, and although

there may be differences in the manner in which an operator manages its flight operations, the basic processes are very much the same. The CRM skills proposed are applicable to any operator, regardless of size and complement. Additionally, while cultural patterns differ among operators and among States, the CRM skills outlined will vary only insofar as emphasis.

### CRM skills to be developed

2.4.26 The following lists the different skills and appropriate competencies that govern the scope of CRM training:

- **Leadership/command.** Uses appropriate authority to ensure focus on task and crew member concerns. Supports others in completing tasks.
- **Decision making.** Detects deviation from desired state, assesses the problem, generates alternative actions, identifies risks and selects the best course of action. Subsequently, reviews the chosen course of action for the purpose of learning and changing the behaviour.
- **Communication.** Exhibits clear and effective use of language and responsiveness to feedback; plans are stated and ambiguities resolved. This is particularly demonstrated in ensuring interactive briefings and debriefings.
- **Situation awareness.** Comprehends present system and environmental conditions and anticipates future changes during the flight. Has the ability to project changes that may occur as the flight progresses.
- **Team-building.** Establishes task priorities and utilizes crew resources to achieve objectives. Contributes to the improvement of crew interpersonal relations.
- **Workload management.** Prioritizes and delegates effectively to maintain focus on primary tasks. Keeps everyone “in the loop” by actively communicating. Continuously monitors the progress of the flight.
- **Vigilance.** Consciously avoids complacency during the flight. Keeps watch over system and environment changes and informs other crew members of potential threats and errors.

Table 2-3. Elements and key items to guide CRM design and development

<i>Phase</i>	<i>Element</i>	<i>Key items</i>
Assessment of operational experience	<ul style="list-style-type: none"> <li>Assess/diagnose threats and errors that depict operational experience, including typical countermeasures practised in line operations</li> <li>Acquire crew performance data through simulator training, surveys and focused discussions among pilots, instructors and management</li> <li>Make available operational safety data from the operator's safety database, LOSA and FOQA</li> </ul>	<ol style="list-style-type: none"> <li>Identify overt or latent threats experienced in flying operations: <ul style="list-style-type: none"> <li>use LOSA data to develop scenarios for CRM training modules;</li> <li>use FOQA data to develop an overview of the operator's flight record.</li> </ul> </li> <li>If LOSA or FOQA data are not available, use significant incident reports that highlight threats and how crews manage errors.</li> <li>If historical, documented data are not readily available, conduct focus group sessions to identify representative threats and errors and how they are managed in flight operations.</li> <li>Prioritize safety issues that should be urgently addressed during CRM training and build priorities into the CRM training design.</li> <li>Collect data from other operational groups such as cabin crew, engineering, ramp operations, and customer services about threats and errors that impact on flying operations and build them into the CRM training design.</li> <li>Integrate a design group that shall be in the best position to design CRM training, and appoint a programme manager to direct the CRM training design.</li> </ol>
Awareness	<ul style="list-style-type: none"> <li>Secure a commitment by top management to CRM implementation</li> <li>Complete CRM training design and training delivery including a plan for selection and development of CRM instructors</li> <li>Plan for CRM training evaluations</li> </ul>	<ol style="list-style-type: none"> <li>Highlight the impact of CRM on business goals, e.g. impact of on-time performance pressures on safety and CRM.</li> <li>Involve the civil aviation authority in CRM development. This includes maintaining a process to keep the civil aviation authority informed and in the loop.</li> <li>Develop a safety management system and method for maintaining CRM learning as applied in line operations. This involves actual transfer of CRM skills into line operations.</li> </ol>
Practice and feedback	<ul style="list-style-type: none"> <li>Integrate CRM skills into simulator and line training</li> <li>Ensure that command pilot and co-pilot development courses include the assessment of CRM skills</li> <li>Ensure that flight and simulator instructors understand and apply CRM in both instructing and checking</li> </ul>	<ol style="list-style-type: none"> <li>Institute a process for assessing CRM skills, together with technical competency requirements.</li> <li>Coordinate the integration of CRM skills into command pilot and co-pilot development.</li> <li>Plan and implement a continuing data collection programme on threats and errors that are observed during simulator training or line checks.</li> <li>Ensure that flight and simulator instructors maintain the required standards in assessing CRM skills.</li> </ol>
Continuing reinforcement and development	<ul style="list-style-type: none"> <li>Develop a plan for communicating threats and errors in line operations</li> <li>Link safety performance with continuing CRM training development</li> <li>Effectively use research data to improve and refresh CRM training</li> </ul>	<ol style="list-style-type: none"> <li>Generate a feedback process whereby threat and error countermeasures are communicated to all pilots.</li> <li>Identify options for using operator safety incidents to maintain currency and relevance of CRM training.</li> <li>Explore the use of survey and safety information data to improve the CRM training.</li> <li>Use simulator and line check performance to improve CRM training.</li> </ol>

**Table 2-4. Integrating TEM in course design**

CRM teaching module	Learning outcomes
<div style="border: 1px solid black; width: 150px; height: 100px; margin: 0 auto; text-align: center; line-height: 100px; font-weight: bold; font-size: 1.2em;">THREAT</div> <div style="text-align: center; margin: 10px 0;">↓</div> <div style="border: 1px solid black; width: 150px; height: 50px; margin: 0 auto; text-align: center; line-height: 50px; font-weight: bold; font-size: 1.2em;">RESPONSE</div>	<p><i>Recognition of threats</i></p> <ul style="list-style-type: none"> <li>• Latent                      Demonstrates an understanding of national, professional and organizational cultures, policies and regulations and their relationship in terms of potential threats to flight operations.</li> <li>• Overt                        Is aware of team, individual, organizational, systemic and aircraft-related threats through knowledge of operator's unique experiences.</li> </ul> <p><i>Team and climate countermeasures</i></p> <ul style="list-style-type: none"> <li>• Leadership/ command                      Is decisive even in ambiguous situations. Seeks consensus and participation.</li> <li>• Communication                                Shows clarity in delivery of messages and practices active listening skills. Checks for understanding and seeks feedback.</li> <li>• Team-building                                    Defines crew members' responsibilities and sets direction. Uses coaching skills to motivate crew members.</li> </ul> <p><i>Execution countermeasures</i></p> <ul style="list-style-type: none"> <li>• Workload management                      Has the ability to prioritize tasks and keeps a constant check for crew overload.</li> <li>• Vigilance                                        Remains alert of the environment and aircraft position.</li> <li>• Automation management                    Demonstrates a balance between workload and automation. Relegates less prioritized tasks to automation.</li> <li>• Human performance and human error                      Maintains alertness but is aware of individual limits. Recognizes personal stress and seeks assistance when needed.</li> </ul> <p><i>Planning</i></p> <ul style="list-style-type: none"> <li>• Briefings                                        Practices thorough operational briefings and includes other crew members such as cabin crew. Checks for understanding.</li> <li>• Setting bottom lines and limits                      Is aware of the demands of the task. Sets ample time to complete the task and does not digress from task objectives.</li> <li>• Contingency management                      Anticipates and plans for unforeseen events.</li> </ul> <p><i>Review and monitoring</i></p> <ul style="list-style-type: none"> <li>• Evaluation of plans                              Reviews and modifies plans when necessary. Seeks participation from other crew members.</li> <li>• Inquiry    Seeks information and queries if information is vague or incomplete.</li> <li>• Assertiveness                                    Appropriately communicates opinions about a decision and verbalizes concern if needed.</li> </ul>

- **Automation management.** Uses automation to assist in managing the flight especially in high workload situations. Keeps track of mode changes and “keeps ahead of the curve”.
- **Human performance.** Is aware of personal and human limitations, recognizes stress loads and is assertive when approaching personal/human limitations.
- **Briefings.** Sets open and interactive communication. Checks the understanding of others by soliciting questions or comments. Focuses briefings on operational issues.
- **Setting bottom lines.** Is aware of crew actions, especially potential breaches of minima. Verbalizes concerns and opinions if risks increase the vulnerability to error during the flight.
- **Contingency management.** Maintains constant awareness of change in the progress of the flight. Assesses threats and plans for contingent actions to meet constraints that may develop in the flight.
- **Evaluation of plans.** Examines the course of action taken. Solicits input from other crew members to analyse how threats and errors were managed and how crew performance can be improved in the future.
- **Assertiveness.** Queries others especially during ambiguous situations to clarify actions to be taken. Constructively asserts views and contributes to overall team effectiveness.

## 2.5 LINE-ORIENTED FLIGHT TRAINING (LOFT)

### Introduction

2.5.1 Line-oriented Flight Training (LOFT) refers to non-jeopardy, facilitated aircrew training which involves a full mission simulation of situations which are representative of line operations. LOFT places special emphasis on situations that involve communications, management and leadership. In short, LOFT means realistic, real-time, full mission training. The assessed value of LOFT is such that several States' aviation administrations permit its use instead of the usual semi-annual proficiency checks, provided that certain specified conditions are met.

2.5.2 LOFT can have a significant impact on aviation safety through improved training and validation of operational procedures. LOFT presents to aircrews scenarios of typical daily operations in their airline with reasonable and realistic difficulties and emergencies introduced to provide training and evaluation of proper flight deck management techniques, the threats the operational environment generates, and the threat and error management strategies employed by flight crews. The result is an appreciation by the airline of operational shortcomings on the part of line crews and an evaluation of the adequacy of flight deck procedures, as well as overall crew training effectiveness.

2.5.3 LOFT scenarios may be developed from many sources, but accident and incident reports provide a realistic and appropriate starting point. A properly conducted LOFT programme can provide great insight into the internal workings of an airline's operations and training programme for the following reasons:

- a) If similar errors seem to be recurring among pilots, it may indicate a potentially serious problem as a result of incorrect procedures, conflicting or incorrect manuals, or other operational aspects.
- b) It may reveal areas in aircrew training programmes which are weak or which need emphasis.
- c) It may reveal problems with instrument locations, information being presented to pilots, or other difficulties with the physical layout of a particular flight deck.
- d) Airlines can use it to test and verify flight deck operational procedures.

2.5.4 LOFT should not be used as a method of checking the performance of individuals. Instead, it is a validation of training programmes and operational procedures. An individual or crew needing additional training after a LOFT session should be afforded that opportunity immediately with no stigma or recrimination.

2.5.5 A LOFT session should not be interrupted except in extreme and unusual circumstances. Repositioning the simulator and repeating problems is inconsistent with the principles of LOFT. Part of the benefit of LOFT is derived from an individual or crew being able to quickly appreciate the results, either positive or negative, of operational decisions. After completion of such a session, a thorough debriefing should be made of all aspects. This may be accomplished by an initial self-debriefing by the crew, followed by a debriefing by the LOFT coordinator (check

pilot, instructor). This critique should include the use of such aids as voice and video recorders, as well as written notes.

### Development of scenario designs

2.5.6 Different operators, different operations and different pilots within an operation have different training needs. Legislation and regulations governing the use of LOFT must allow flexibility to permit the fulfilment of these different training needs. If a minimum number of simulator training hours is specified, an operator should be permitted to divide these hours among LOFT and training in other skills in order to accomplish the objectives deemed most important by that particular operator.

2.5.7 Full-mission simulation may be used for purposes other than LOFT. Many of the following guidelines for scenario development may also be appropriate for the design of other full mission simulation tasks. The primary factor that must govern the use of a full mission simulation is the specific objective for which it is being used and the specific context in which it is being applied.

2.5.8 All LOFT scenarios and flight segments should be designed on the basis of a detailed statement of specific objectives. These objectives must state what kind of situation is to be addressed and why.

2.5.9 The origin, routing and destination of a particular scenario should be dictated by the specific objectives for that scenario or flight sector. Other factors to be considered are the weather, operational and equipment problems, etc. Simulator visual systems, as well as other capabilities and limitations, must be considered at a very early stage of scenario design. The simulator navigation area must be appropriate and must coincide with current charts. Similarly, current manuals and other operational documentation must be available to preserve realism.

2.5.10 Other factors to be considered are alternate airports, fuel, and air traffic control. The specifics of location choice will depend on the operator's needs. For example, if a situation is to be constructed around an air traffic control problem, one must choose a route where that problem is likely to occur.

2.5.11 Problems and anomalies should be chosen in terms of the specific objectives. Both simple problems (those that have no impact on the flight once they have been diagnosed and corrected) and complex problems (those that

exert an influence on the remainder of the flight) may be used. Problems should not be compounded. The simultaneous presentation of multiple problems should not result from scenario design, although it may occur as a result of inappropriate crew action. LOFT scenarios should not be designed to bury or overload the crew. An accident should never be inevitable, although it is an outcome that may occur.

2.5.12 Subscenarios should be designed in order to anticipate crew actions as much as possible. It is wise to limit the crew's options to some extent. The LOFT instructor should be in a position to follow alternative options to a reasonable conclusion in many cases. The use of problems that cannot be corrected is permissible if those problems are appropriate to the objectives of the scenario. An example would be failure of the landing gear to extend, resulting in a gear-up landing.

2.5.13 The pacing and tempo of a scenario must be appropriate to certain factors such as the location, the departure time and the phase of flight. Most importantly, it must be appropriate to the specific objectives of that scenario. Designers should avoid totally filling a flight period. They should leave some time for lulls and periods of relative inactivity. The pacing of anomalies and other events must not detract either from the realism of the scenario or from the training potential of the situation.

2.5.14 Scripts should be designed in as much detail as possible in order to simulate the real world. A lack of detail requires the LOFT instructor to improvise, which takes considerable time away from observation and evaluation of the crew. Such improvisation may also fail to accomplish the specific objectives of the scenario.

2.5.15 Communications under the control of the LOFT instructor should be specified verbatim. The pacing and timing should be built in. Problem timing and input should be specified. Whenever a problem is injected, all anticipated crew actions should also be included in the scenario. Alternatives should also be specified where appropriate to modify the timing of a scenario. For example, if the crew executes an unexpected missed approach, an alternative course of action for the next leg may be necessary in order to stay within simulator time constraints. The LOFT instructor may not add to or modify a scripted situation, but if the crew is observed to be so overloaded that further learning is impossible, reasonable judgement should be exercised to prevent further compounding of the crew's situation.

2.5.16 In the area of scenario revision and quality control after development, the scenario must be tested.

Revisions will almost always be required. Even after further testing and, when required, approval by the aviation authorities, use of a scenario may reveal details that require further revision based on input from LOFT instructors and line flight crews.

2.5.17 All scenarios must be kept current with respect to navigation, communications, regulations, company procedures and aircraft modifications. Accuracy of the scenarios with respect to hardware and software is essential to the credibility of LOFT.

2.5.18 Procedures and practices in the flight operations manuals or flight crew operating manuals that are known to be frequently misunderstood should be considered for inclusion in a LOFT scenario. For this purpose, also consider accident and maintenance reports, as well as incidents taken from information exchanges and confidential reporting systems.

2.5.19 Under operational problems, include pre-flight, dispatch release, hazardous cargo, fuelling options, NOTAM, etc. Minimum equipment list (MEL) items, as well as cabin/passenger problems, ATC problems and mass and balance problems are all good sources for LOFT scenarios. Under environmental problems, include weather, wind, temperature, runways that are wet, icy or closed and runway and touchdown zone lighting problems, as appropriate.

2.5.20 In the equipment problems category, include, as appropriate, airborne equipment problems and ground equipment problems such as support equipment and ground-based radio aids. Under crew problems, include cabin crew problems and flight crew problems including incapacitation, either obvious or subtle.

2.5.21 Also consider other uses of a full mission simulation. It offers promise for several applications in training and other areas of interest to operators. The design of such simulations will depend on the specific objectives to be attained. Examples of the areas in which a full mission simulation can be of value are: initial training of new pilots, upgrade and transition training, and evaluation of new procedures.

#### **Performance evaluation and assessment**

2.5.22 There is an apparent conflict inherent in the purpose versus the application of LOFT. To be effective, it

must be accepted by the crew members and administered by the instructors as pure training. There is no such thing as a "no jeopardy" training exercise, since operators are charged with the responsibility of continuing training for those who require it. It is, however, essential that an atmosphere be created which allows the crew members to enter the training with a feeling of freedom, openness and enthusiasm. Reserve or defensiveness because of concern for failure must not inhibit participation.

2.5.23 To a considerable extent, conflict can be minimized by the manner in which the instructor sets the scene during the pre-flight briefing, when it should be emphasized that:

- it is a purely a learning experience;
- it is a training concept designed to emphasize crew command, coordination, communication, and full management of the available resources;
- the instructor will not interfere regardless of developments;
- errors may be made, but the crew should carry on since there is no one book solution to a LOFT exercise;
- there will be an opportunity for a full self-analysis during the debriefing; and
- the instructor will take notes during the exercise and will assist in the debriefing.

2.5.24 The role of the instructor is not that of an instructor in the traditional sense. For example, realism considerations dictate that the instructor will not intervene or intrude in any way into the LOFT scenario. Thus, for purposes of the debriefing, it is crucial that the instructor serve primarily as a facilitator of learning.

2.5.25 In the experience of operators who use LOFT to good advantage, crews tend to debrief themselves. Self-criticism and self-examination are normally much more effective than a critique led by the instructor. In fact, crews are often much harder on themselves than the instructor would ever consider being. The instructor should do everything possible to foster such self-analysis.

2.5.26 The instructor can guide the discussion to points that need attention. Questions about certain procedures, mistakes, and so forth, should be asked whenever

possible, and unless absolutely necessary, lectures about what is right and what is wrong should be avoided. A suggested format for the debriefing should include:

- a positive general statement or “welcome” opening the discussion;
- a short review of the scenario, including the objectives;
- a discussion by crew members of the operation as a whole and in part;
- coverage of all aspects of the flight, not permitting any one feature to dominate the debriefing;
- reference to possible alternatives and better ways of accomplishing the objectives; and
- further development of the discussion through the use of questions to each crew member, such as “what if you had done ...”.

2.5.27 With respect to evaluation and assessment, everything should be done to assure crews participating in LOFT that their jobs are not in jeopardy every time they enter the simulator for a LOFT session. While satisfactory completion is an inescapable aspect of LOFT, at the same time it is hard to imagine unsatisfactory training. In some cases, LOFT may underscore areas that need extra attention, but often even serious mistakes made during LOFT are obvious and need no further attention if the learning provided by the experience cannot be improved upon. However, in some cases, mistakes may indicate deficiencies that need additional work. The manner or way that this is conveyed to a crew member is of vital importance and represents a challenge to the operators and their instructors.

2.5.28 During debriefing, total crew performance and individual performance should both be openly discussed and assessed by the instructor. Critical assessment of an individual must be mentioned in the presence of the full crew, but remedial details should be handled separately. Tact is required to maintain the proper training atmosphere.

2.5.29 LOFT is, first and foremost, a learning experience. The success and acceptance of a LOFT programme depends in great measure on its planning and preparation. Scenarios must emphasize realism. Instructors should be carefully selected and trained in the art of briefing, conducting the programme and debriefing.

2.5.30 Additional training for crew members, when indicated, must be handled in a low-key, non-threatening manner. If these factors are carefully handled, the evaluation/assessment chore will not necessarily detract from the pure training atmosphere and will result in full acceptance.

### **Instructor training and qualifications**

2.5.31 Each instructor should have completed a specific LOFT training course. Generally, instructors are selected from line pilots or check pilots flying the type of aircraft on which the LOFT training is given.

2.5.32 Some airlines are successfully using former pilots who have extensive airline experience but who are no longer current. In this case they should receive the ground and simulator part of the type-rating training course for the applicable type of aircraft. They should also be familiar with the current line operational procedures and should regularly ride the jump seat on typical line segments to observe operating procedures.

2.5.33 Where LOFT training involves a crew of three, the airline should have the flexibility of conducting the LOFT training with one instructor appropriately trained for all crew positions.

2.5.34 The role of the instructor should be confined to the following:

- pre-flight briefing;
- accurate conduct of a prescribed scenario in a realistic manner;
- monitoring, recording, and assessment of crew performance for the debriefing; and
- performance of an objective debriefing, encouraging the use of self-critique to its maximum advantage.

### **Specialized training for instructors**

2.5.35 Instructors and check pilots selected to conduct LOFT exercises should receive training in the concepts and conduct of LOFT. Such training would include but not be limited to:

- the conduct of the crew briefing and complete familiarity with all pre-flight procedures, including



- flight plans, weather reports, minimum equipment lists, aircraft performance data, aircraft loading procedures, etc.;
  - the observation and understanding of threat and error management, crew concepts and crew coordination;
  - the pacing and selection of items in the LOFT scenario and the introduction of abnormal and emergency procedures or situations;
  - an in-depth understanding of observation, communication, command and leadership skills;
  - development of the individual's own skills in interacting appropriately with the flight crew during the briefing, the LOFT exercise and the debriefing; and
  - training in assessment skills with appropriate guidance in specific areas such as the exercise of command responsibilities, planning, organization, interpersonal communications, problem-solving, decisiveness, judgement, knowledge of aircraft systems and performance, knowledge of and compliance with aviation regulations and ATC procedures, sensitivity, leadership, assertiveness, smoothness and flying skill, work standards and crew coordination.
- transition or initial training;
  - developing familiarity with special airports;
  - remedial training;
  - wind shear problems;
  - accident and incident investigations;
  - introduction of new pilots to communications, clearances, check-list duties and route flying;
  - evaluation of cockpit controls and flight instruments and the assessment of Human Factors aspects in the cockpit design;
  - first officer training, such as VFR approach and departure techniques, and traffic patterns;
  - fuel management and assessment;
  - development of techniques and procedures;
  - development of take-off and landing skills;
  - accident and incident scenario reviews;
  - engine-out ferry training and qualifications;
  - pre-mission reviews for special operations; and
  - special handling training, such as high altitude stalls.

### Standardization of LOFT

2.5.36 Standardization of LOFT is achieved if instructors are given a complete training programme at the outset, followed by periodic monitoring. Additionally, a feedback and critique programme using flight crew members is essential if such a programme is to work. Instructor standardization is improved if LOFT instructors monitor each other. Standardization can be achieved if the LOFT instructor group is small and works almost exclusively on the LOFT programme. LOFT should not be conducted by anyone other than properly qualified instructors, but they may perform other functions within a training department if necessary. Regular standardization meetings should be scheduled. During these sessions, LOFT scenarios can be assessed and re-evaluated for improvement.

### Other uses for a full mission simulation

2.5.37 The following is a list of other uses for a full mission simulation:

### Examples of LOFT scenarios

2.5.38 The following are two examples of LOFT scenarios that can aid CRM/LOFT design construction. Note that scenario design varies from company to company and that more specific scenario description, including timing, is required.

2.5.39 The examples are broken down into three parts. Each example begins with a brief description of the scenario, followed by the threats which impact on the crew and which have to be identified and resolved. It also includes a list of CRM/LOFT competencies and outcomes which reflect the learning which will be derived from the scenario itself. The latter is a key component of the CRM/LOFT scenario design because the LOFT facilitator/instructor can base the debriefing of the crew on that component.

**Scenario 1**

Reported bomb threat on board. This is a short sector flight from Singapore to Penang. About ten minutes from top of descent (TOD), the cabin crew reports that they have noticed a sealed package in the aft toilet compartment. Closer inspection reveals that the package contains a bomb.

<i>Flight phase</i>	<i>Scenario</i>	<i>Threats</i>	<i>CRM/LOFT competency and outcomes</i>
Pre-flight	Aircraft is over-fuelled but with no adverse impact on landing weight. Crew is informed of the situation fifteen minutes before estimated time of departure (ETD).	Change in aircraft performance  Pressure on the crew to depart	<i>Workload management.</i> New loadsheet requirement while keeping track of departure constraints and pressure. Flight departs.  <i>Communication.</i> Public address (PA) announcement to passengers and crew as appropriate.
Cruise	Moderate turbulence	Potential passenger and crew injury	<i>Vigilance.</i> Passengers and crew informed of turbulence in advance. Risks to injury avoided.  <i>Situational awareness.</i> Cabin crew instructed to notify flight deck of any eventuality arising from turbulence.
Ten minutes from TOD	Cabin crew reports to flight deck that a passenger has discovered a package in the aft toilet. It contains a bomb.	Bomb on-board  Progressive passenger and crew apprehension	<i>Decision making.</i> Optimum option selected with guidance from company procedures; company and ATC duly notified of threat.  <i>Contingency management.</i> Crew is engaged in best course of action to avoid undue panic of passengers.  <i>Situation awareness.</i> Close watch is kept for signs of escalating security dangers in the cabin.
Descent	Cabin crew reports that passengers in the aft cabin area are unmanageable. As a result, one passenger suffers a heart attack.	Death on-board  Multiple tasks with time compression  Unmanageable passengers	<i>Leadership and command.</i> Appropriate PA announcement is made.  <i>Decision making.</i> Decision is made to land as soon as possible.  <i>Communication.</i> ATC and company notified of situation and ground services requirements are put in place.  <i>Workload management.</i> Tasks are balanced between both crew members, and bottom lines are set; briefings and checklists are completed.
Approach and landing	ILS glide slope failure with 1 000 ft ceiling	Continuing passenger control on-board  Pressure as a result of ILS glide slope failure	<i>Briefings.</i> Alternative actions are discussed during briefing, noting what to expect after landing and on the ground.  <i>Workload management.</i> Minima reset and landing continued.

**Scenario 2**

This is a Zurich to Milan flight on a twin-engine widebody; the first officer is the pilot flying. The flight experiences engine failure on take-off. Key aspects of the scenario are the smooth transition of roles from the first officer to the captain and the use of automation to assist with safe flight objectives. Other threats to the flight will impact on crew performance.

<i>Flight phase</i>	<i>Scenario</i>	<i>Threats</i>	<i>CRM/LOFT competency outcomes</i>
Pre-flight	Normal; no significant impact on event. Perform normal checks and procedures. First officer's sector	Heavy weight take-off	<i>Briefings.</i> Performance considerations are discussed in view of terrain considerations.
Take-off	Engine failure after V <sub>1</sub>	Terrain avoidance	<i>Leadership/command.</i> Smooth transition of pilot flying and pilot not flying roles between first officer and captain.
		Role reversal	
		Asymmetric control of flight due to engine failure	<i>Communication.</i> Company and ATC informed.
Climb	Zurich Airport closes due to security. ATC recommends diversion to Frankfurt.	Passenger and crew apprehension	<i>Workload management.</i> Appropriate checklists are performed.
		Flight cannot land ASAP, compounding pressure	<i>Automation management.</i> Subordinate tasks are relegated to automation.
		Time elapsed after engine failure increases	<i>Communication.</i> Clear coordination of actions with the company and ATC; PA announcement to reassure passengers of the situation and safety issues.
Cruise	Diversion to Frankfurt	Passenger and crew apprehension	
		High workload with short diversion time	<i>Briefings.</i> Plans are communicated. Questions are encouraged.
Approach	Engine inoperative on approach and landing	Pressure to land ASAP after engine failure	<i>Communication.</i> Passengers and cabin crew are informed about the diversion and the situation at hand. Ample reassurance is verbalized.
		Non-normal approach and landing	<i>Automation management.</i> Uses automation to assist in approach and landing.

## LIST OF RECOMMENDED READING

- Dekker, S., and E. Hollnagel. 1999. *Coping with Computers in the Cockpit*. Aldershot, England: Ashgate Publishing.
- Hayward, B.J. and A.R. Lowe, eds. 1996. *Applied Aviation Psychology: Achievement, Change and Challenge*. Aldershot, England: Ashgate.
- Hawkins, F. 1993. *Human Factors in Flight*. 2nd ed. Brookfield, VT: Ashgate Publishing Co.
- Helmreich, R.L., A.C. Merritt, and J.A. Wilhelm. 1999. "The Evolution of Crew Resource Management Training in Commercial Aviation". *International Journal of Aviation Psychology*. 9(1), 19-32.(UTHFRP Pub 235).
- Helmreich, R.L. 1999. "CRM Training Primary Line of Defence Against Threats to Flight Safety, Including Human Error". *International Civil Aviation Organization (ICAO) Journal*. 54(5), 6-10, 29.
- Helmreich, R.L. 1999. "Ten Years of Change: Crew Resource Management 1989-1999". In *Proceedings of the Fourth ICAO Global Flight Safety and Human Factors Symposium* (pp. 139-149). Santiago, Chile: ICAO.
- Helmreich, R.L., J.R. Klinect and J.A. Wilhelm. 1999. "Models of Threat, Error, and CRM in Flight Operations". In *Proceedings of the Tenth International Symposium on Aviation Psychology* (pp. 677-682). Columbus, OH: The Ohio State University. (UTHFRP Pub 240).
- International Civil Aviation Organization. *Human Factors Digest No. 10 — Human Factors, Management and Organization*. (Circ 247). 1993. Montreal, Canada: International Civil Aviation Organization.
- Maurino, D.E., J. Reason, N. Johnston, and R. Lee. 1995. *Beyond Aviation Human Factors: Safety in High Technology Systems*. Brookfield, VT: Avebury Aviation.
- Orlady, H.W. and L.M. Orlady. 1999. *Human Factors in Multi-crew Flight Operations*. Aldershot, England: Ashgate Publishing.
- Reason, J. 1990. *Human Error*. Cambridge, England: Cambridge University Press.
- Reason, J. 1997. *Managing the Risks of Organizational Accidents*. Aldershot, England: Ashgate Publishing.
- Salas, E., C.A. Bowers, and E. Edens, eds. 2001. *Applying Resource Management in Organizations*. Mahwah, NJ: Lawrence Erlbaum Inc.
- Wiener, E L., B.G. Kanki, and R.L. Helmreich, eds. 1993. *Cockpit Resource Management*. San Diego, CA: Academic Press.
- Wiener, E. 1989. *Human Factors of Advanced Technology ("Glass Cockpit") Transport Aircraft*. NASA Contractor Report 177528. NASA Ames Research Center, Moffett Field, CA.
- Wiener, E. 1993. "Crew Coordination and Training in the Advanced-technology Cockpit". In *Cockpit Resource Management*. E. Wiener, B. Kanki, and R. Helmreich, eds. San Diego, CA: Academic Press.

# CHAPTER 3

## TRAINING ISSUES IN AUTOMATION AND ADVANCED TECHNOLOGY FLIGHT DECKS

### 3.1 INTRODUCTION

3.1.1 This chapter presents the Human Factors implications of automation and advanced technology flight decks. The purpose of the chapter is to identify operational and training issues, and to provide an understanding of the problems in the interface between humans and automation, with emphasis on the way in which automation affects human performance.

3.1.2 This chapter has an operational orientation, and it does not address issues of equipment design and certification since flight deck and systems design are discussed in Part I, Chapter 3. It is expected that these two chapters will contribute to the understanding of the problems faced by training personnel when new technology is introduced.

3.1.3 Automation has been gradually introduced in flight decks (and in the aviation system) over time. Flight deck automation has the potential to make aircraft operations safer and more efficient (a one per cent reduction in fuel consumption translates into annual savings of \$100 000 000 for the IATA carriers of one particular State) by ensuring more precise flight manoeuvres, providing display flexibility, and optimizing cockpit space. In the interest of flight safety, however, this chapter focuses on actual and potential problems and issues. This is because of the need to define and understand these problems, and it is not intended to be a reflection on the technology itself. To keep a proper perspective, it must be stated that the benefits of automation far outweigh the problems.

3.1.4 Although there is still no international consensus regarding the proper use of automation, there is no question that the reduction in accidents related to human error can, in part, be explained by the introduction of automation on the flight deck. However, the record also shows that failures of automatic equipment, and, more frequently, mismatches at the human-equipment interface, remain as crucial links in the causal chain of accidents and incidents.

3.1.5 One of the reasons for the introduction of automation was the elimination of human error. So far, it has been successful in the elimination of certain type of errors. But in other cases, what has taken place is a displacement of error. Experience indicates that while automation may eliminate small errors, it may increase the potential for large errors. These are examples of the messages which this chapter attempts to convey.

3.1.6 This chapter:

- presents the history of automation in aviation, proposes a definition of automation, addresses the evolutionary nature of automation, and stresses the need for an automation philosophy;
- addresses some of the problems of automation and illustrates what worked and what did not with regard to the expectations for automation;
- refers to the training of operational personnel with special emphasis on flight crew training;
- refers to management techniques and coping strategies, other than training, which have been or can be employed to solve automation problems;
- includes the field studies in automation completed to the present date;
- presents a set of automation principles;
- proposes an example of automation philosophy, as proposed by one operator; and
- presents a list of references.

### 3.2 AN INTRODUCTION TO AUTOMATION

3.2.1 The Oxford Dictionary defines automation as "automatic control of manufacture of product through successive stages; use of automatic equipment to save

mental and manual labour." For the purpose of this chapter, the following definition of flight deck automation is proposed: "the assignment to machinery, by choice of the crew, of some tasks or portion of tasks performed by the human crew to machinery. Included in this definition are warning and alerting systems that replace or augment human monitoring and decision-making (this may not be at the choice of the crew, but preassigned, such as systems monitoring, flight status monitoring, fire detection)."

3.2.2 Automation was initially aimed at stabilizing aircraft attitude through the control of aerodynamic surfaces. This need was met with gyroscopic devices, which were used in the maintenance of attitude for all spatial axes (aircraft inner loop control) for many years. During World War II, vacuum-driven gyroscopes, which also provided information on heading and attitude in the flight deck, were intensively used to provide better information, alleviate fatigue, and reduce manual control requirements.

3.2.3 Progress was fast after the war. Electrical systems and electronic amplifiers replaced vacuum-driven gyros. The introduction of very high frequency omnidirectional radio range (VOR) transmitters and the instrument landing system (ILS) permitted the coupling of autopilots to the output signals of this equipment and track radials, localizer and glide slope beams. Precise data regarding external references, integrated into the autopilot system, enhanced outer loop control<sup>1</sup>. This was the prevailing state of the art when commercial jet transports were introduced in the late 1950s.

3.2.4 The increase in speed and altitude capability of these new transports required a more accurate inner loop control — especially at high altitudes — as well as more precise flight instruments. Yaw dampers, to damp oscillations as well as to prevent the tendency to yaw away from banked turns, and Mach trimmers to counteract the tendency to pitch down at high Mach numbers, were introduced during this period, and are good examples of automatic devices used without crew intervention. The introduction of flight directors<sup>2</sup>, which integrated attitude and navigational information into a single instrument, provided better inner loop control, but at the same time raised concerns about pilots losing sight of the 'raw data' from which the information was derived.

3.2.5 Advances in solid-state electronics during the 1960s fostered the appearance of autopilot and flight director systems which made automatic landings possible, and allowed the integrated control of power and flight path through autothrottle systems. Reported difficulties by flight crews in learning to operate the more complex aspects of these systems led to the requirement to demonstrate

proficiency in their use during pilot certification, whereas previous requirements emphasized the ability to operate without these aids. The ground proximity warning systems (GPWS), and, more recently, the airborne collision avoidance system (ACAS/TCAS) represented a further extension of the concept of 'automated commands' advising the pilot to manoeuvre the aircraft, rather than using automation merely to maintain aerodynamic or navigational control. This philosophy of automated pilot advisory/warning prevails today in wind shear advisory and collision avoidance systems. The introduction of area navigation (RNAV) and four-dimensional flight management systems integrated with the autopilot increased the level of automation complexity prevailing in civil transport aircraft. It also expanded the capability of aircraft and air traffic control (ATC) to use airspace more effectively.

3.2.6 Economics, including the goal of reducing flight deck workload to permit safe and efficient utilization of two- rather than three-person crews, was a major driving force behind the next major step in flight deck automation: electronic cathode ray tube (CRT) displays and automated system management devices. (The relationship between automation and workload has yet to be established, however, and it is incorrect to accept as a general statement that automation reduces workload, since there are conditions under which the very opposite occurs.) The reduction of human error by monitoring the human management of aircraft systems and flight control was another major objective, as were optimizing flight performance and managing fuel consumption. Operationally, the new systems enabled vertical and horizontal automated navigation and guidance, as well as completely automatic thrust management. Yet the implications of this new technology were only beginning to be understood. As these aircraft were introduced, it was soon evident that the ATC system was not adaptive enough to permit full use of the capabilities of the newer aircraft flight management systems (FMS).

3.2.7 The recently introduced new aircraft (A320/330/340; B747-400; B777; MD-11) are equipped with advanced forms of automation, whose control systems incorporate logic to prevent the aircraft from exceeding its safe operating envelope. Through microprocessor technology, navigational tasks and aircraft system management have been automated, making the flight crew more peripheral to the actual operation of the aircraft. Pilots who at one time had direct authority over all aspects of aircraft control and management have now become responsible for the management of complex hardware and software interfaces, through which they are required to direct the operation of the aircraft (see Figure 3-1). These technological advances, however, have given rise to new

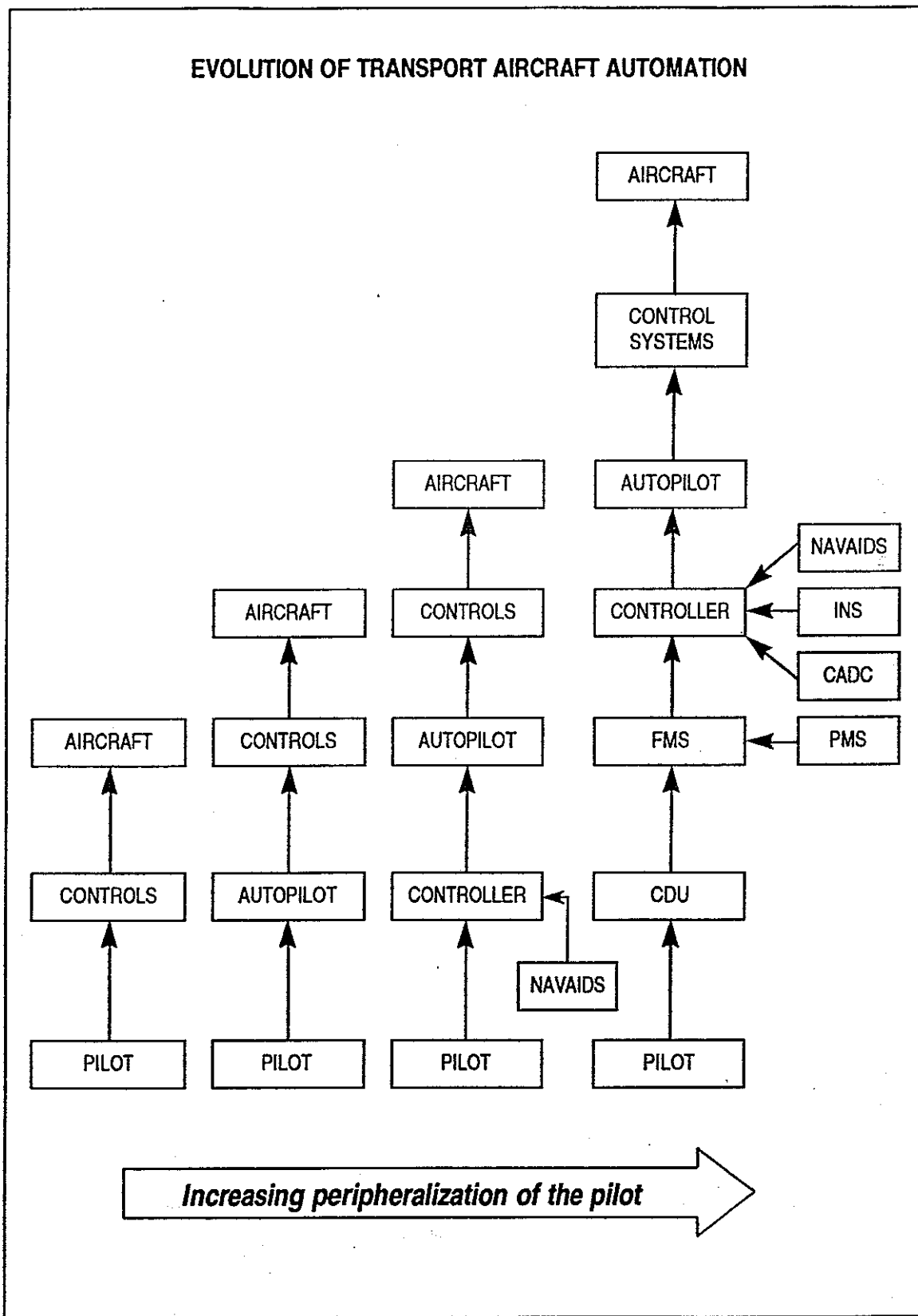

Figure 3-1

### Boeing Flight Deck Design Committee

#### Examples of accident data reviewed

- Subsystem management accidents — world-wide air carriers 1968-1980

*Accident-related cause*

- Crew omitted pitot heat
- Wrong position of standby power switch
- Flight engineer and captain conducted unauthorized troubleshooting
- Electrical power switching not co-ordinated with pilots
- Flight engineer shut off ground proximity
- Faulty fuel management
- No leading edge flaps on take-off
- Confusion over correct spoiler switch position
- Crewman did not follow pilot's instruction
- Mismanaged cabin pressure

*Design*

- Auto on with engine start
- Automated standby and essential power
- Simplified systems delete maintenance functions
- Auto switching and load shedding — no crew action required
- Shut off on forward panel in full view of both pilots
- Auto fuel management with alert for low fuel, wrong configuration and imbalance
- Improved take-off warning with digital computer
- Dual electric spoiler control
- Full-time caution and warning system
- Dual auto system with auto switchover

#### Allocation of 747-200 flight engineer's duties to 747-400 flight crew

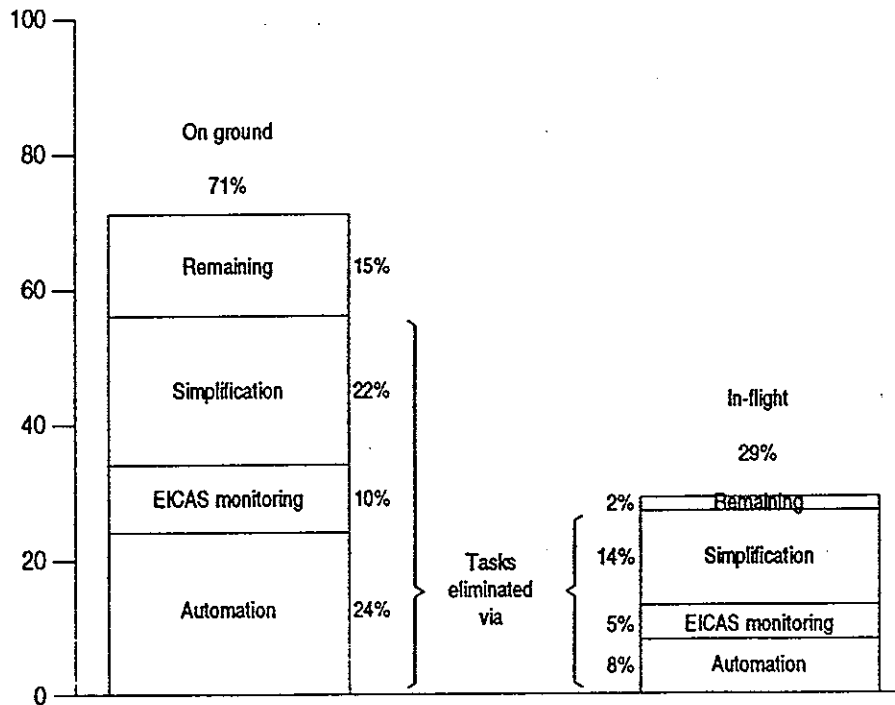

Figure 3-2



forms of error. Questions have arisen about the complexity of control and display units (CDU), and elimination of the CDU keyboard data entry has been considered, although it might be difficult to find a suitable replacement.

3.2.8 Furthermore, latest generation aircraft include drastic evolutions in the field of information exchange between crew and aircraft. The amount of information exchanged has increased considerably: for example, more than 200 checklist items can be displayed on the Electronic Centralized Aircraft Monitor (ECAM) CRT of an A320. At the same time, crew/aircraft interfaces have been highly concentrated and integrated, with the same interface unit now shared by crew and aircraft to exchange immense quantities of very diverse information. CRT displays in electronic flight instrument systems (EFIS) technology have allowed multiple source information to be combined and displayed in a highly synthesized form, presenting four basic pictures of aircraft status: primary flight path control; navigation; engines and flight controls monitoring; and systems monitoring. The conventional control wheels, throttles, knobs and buttons have been replaced as the primary means of information transfer between aircraft and crew. Their function has been assumed by a flight control unit for short-term, real-time (tactical) instructions and a control display unit for long-term (strategic) data input.

3.2.9 Although this last step in flight deck evolution does not fall within the scope of the definition of automation presented in 3.2, it is associated with the issues discussed in this chapter. Indeed, it is often difficult — and rather artificial — to separate automated processes from their related processes of information exchange. Furthermore, advanced or “glass cockpit” technology tends to generate Human Factors-related problems similar to those encountered in automation (over-reliance, human displacement, etc.).

3.2.10 Some mention of the reasons behind flight deck automation has already been made in the preceding paragraphs, and the subject can be expanded as follows:

- *The availability of technology*, mainly through the explosive growth of microprocessor technology. The increased speed and capabilities of jet aircraft, the growth in air traffic, the costs of an accident (in terms of human life and liability), and the recognition of human limitations are some of the reasons for which machine assistance was sought. It is worth noting that while some of the promises of automation were soon realized, many of its problems have only recently been recognized.

- *A continued concern for safety*, as a consequence of the persistence of human error in accident and incident reports. The goal was to remove error at its source — to replace human functioning with device functioning (Figure 3-2). However, the devices have to be monitored by humans, and humans are at best poor monitors. The interface between humans and devices has the potential to generate errors which can result in accidents, and in some cases the automated devices have succeeded only in relocating error rather than in eliminating it. The extent to which over-all safety has been improved is thus still debated in many circles.
- *The goal of enhanced economy*, through improved navigation and over-all flight and fuel consumption management. *Reliability and ease of maintenance* can be included under this heading. Generally these have been quite impressive in the new generation aircraft.
- *The attempt to reduce workload and thus crew complement*, allowing the introduction of wide-body aircraft requiring only a two-pilot crew. Automation was seen as one way to reduce flight deck workload, but experience suggests that, while a reduction in manual workload has been achieved, mental workload has not been reduced by the same amount. In fact, it may have been increased. Operational experience also suggests that automation may not always reduce workload in those phases of flight in which it is usually high, for example, arrivals and landings at busy terminals.
- *The goal of economy of cockpit space*, by taking advantage of the flexibility in displays and controls allowed by digital systems. More information can be made available to both the flight crew and ground stations.

3.2.11 One conclusion of relevance is apparent for operational personnel: the implementation of automation has been incremental in nature (or *evolutionary*), rather than following a global or systems level design strategy (*revolutionary*). This means that the development of independent components led to their progressive introduction into the flight decks when they were available, slowly building up to present-day level of automation. When progress in gyroscopic stabilizer technology enabled attitude control, for instance, this piece of automation was introduced into the flight deck, surrounded by non-automated instrumentation and controls. When control and fuel management through systems

became possible, performance data computers/control systems were retrofitted to electro-mechanical flight decks. When development of ground-based systems enabled it, automated navigational control (e.g. the autoland system) was duly introduced; finally, when microprocessor and CRT technology allowed it, "glass cockpits" were introduced. Presently, efforts are being directed to the integration process discussed in 3.2.8 (Figure 3-3).

3.2.12 In academic terms the above is known as a *technology-centred approach*, as opposed to a *human-centred approach*. In a human-centred design the human is the central element in control and management of the system, and automation is present to assist the crew. To a considerable extent, the value of automation is the degree to which it just does that. This difference between the human-centred and the technology-centred approaches has relevance, because there is no co-ordinated philosophy of flight deck automation. Experience suggests that many problems associated with the introduction of advanced technology onto the flight deck of commercial aircraft arise from the lack of a consistent, co-ordinated philosophy (Figure 3-4). Such a philosophy would consist of device-independent guidelines, so that each new device, operating technique, doctrine or training programme can be held against a "template", rather than designed, implemented and defended anew.

3.2.13 Particular operational issues associated with the introduction of automation will be discussed in some detail in 3.3. When considering the advantages and disadvantages of the evolutionary nature of the introduction of automation as compared with a hypothetical revolutionary introduction, it can be argued that changes in the task of piloting an aircraft have been of an evolutionary nature throughout the history of commercial aviation. The problems emerging from automation could then be dealt with by the traditional training and operational resources, adapted to cope with this particular demand. (This subject will be discussed extensively in 3.4.) On the negative side, one of the assumptions behind a technology-centred approach is that automation will reduce or eliminate certain skill requirements. This is not always the case, and experience indicates that because of the change in the human role, what takes place is a change in rather than a reduction of the skills required. These skills are frequently more demanding: for example, more diagnostic and fault-finding tasks have appeared, and more alternative selection is required. A further possibility is that the skills required by universal automation are simply additional skills.

3.2.14 There is an established tendency to compare the human and machine, in terms of the functions for which the human is superior to the machine versus the

functions for which the machine is superior to the human. The proponents of this comparison argue that in order to plan, design and operate complex systems, human and machine functions should be described using the same set of parameters. This means describing human functions in mathematical terms comparable to the terms used in describing mechanical functions. The fallacy in this contention is that any time human functions can be reduced to a mathematical formula, a machine can be built which can perform the functions better than the human.

3.2.15 This chapter does not endorse any comparisons, and supports the notion that human and machines are not *comparable* but are *complementary*. Rather than compare the abilities of humans and machines to accomplish a task, one must think about how the human and the machine can complement each other to accomplish the task. Automation should function to *supplement*, not to *supplant*, the human management and control function in civil air transport.

### 3.3 ISSUES AND CONCERNS IN AUTOMATION

3.3.1 There is enough information, both from safety deficiencies information systems and from accident reports, to illustrate the impact of the technology-centred approach to automation. In 1985, the Society of Automotive Engineers (SAE) Human Behavioural Technology Committee (G-10) established a subcommittee to consider flight deck automation. The G-10 comprises pilots, engineers and Human Factors specialists representing airlines, Federal Aviation Administration (FAA), National Aeronautics and Space Administration (NASA), United States Air Force (USAF), Department of Transportation (DOT), National Transportation Safety Board (NTSB) and aircraft manufacturers.

3.3.2 The G-10 subcommittee on automation held several meetings, during the course of which more than 60 concerns relating to automation were identified. These concerns were grouped into nine categories:

- situation awareness
- automation complacency
- automation intimidation
- maintenance of the captain's command authority
- design of the crew interface
- pilot selection
- training and procedures
- the role of the pilot in automated aircraft
- other issues

<b>MD-11 Cockpit Automation</b>	
<i>TYPICAL AIRCRAFT SYSTEM</i>	<i>MD-11 SYSTEM</i>
<ul style="list-style-type: none"> <li>• Autopilot</li> <li>• Flight director</li> <li>• Auto throttle</li> <li>• Compass system (slaved)</li> <li>• Auto nav — lateral</li> <li>• Auto nav — vertical</li> <li>• Performance (auto speed)</li> <li>• Attitude director indicator</li> <li>• Horizontal situation indicator</li> <li>• Engine instruments</li> <li>• Aircraft alerts</li> <li>• Fuel system</li> <li>• Hydraulic system</li> <li>• Environmental system</li> <li>• Electrical system</li> </ul>	<ul style="list-style-type: none"> <li>• Auto flight system</li> <li>• Flight management system</li> <li>• Electronic flight instrument system</li> <li>• Aircraft system controllers</li> </ul>

Figure 3-3

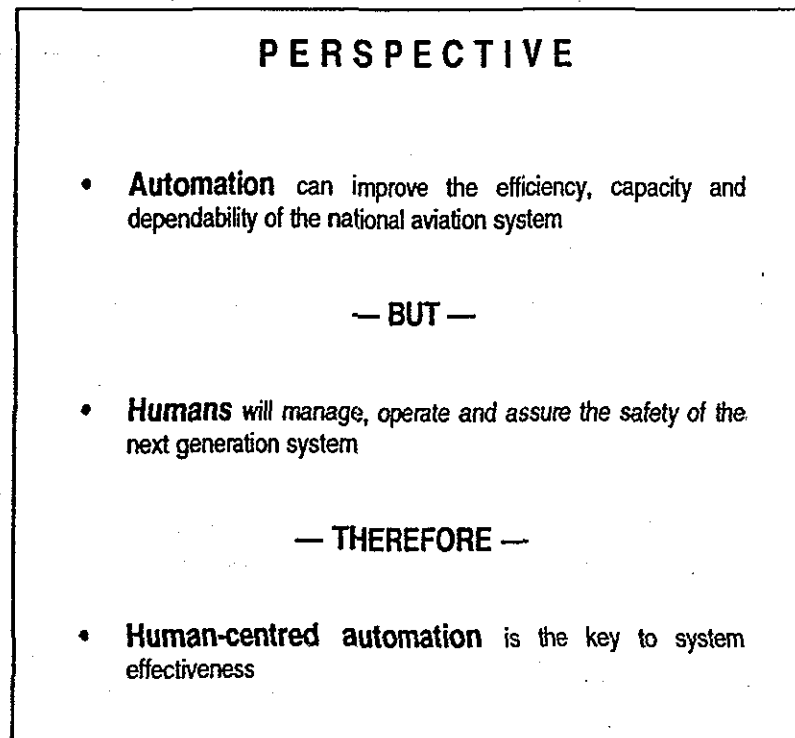

Figure 3-4

3.3.3 What follows is a further elaboration of this basic list, with special emphasis on those issues which are relevant to operational personnel. An exception is made with the item "training and procedures", which will be dealt with in detail in 3.4.

- **Loss of situational awareness** occurs when a pilot develops, and fails to recognize, a lack of perception or an erroneous perception of the state of the aircraft and its relationship to the world. Shortly after the introduction of commercial jet transports, a Boeing B-707 flying at 35 000 feet over Newfoundland experienced an autopilot disconnect and began a downward spiral. The crew did not detect the uncoupling of the autopilot until well after an initial loss of control had taken place. The crew recovered the aircraft at about 6 000 feet above the Atlantic. About 15 years later, the crew of a Lockheed L-1011 was attempting to diagnose a landing gear unsafe warning light, when an autopilot disconnect occurred — probably because one of the crewmembers bumped the control column — and the aircraft slowly descended from 2 000 feet to crash into a swamp area. The crew was never aware of what was actually happening until it was too late.
- **Loss of systems awareness** occurs when a pilot is unaware of the basic capabilities and limitations of automated systems, or develops erroneous ideas of how systems perform in particular situations. In 1985, a Boeing B-747 flying at 41 000 feet over the Pacific suffered a partial loss of power in its number 4 engine. The crew took no action, and when the authority of the autopilot to correct the yaw was exceeded, the aircraft first rolled, almost inverted, to the right, then the nose fell through the horizon into an almost vertical dive. The aircraft was recovered at 9 500 feet. The crew initially believed that the unusual attitude shown in their instruments was due to instrument failure. It might be worth noting that the aircraft stayed at an altitude it was unable to maintain on three engines for approximately two and a half minutes before it went out of control. The following report from the Aviation Safety Reporting System (ASRS) data bank also illustrates this kind of problem:

*"On take-off roll in Newark, the autothrottles were armed and take-off power was set. Departure control told us to level off at 4 000 feet, which I did. I expected the autothrottles to reduce the power upon level off. They did not. I retarded them manually but they once again advanced to climb power. While fighting a battle with the throttles,*

*ATC told me to turn to a heading of 230 degrees and intercept the 335 radial of Colts Neck VOR, which I did. At this time I disconnected the autothrottles by means of a button on the side of the throttles. This action caused a bright red light on the instrument panel to begin flashing. It is necessary to push the light to extinguish it. While trying to push the light, I accidentally and unknowingly pushed the light adjacent to the flashing red one. This was the Omega Nav system engage switch and it immediately caused the VOR needle to centre. When I saw the needle centred, I made a left turn to intercept what I thought to be the radial 335 of Colts Neck. Shortly thereafter, departure control questioned this action, informed me that I was in LaGuardia's airspace ..."*

- **Poor interface design**, which results from the system having the capability to adapt to a change in the operational condition (i.e. a change in assigned landing runway), with such a complicated and time-consuming human-machine interface that the system's usefulness is limited when it could be most effective. Poor interface design may combine with the time required for the human to take over from automation (takeover transient) and may become an important factor, by reducing the quality of execution or practice of an event due to lack of warmup. If combined with a lack of situational awareness to create an unsafe condition. Humans normally require the establishment of an appropriate mental set and proper neuromuscular condition to perform at peak effectiveness. The relative inactivity induced by automation reduces human readiness and initial skilled performance. Consider the following ASRS report:

*"The autothrottle did not respond (it was armed) to speed decrease when set to IAS/Mach mode. The aircraft levelled off in ALT HOLD mode, but the throttles did not advance, and the airspeed decayed in the length of time that it took me to try and get into VERT SPEED mode (which did not work). I disconnected the autopilot and at about the same instant the stick shaker activated. I manually advanced the power and hand flew the aircraft back on to the glide slope ..."*

It is interesting to note that it was not necessary to disconnect the autopilot; a manual increase of engine thrust would have been enough.

- **Reversion to manual control** arises from the understandable fear in some pilots of automated aircraft that they will lose basic flying skills. Many

pilots elect to fly their aircraft manually in order to maintain these skills. In other cases, however, there may be a reluctance to take over from automatic systems resulting from the fear of having lost the necessary skills. The adequacy (or inadequacy) of training in new airplanes, and of procedures and company philosophy, have an impact in this item. It will be further discussed in 3.4.

- **Automation-induced crew co-ordination changes** have occurred because many of the functions previously performed by the crew (observable human behaviour), have been transferred to the computers (hidden, and hard to observe, machine behaviour). A case for the need for improved crew communication can thus easily be sustained. This subject will be expanded in 3.4 under CRM and LOFT training. The following report from the ASRS illustrates the point where programming a system took precedence over basic navigation and position awareness:

*"Using Flight Management System navigation direct to DQO, we were cleared to turn left 15 degrees and enter a hold west of PAILS on J42 ... while finding PAILS on the chart and writing the hold into the Flight Management Computer the hold was overrun ..."*

- **Attitudes towards automation** expressed by some pilots indicate a frustration over the operation of automated systems in a non user-friendly environment, although improvements in the human-machine interface would probably reduce this feeling to some extent. This frustration might be best summarized by a question put by pilots: "who is in command, the aircraft or me?" Automation has not been uncritically accepted by the crews, nor should it be. Some aspects of automation are accepted while others are rejected; in some cases because pilots did not operate the equipment acceptably in the real world environment. This was especially true, for example, in some early versions of autothrottles. Some pilots have accepted automation as a whole while others have rejected it. Generally pilots state that they enjoy flying modern aircraft, but still express a concern for safety, because of the opportunities for error introduced by automation. The ASRS example provided under the heading "loss of system awareness" above is also applicable here.
- **Motivation and job satisfaction** involves problem areas such as loss of the pilot's feeling of

importance, the perceived loss in the value of professional skills, and the absence of feedback about personal performance. Much has been said about the changing role of the pilot; however, many believe that the basic task of flying passengers and freight safely from A to B remains unchanged, and that automation simply represents additional tools to assist in achieving the task. It should be clear that this issue cannot be solved by using only a series of operational orders or bulletins.

- **Over-reliance on automation** occurs because it is easy to become accustomed to the new automated systems' usefulness and quality — when things go wrong, there may be a reluctance by the crew to disconnect automation (some contend that there is also an element of complacency here). There is also a tendency to use automation to cope with rapidly changing circumstances, even if there is not enough time to enter new data into the computer. In 1984, a DC-10 overran the runway at New York JFK and came to rest in the mud. The aircraft landed long and fast (touched down at the 4 700 foot point of the 8 000 foot runway) following an automatic approach during which the crew allowed the autothrottle system to maintain a speed 40 knots above the approach reference speed. There were valid airspeed indicators within inches of the limited fast-slow indicator that was being monitored. Overreliance was also identified as a factor in the case of the B-747 high-altitude upset previously described. As another example, a DC-10 stalled while climbing to cruise altitude, in 1979. In this case, the autopilot had been programmed for vertical speed rather than in airspeed mode. Maintaining constant rate of climb, airspeed diminished until engine thrust became insufficient to maintain flying speed, and the airplane entered stall buffet. This was misidentified as vibration in No. 3 engine, which was subsequently shut down. The airplane then stalled, rolled to its right, and lost 11 000 feet before the crew recovered. Consider also the following pilot report from the 1989 Wiener study:

*"Captain flying late at night, FL 410 on top of severe weather. EPR malfunction on right engine caused autothrottle to slowly retard throttle. Left engine very slowly went to maximum continuous, but speed dropped off. I noticed speed 20-25 knots below bug speed and advised the captain. Came very close to a stick shaker/stall over a thunderstorm. Need to maintain scan even at cruise."*

- **Systematic decision errors.** Humans may depart from optimal decision practices, particularly under time pressure or other stress. The existence of human biases may further limit the ability of humans to make optimal decisions. One approach to reduce or eliminate biased decision-making tendencies is to use automated decision-making aids at the time decisions are required. In such a system, humans adopt one of two strategies: accept or reject the machine recommendation. The evidence to date suggests that such machine-human decision systems often worsen, rather than improve, decision performance. The inadequate design of procedures may also lead to systematic errors. The crash of the B-737 on take-off from Washington National Airport because of ice buildup on the wings has been used to illustrate a variety of classic human decision-making limitations.

- **Boredom and automation complacency** may occur because some portions of the flight are so completely automated that pilots are lulled into inattention and are either bored or complacent. In the particular case of complacency, humans are likely to become so confident that the automatic systems will work effectively that they become less vigilant and/or excessively tolerant of errors in the execution of the desired performance. Their alertness may at times falter (see Figures 3-5 and 3-6). It is desirable to secure pilot involvement and understanding in all phases of the flight, while still maintaining the efficiency of flight that automation provides. Keeping pilots in the control loop, even just at frequent intervals, is better than requiring them to simply monitor the system's operations over long periods of time. Consider the following pilot report from the 1989 Wiener study:

*"Relying on VNAV (vertical navigation) to bug back the speed at 10 000 feet automatically leads to complacency. When FLCH (flight level change) is used for descent, I have been substantially below 10 000 before realizing that I am still at 300 knots."*

- **Automation intimidation** results in part because of an increase in system components. The result is a reliability problem, since the more components there are, the more likely it will be that any one will fail. However, some pilots remain reluctant to interfere with automated processes, in spite of some evidence of malfunction. This is partly due to inadequate training and partly because of management pressure. The captain's decision to

accept and maintain an excessive airspeed, derived from the autothrottle control system during approach, caused a DC-10 to land about 2 800 feet beyond the displaced threshold of the 9 191-foot, water-contaminated runway at Boston Logan. It overran the departure end of the runway and slid into shallow water. Consider also the following pilot report from the 1989 Wiener study:

*"First Officer was going to land threshold minus 10 knots decreasing, nose up 12 degrees increasing — because it was a practice autoland. We would not only have gotten the tail, but probably would have wiped out. When I told him to take it around he said it was an autoland. I took over and made it from about five feet. An EEC on the right was faulty, which we found out at the gate. The big factor was his attitude that some computer would do it all and he didn't have to observe the [company's recommended] seven degrees nose up and threshold speed [emphasis added]. The autosystem is great, but we pilots are the 'break glass' if all else fails and we must put out the fire ..."*

- **Distrust**, because the assessment of a particular situation by the human differs from the automated system. If the system does not perform in the same manner as a human would do, or in the manner the crew expects, or if the human is not properly trained, it would lead to either inappropriate action or concern on the part of the human. This is aggravated by flaws in system design which lead to nuisance warnings, like those which plagued the first generation of Ground Proximity Warning Systems (GPWS).<sup>3</sup>
- **Pilot selection procedures** will need to be re-examined regarding the relative value of flight experience and flying hours. Some contend that automation will lead to less concern for crew selection. In reality, more attention will have to be devoted to selection procedures because of automation in advanced flight decks. Allocations of functions between human and machine will have to be made, based on the knowledge of the implications underlying these allocations. An important aspect of these implications is the set of prerequisites that the pilot must bring to the job so as to fulfil the defined role. This implies the necessity for a re-evaluation of existing selection criteria, or the development of more advanced and specific criteria, to properly screen and recruit the most suitable candidates for advanced technology flight decks. Careful and systematic approaches

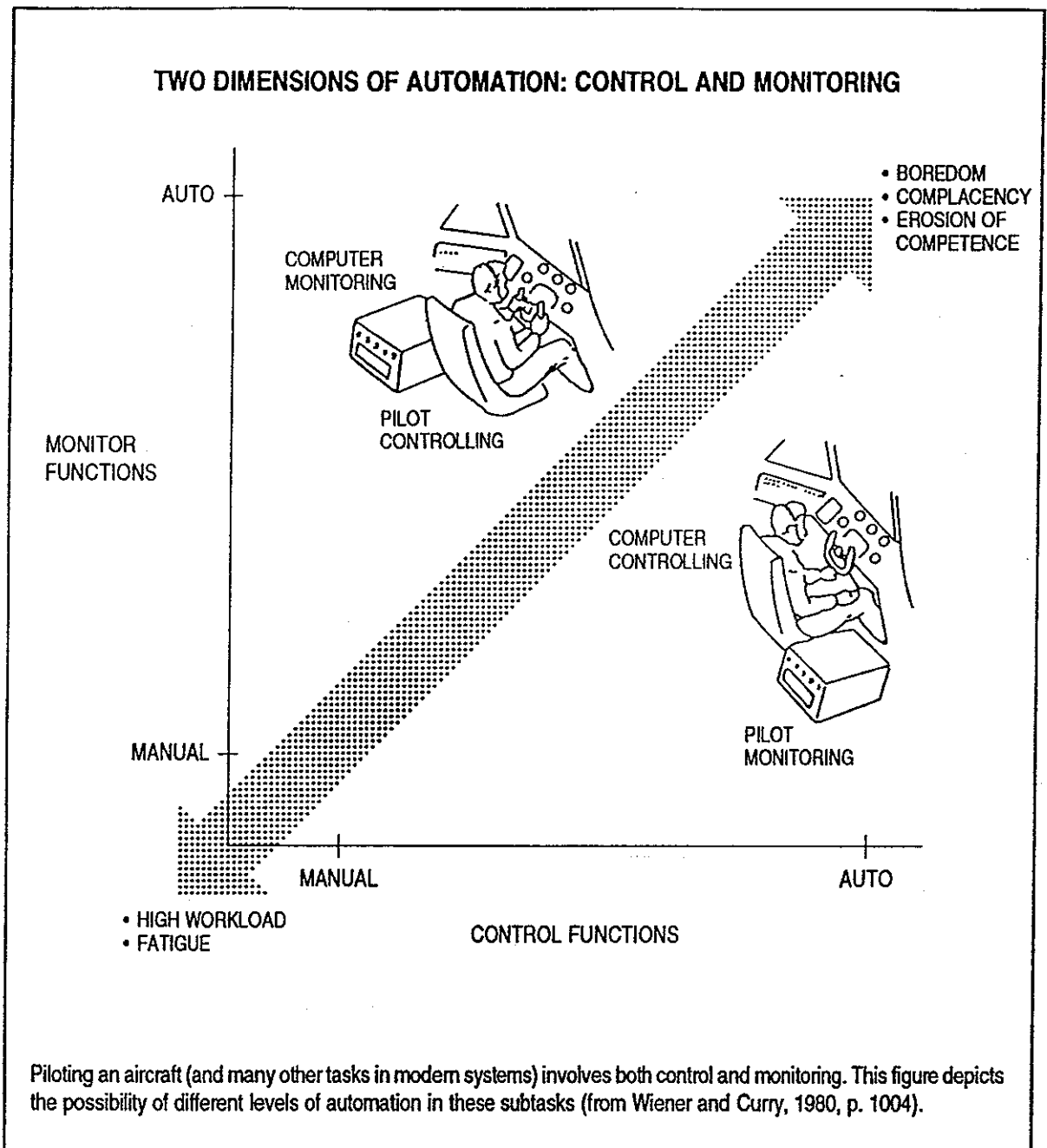

Figure 3-5

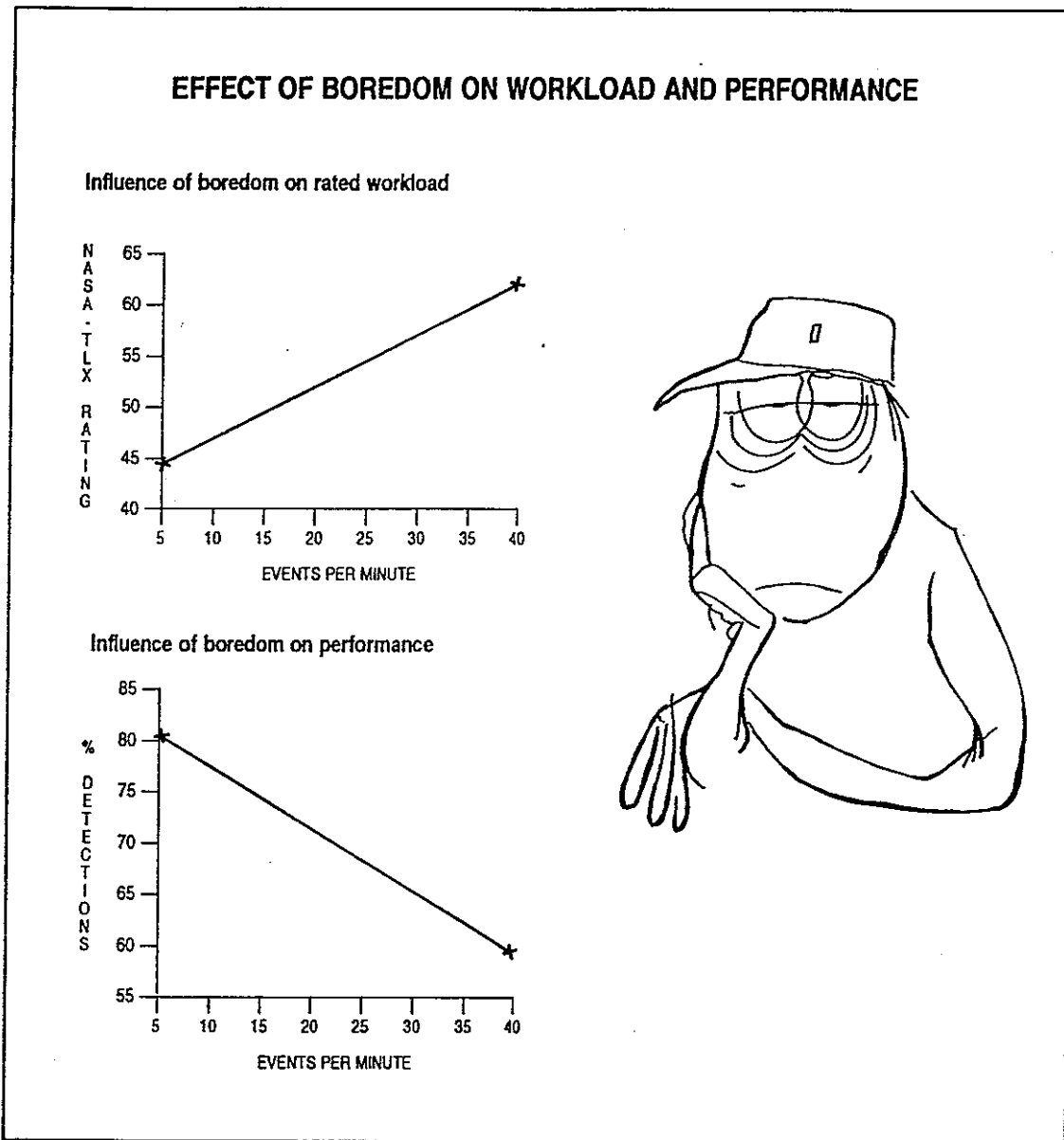

Figure 3-6



using validated selection procedures will translate into reduced flight training and into increased operational safety and efficiency.

- **Mode confusion and mode misapplication** are results of the many possibilities offered by automation, as well as by inadequate training. It is possible with the new computer technology for the crew to assume that the aircraft is operating under a certain control mode when in fact it is not. This can also be a training or procedures problem. Mode status and mode changes must always be clearly annunciated to the crew. The number of modes available should not be too great nor should the difference between modes be too subtle. This report from the ASRS data bank illustrates the point:

*"The aircraft was climbing to FL 410 with the right autopilot and the throttles engaged and controlling the aircraft. At approximately FL 350 the airspeed was observed to be below 180 knots and decaying. The autopilot was disengaged and the pitch attitude was decreased. At this point the stick shaker activated and a small buffet was felt. Application of full power and a decrease in pitch attitude returned the airspeed to normal. Remainder of the flight was uneventful.*

*During the climb portion of the flight I believed the autopilot was in the Flight Level Change Mode (max climb power and climbing while maintaining a selected airspeed/Mach). Looking back now I feel the autopilot must have been in the Vertical Speed mode, and not Flight Level Change. If this were the case with 2 500/3 000 feet per minute up selected, then the airspeed would be near normal to about FL 300 at which point the airspeed would bleed off as the autopilot maintained the vertical speed ..."*

- **Interface with the existing ATC system** is easily done as long as there are no flight plan changes. However, when changes are required — as they are in every flight — the data entry may take more time than the ATC environment allows, particularly at lower altitudes. The controllers need to understand the capabilities of the newer generation of aircraft (as well, pilots need to understand controllers' dilemmas). With modern aircraft, a course change may not be immediate, because the crew first enters new course data into the flight management computer rather than immediately executing the requested course change. There are also differences between

different advanced technology airplanes (A320, MD-11, B-747-400, etc.). System design should permit rapid and easy course changes or direct pilot input for heading, altitude and airspeed changes. The following example, presented by Wiener (*Cockpit Automation Issues in CRM and LOFT Training*, 1989) illustrates this point:

*"After taking off from SJC and completing the first part of the LOUPE FIVE departure, the following clearance was issued: after Wilson Creek, direct 37 degrees 45 minutes north, 111 degrees 05 minutes west, direct Farmington as filed. When the crew attempted to enter this into the system, they found that the sequence of the clearance did not conform with the format required by the system. After considerable frustration, they found the correct format (on another CDU page) and used it as a model. Why ATC felt the need to issue a lat and lon waypoint instead of a bearing and distance of a nearby VOR (which is easy to enter) is not known."*

- **Vulnerability to gross error** due to the fact that automation tunes out small errors and creates opportunities for large ones. A simple example illustrates this point: the digital alarm clock. It can be set very precisely but, unlike the analog alarm clock, it operates on a 24-hour cycle, so a wakeup time can mistakenly be set for p.m. instead of a.m. With the introduction of a digital system, a precise blunder was born: the precise 12-hour error. With increased automation in transport aircraft, most of the gross errors involve improper digital data insertion and monitoring of the FMCS.
- **Workload management**, because workload, especially on the monitoring pilot and particularly at low altitudes in terminal areas, can be very high. Workload may go rapidly from underload to overload, since systems do not necessarily degrade slowly. The advance of automation has been based partly on the assumption that workload would be reduced, but there is evidence to suspect that this goal has yet to be achieved. In effect, data from some of the studies in automation indicate that the pilots' perception is that automation does not reduce workload, since it involves greater monitoring. In the words of one pilot, "... a lot of times we just click it off and go back to manual if the load becomes heavy".
- **Heads-down time** is something that must be studied. It refers to the activities that direct the crew's attention inside the flight deck, like

instrument scanning, computer programming, chart consultation, etc. These activities prevent the crew from looking at the external surrounding environment. There is concern about the amount of such time spent by pilots, particularly when the aircraft is below 10 000 feet in a terminal area. Significant heads-down time (and workload) is associated with runway reassignments, deviations from standard arrivals and standard instrument departures, speed changes, and crossing restrictions. All of these are a normal part of today's environment, and all have training, procedural and automation implications.

- **Suitability of the supervision of training**, which raises — among many others — questions about the selection or deselection of automatic devices as the trainee sees fit during training, or as specified by the examiner during verification. It has been proposed that present regulations are not fully responsive to the technical and operational requirements of contemporary operations, and that a review is needed.

3.3.4 One of the most controversial issues in automated flight decks concerns the role of the pilot. Some argue that the main job of the pilot has changed from being primarily a manipulator of flight controls to a systems manager, while others believe that the basic task of safely flying passengers and freight has remained unchanged, and that all changes have simply been evolutionary. ICAO believes that the latter view is closer to the truth. Today's pilots simply have available additional tools in automation. These new tools clearly represent new challenges.

### 3.4 TRAINING FOR AUTOMATION

3.4.1 Pilot training is very important and it is also very expensive. There is no argument regarding its importance, but there is not always agreement on the kind and amount of training required to enable pilots to operate new and different airplanes safely and efficiently.

3.4.2 The controversy regarding the effect of automation on training is an entirely separate issue. Some claim that automation requires additional skills, while others propose that automation reduces training costs and also reduces the level of traditional flying skills required in older (conventional flight deck) aircraft; in contrast, others propose that one of the greatest misconceptions about automation is that it reduces training requirements. Notwithstanding these conflicting opinions, there is little

doubt about the importance of training. The interface between transport aircraft and the pilots who operate them is of great importance, as are the interfaces between the pilot and the manufacturer, procedures, Standard Operating Procedures and company operating philosophies. The purpose of this section is to identify some issues that have been raised regarding training in advanced flight deck technology aircraft.

3.4.3 One controversial issue already mentioned has been the changing role of the flight crew in automated flight deck aircraft. It comprises at least two basic questions:

- Is the pilot a control operator, a systems manager, or both?
- If a difference exists, is it in the pilot's role, or in the elements of that role?

Analysis suggests that the primary role of the transport pilot has not changed at all: since the *goal* is (as it has always been) to complete the planned flight safely and efficiently and with a maximum of passenger comfort, the *role* is to achieve that goal — to fly safely and efficiently from point A to point B. The *functions* still include monitoring, planning, and making decisions in reference to the operations, and the *tasks* are those traditionally performed (communicating, navigating and operating). The question is how best to train pilots for advanced technology aircraft.

3.4.4 The consensus seems to indicate that, as a general approach, automation should take a greater role in maintaining basic stability and control of the aircraft. Higher-level functions, such as flight planning/pre-planning, system status management and decision-making, should be performed primarily by humans with the help of automation. Training should reflect the increased emphasis on the pilot's decision-making, knowledge of systems, monitoring and crew co-ordination. One point is clear, however: automation has not reduced the need for the basic airmanship skills and knowledge which have always been required of airline pilots. The importance of those fundamentals should be emphasized in the early phases of training, and general aircraft instruction should always precede detailed instruction in automatic features. The training should be sensitive to the varying needs of a pilot population that differs widely in areas such as total flight experience, corporate experience, recency of last transition training, computer literacy, etc.

3.4.5 One of the lessons learned regarding advanced technology aircraft is that *assessment of training requirements* should be made when a new aircraft type is

designed. Determination of the general training requirements needed to enable pilots to operate new equipment safely and efficiently should be considered an integral part of the design process. These requirements need not be — and probably should not be — very detailed. They should clearly indicate what the designer of the system believes the pilot should know in order to operate that system safely and efficiently. The next occasion to do this would be when the new type is introduced. This gives an opportunity to introduce operational changes, but any inefficient practices existing at the time of introduction will tend to endure. This is the time to appreciate and understand the manufacturers' design and operating intents, since they heavily influence training and operational issues. Those responsible for the introduction of new types, or charged with the responsibility of training development, should possess more background information with regard to the basic design philosophy than was needed in the past. This is important since most of the existing training programmes for new technology aircraft were originally developed for conventional aircraft.

3.4.6 Careful considerations should be given to the *adequacy of the transition training programme*. The complexity of many of the systems may require a higher level of initial understanding and operational skill than was required with previous aircraft. The basic question is: do pilots, after completing their transition training, have sufficient skills, knowledge and understanding to operate these aircraft safely and efficiently? Although some believe that the traditional high level of manual skills will be required to a lesser extent, greater demands are placed on intellectual or mental skills due to the complexity of the systems and the environment in which they are operated. There is also evidence that routine operation of automatic modes may not provide adequate training opportunities. Flight deck observations have shown that pilots use only a few of the features available to them, because of incomplete knowledge about how to use other features. This says much about the inadequacy of the training and the complexity of the systems and modes.

3.4.7 *The depth of training* should ensure that pilots thoroughly understand systems interdependencies. This understanding may no longer be intuitively obvious even to highly experienced pilots. Training must provide more specific information about systems than was previously required when systems interdependencies were much less pronounced. The following examples, proposed by Jean-Jacques Speyer, with Airbus Industrie, illustrate this point:

*"The link between A320 nosewheel steering and the Air Data Inertial Reference System (ADIRS) would have been impossible to achieve in previous design*

*generations. Yet, the conceptual advantage — nosewheel steering sensitivity as a function of aircraft speed — is quite straightforward. As with most automation concepts, however, the benefits are often counterbalanced by an increased need for an in-depth operational understanding which may not be intuitive. A pilot experiencing difficulties with nosewheel steering may need to work through the operation of the steering, the ADIRS and their interactions in order to understand and cope with the anomaly. Similarly, the advantage of linking both pressurization computers with both Flight Management and Guidance Computers (FMGCs) and all three ADIRs on the A320 is that planned and actual flight profiles can be continuously compared for adequate pressurization control in any phase of flight. However, the pilot is then placed in the position of having to understand the interactive system functioning in order to exercise the ultimate accountability function."*

Training time devoted to aircraft operation with the automated system(s) failed would increase pilot confidence in taking manual control early and effectively.

3.4.8 It must also be remembered that "surface" competence during the normal operation of a new system may well differ considerably from "real" competence which can withstand high stress and high workload. To withstand such pressures, skills need to be overlearned. This is basic knowledge which does not seem to be always applied in practice. In order to obtain the necessary intensive hands-on training, *the value and applicability of part-task trainers* has been recognized. These devices include a high-fidelity simulation of a particular system (or even the actual piece of equipment) which allows the student to concentrate on it without the extra load and distractions which might be imposed by a full flight simulator. They are less elaborate, and can range from large photographs which emulate the flight deck around the simulated system, to sophisticated desk-top computer-assisted training (CAT) devices. Part-task trainers can be highly cost-effective in developing the skills required for efficient system operation. The major drawback of some of these devices — as presently designed — appears to be a lack of functional realism (e.g. at a given point of any exercise, there may be only one allowed sequence of responses, whereas in the real system much more freedom is available).

3.4.9 *The use of home computers* to fulfill training requirements and for voluntary self-instruction should be explored. There is potential for misuse here, but there is also a considerable potential for fulfilling the needs and desires of pilots, management and authorities. Although implementation may be a particular challenge, experience

indicates that some basic computer literacy (i.e. being comfortable with an alphanumeric keyboard) will make transition to new technology flight decks easier.

3.4.10 *The time elapsed since the last transition training* is an important factor when considering pilots' needs. Flight guidance systems and other automated systems are certainly more complex than in previous aircraft, yet it has been noted that quite often some pilots making the transition to these aircraft had not been to ground school for periods as long as 15 years. This may have contributed to the difficulties of some of these pilots, for whom transition training to new technology may not always go smoothly and may involve higher than expected training costs. *A lack of meaningful operating experience* (which can be quite different than total flight time) should be expected for the period immediately following training. One way to solve this problem may be to expose the flight crews to highly realistic flight situations in high-fidelity simulators. In many countries this is called LOFT (Line-Oriented Flight Training)<sup>4</sup>. Because of the sophisticated equipment, the variety of situations that can be simulated, and the highly technical training methods now available, it enables pilots to gain flight experience (in addition to training) that in some cases may be even better than actual flight.

3.4.11 Specific issues also related to transition training include the *transition from electromechanical instruments to electronic flight instrument systems; training for the loss of all the electronic displays* (the aircraft would be controlled on standby instruments which are essentially the same as those in previous generation aircraft, but the step down in data available is much greater); and the *use of the autopilot, flight management system and mode control panel*. The manner in which these systems allow the flight to be conducted enables the pilot to become detached from the immediate state of the aircraft (position, speed, height, etc.) Crew procedures and training methods must ensure that no automation complacency is fostered by this process, and that the pilot maintains a satisfactory level of situational awareness. The training should be hands-on and line-oriented, and should stress sound practices.

3.4.12 *Guidelines on the use of automation* should be provided. They should indicate to the crew when to use automation, and, more importantly, when *not* to use it. Even when guidelines are available (usually through company policy or standard operating procedures), they reflect preferred practices in the context of particular operational environments. The existence of such guidelines does not necessarily mean that they are universally applicable, nor is the purpose of this chapter to provide them. The objective of this paragraph is only to identify

this issue, and Appendix 3 provides an example of one airline's approach to a philosophy of automation.

3.4.13 In line with the well established practice of programming wind-shear profiles as part of flight simulator training, it might be worthwhile to explore the benefits of *replaying* incidents or accidents where automation has been considered a factor. The flexibility of contemporary simulator-computer systems and the information available from safety reporting systems makes this possible. Similarly, some contend that there is a need to include and review problems and incidents encountered in day-to-day operations.

3.4.14 The need to monitor should be constantly reinforced, both during training and proficiency checking. The vast literature on vigilance shows, however, that *humans are not uniformly effective monitors*, and frequently miss system faults or wrong set-ups. This trait is sometimes aggravated by *operations in a low stimulus environment*, such as that found in long-range, "back-of-the-clock" operations. The possibility of more or different training has been raised as a remedy, although it seems difficult to achieve consistent gains in this way. Some attention has been directed to placing more emphasis on creating the sort of stimuli (displays, procedures, additional meaningful tasks) that enhance the pilot's ability to monitor them. It is also a fact that pilots can do specific kinds of monitoring very well — for example, monitoring pilot flying performance during an approach from outer marker to touchdown. Many believe, however, that the influence of systems design must be investigated as an alternative to alleviate the problem.

3.4.15 *The adequacy of "differences" training* must be considered when a new aircraft is considered "common" with an older aircraft. It is not unusual for some operators to have not only several different flight deck configurations for the same basic airplane model, but also different computers and software. When such a situation is coupled with mergers and fleet integration, the pilots can be exposed to quite different flight deck arrangements in quick succession. Also, *prolonged absence from advanced technology aircraft* may result in a marked diminution of skill. This has been demonstrated to have a greater impact on piloting proficiency than a similar absence from the flight deck of an older technology aircraft. This loss of proficiency is directly related to the operation of the flight guidance system.

3.4.16 *Requalification training*, when a pilot is returning to a less automated aircraft, must be very thorough. A major training consideration should be deprogramming the pilot's expectations: for example, automatic altitude capture and level off, a common feature

of automated flight decks, may not be available on older technology aircraft. Evidence from field studies in automation (see Appendix I) indicates that pilots are also concerned about the degradation in their cognitive (mental) skills due to the ease of navigation and maintenance of *situational awareness using electronic maps*. Management should be aware of the potential hazards of these reassignments.

3.4.17 The need for *standardization and simplification* of all aspects of operation of two-person crew automated aircraft should be given a high priority. Standardization is one of the foundations of safety, and its importance has been accentuated by the appearance of aircraft leasing organizations, airline mergers, consolidations, etc. Flight crews may be faced with different names for the same item, different procedures to operate the same systems, different symbology to display the same information, and all of this often under demanding conditions. Such problems may also be due in part to the constant improvements in aircraft, their systems and flight deck symbology. Standardization of symbology is receiving considerable and well deserved attention these days. Symbols should be intuitive and their meanings consistent from one system design to the next. Standardization should be emphasized, and this emphasis should be extended to flight operations and equipment manuals, operating procedures and checklists.

3.4.18 *Operational procedures and checklists* should be carefully examined with particular attention to the workload required to perform them. In their operation of two-person crew aircraft, many operators have not reflected the advances that have been made in flight deck technology and in the understanding of flight crew behaviour. Special training considerations should be given to flight crew members making the transition to automated two-person crew airplanes from a three-person crew airplane. The use of *Line-Oriented Flight Training* as a tool to demonstrate heavy workload conditions is proposed in the following paragraphs. More importantly, LOFT can be an ideal tool to identify workloads which are a product of inappropriate policies or procedures, as considerable flight crew workload can be created by having to perform non-operational tasks at inappropriate times (calls for passenger connections, meal requirements, wheel chairs, etc.). This is not a new problem, but it is more critical in the automated environment and with the proliferation of high density operations. (Some aspects of this problem are being met on many of the new airplanes with separate communication facilities for the cabin crew.)

3.4.19 It has previously been assumed that *Crew Resource Management (CRM) training programmes* are model-independent. However, there is abundant evidence

that some aspects of crew co-ordination and communication in the automated flight decks are *qualitatively different from the flight decks of older aircraft*. Recent experiments suggest, for instance, that there is a trend towards less verbal inter-pilot communication as the degree of flight deck automation increases. Customized modules of CRM training programmes should be developed to deal with such differences. These customized modules should also take account of the nature and the needs (culture) of the organization. The following areas of concern in CRM of automated aircraft are the result of observations during actual flights. They indicate that highly automated flight decks may require special scrutiny in the areas of crew co-ordination and resource management, both in the assignment of tasks and the standardization of their performance.

- *Compared to traditional models, it is now physically difficult for one pilot to see what the other is doing.* For example, in previous generation aircraft the autopilot mode control panel was easily observable by both pilots; in automated flight decks the selections are made in the control display unit (CDU), which is not visible to the other crewmember unless the same CDU page is selected. Proper procedures and intra-cockpit communication appear to be the answers to this problem.
- *It is more difficult for the captain to monitor the work of the first officer, and vice-versa.* New or revised procedures and intra-cockpit communication are again the apparent answer.
- *Automation can induce a breakdown in the traditional roles of the controlling pilot and monitoring pilot, and there is a less clear demarcation of who does what.* This is particularly relevant, since it has already been mentioned that standardization is one of the foundations of safety. The answer to this problem might be found in procedures and standard operating procedures (refer also to 3.5.9).
- *Automated flight decks can produce a redistribution of authority from the captain to the first officer.* This is unintended, and is a product of an apparently greater proficiency of some first officers in CDU data entry compared to that of the captains, plus the delegation of these duties to the first officer. Particularly in times of high workload, the captain may surrender some responsibility to the first officer in order to accomplish the task. A somewhat shallower trans-authority gradient<sup>5</sup> may

be the result, although captains, recognizing the superior CDU skills of their first officers, may follow good CRM principles and use them to their advantage.

- *There is a tendency of the crew to help each other with programming duties when workload increases, which can dissolve a clear demarcation of duties. This seems to be computer-induced behaviour, since no similar situation is observed in traditional aircraft.*

3.4.20 Some particular issues about *the implications of automation for the design and conduct of Line-Oriented Flight Training* can be highlighted. The automated flight deck offers new opportunities for scenario design. In conventional flight decks it was necessary to introduce system failures to elevate the workload and stress of the crew in a realistic manner, but the automated flight deck has enough built-in stressors to do this job, especially in the area of ATC instructions. The "glass cockpit" presents new opportunities for scenario design that do not require abnormal conditions or emergencies — difficult problems at the human-automation interface will suffice. There now exists the opportunity to design scenarios that will address the problems and opportunities of working in automated flight decks, where their peculiar characteristics can be stressed and where CRM principles can be easily exercised. For example, an ATC instruction including an unexpected, non-depicted holding pattern over a fix defined by a radial/DME value, provides considerable opportunities to practice CRM principles without the necessity of introducing any system failure.

3.4.21 *Aircraft manufacturers are giving more importance to human performance issues in automated flight decks.* Human Factors knowledge is being increasingly incorporated, in a proactive fashion, during the design stage of flight decks, thus observing a human-centred approach to flight deck design. There are endeavours to integrate CRM training programmes into the transition training courses for new aircraft. Manufacturers' instructor pilots receive CRM training. Training courses for maintenance technicians also incorporate CRM programmes. One particular manufacturer claims that CRM courses to be developed will be airplane-tailored, with a different CRM course for each specific model of aircraft in the production line. The justification for this decision is based on the need to align training with longer-term behavioural education, as well as to concentrate on the assigned duties and responsibilities of the flight crews. Most importantly, it is the tacit recognition that Human Factors education is no longer an exclusive responsibility of the operators, but an integral part of present-day system operations.

3.4.22 *Adequate instructor/check pilot training is necessary*, and must be emphasized, since some instructors may have only a little more meaningful (i.e. operational) experience and knowledge than the students. A strong case can be made for practical experience input to instructor and student training. The need for more emphasis on behavioural issues (CRM and LOFT training) has also been suggested. Though the Human Factors profession has recognized the problem, the issue of instructor training in relation to automation has not yet been properly addressed, and training specialists have only a few sources to consult for guidance on the question of training for automation. Instructor selection and training continues to be determined by the same time-honoured methods and criteria applied for conventional flight decks, although the training issues are quite different on automated flight decks.

3.4.23 *The role of the regulatory authority in the development of training programmes and instructor training must not be overlooked.* During the certification process, the regulatory authority evaluates information presented by the manufacturer. These certification data must be delivered to the operator, since it provides the foundation upon which to build the training programmes. By knowing, for example, the manufacturer's design intent, the operator can develop procedures in which tasks can be properly identified. The training programmes thus defined must then be validated based on the same sources of information, closing the manufacturer-regulatory authority-operator loop. Training should be part of the integral system design, and it must be contemplated as part of a systems engineering approach. Furthermore, regulatory authorities might foster the inclusion of Human Factors knowledge into the design of flight decks by requiring and evaluating Human Factors-related requirements as normal components of the certification process.

### 3.5 MANAGEMENT TECHNIQUES AND COPING STRATEGIES

3.5.1 It has been proposed that every accident, no matter how minor, results from a failure of the organization. The implication of this proposition in operational management is clear. Despite this, management's role has often been overlooked. In automation-related issues, *management impact is vital.* This is because we are still in the implementation phase, and going through the "shakedown" period which always accompanies change. Many decisions have yet to be made — and others have to be modified — related to equipment design, configuration and selection, establishment of

proper procedures and policies, and training strategies. At the systems level, the benefits of management involvement will surpass those which might be obtained addressing operational personnel.

3.5.2 A basic requirement for flight operations management is *to develop an unambiguous understanding of the way flight operations are to be conducted*, for example, by fully explaining the degree to which the crew is expected to use the automated equipment available in the flight deck. This understanding must be stated clearly and unequivocally, and these intentions must then be communicated effectively to flight crews. Equally important, training/check pilots, supervisory pilots, and higher levels of flight operations management should follow the rules and procedures which have been adopted. This should foster a proper management climate and indicate the necessary commitment, which can be further enhanced by proper pilot selection procedures and adequate training packages.

3.5.3 *Management support is also essential in the production and use of operational media.* Flight manuals, aircraft operations manuals, checklists, equipment manuals, operational bulletins and — in automated flight decks — software are all important means of communication that reflect a particular operating philosophy. However, it takes more than simply issuing manuals or directives to communicate effectively with pilots. A permanent contact with the pilots, with a maximum exchange of information, views and policies, is essential, and procedures, equipment and rules should be discussed and justified. Pilots can then understand the reasons for the selection of equipment or procedures, and interest and involvement in their consistent use can be expected. The importance of pilots' involvement in the decision and on design of procedural guidelines also relates to motivation, self-satisfaction, etc.

3.5.4 *Operational management and pilots must be involved in the acquisition of equipment (hardware).* Advanced technology aircraft incorporate changes which represent considerable achievements; they have also created considerable controversy. The cost of any design flaw which is not corrected at the stage of design or acquisition will be paid for, many times over, throughout the entire operational life of the equipment, be it a display, a computer, its hardware or software. Sensible, properly designed training and procedures which cannot be properly implemented because of design mismatches lead to more problems than they solve. At the same time, there is no consensus on how much adjustment to less-than-optimum design can reasonably be expected of professional pilots.

3.5.5 It is hardly surprising that *training and procedures* were highlighted as problem areas in early

surveys of the operation of advanced technology aircraft. In the same way as it was recognized that improper design hinders the implementation of proper training and procedures, it must also be recognized that even the best designed system will not be operated optimally if the training and procedures that accompany it are inefficient. *The establishment of a feedback loop* between operational personnel and the training department is essential, since training precedes and affects flight operations. In regard to automation, there is some evidence that flight crews might not be receiving the amount of training, or the amount of information in manuals and other sources, that they need to understand the systems that they are expected to operate.

3.5.6 *Differences in training for two- and three-person crew operations.* It may be important to give pilots in two-person crew operations more systems training in their initial and periodic training than was given for predecessor aircraft with three-person crews. The change from three- to two-person flight crews results in a significant change, requiring a different approach to flight deck resource management, in standard operating procedures and in checklists. For example, pilots transitioning from the older models B-747 or DC-10 to the newer MD-11 or B-747-400 not only need to master new navigation and autoflight techniques, but also need to learn the command and communication relationships of a two-person rather than three-person flight deck. This might be especially difficult for those pilots who transition to modern aircraft late in their careers; it might also be difficult for operational management which has not recognized these problems. This was expressed by one pilot who reported to the ASRS:

*"We have traditionally been a 3-man airline and we are still using 3-man procedures with a 2-man crew. The problems are in our procedures and checklists, not in the airplanes ..."*

3.5.7 *Pilot promotion policies and scheduling practices* create additional problems. Promotion policies are usually based on collective bargaining agreements and on seniority considerations, and a pilot who has been flying as co-pilot in automated flight deck airplanes might go back to an older jet in order to be promoted to captain. In such a case, it is recommended that additional "back to basics" refresher training be provided. As another example, certain operators' practices include scheduling flight crews in the DC-9 series and the MD-80 series at the same time, based on commonality of ratings, since some authorities have ruled that some of these derivatives are essentially the same airplane and can be operated with a common type rating. This practice needs to be carefully monitored by pilots, operators and authorities, and

eventually re-examined and changed. Automated flight deck and conventional airplanes may need to be given a separate status and the fleets isolated for scheduling purposes. Separation of the fleets, which might be regarded as an economic burden for the operators, is a definite plus for safety, and hence a long-term economic gain.

**3.5.8 Controlling pilot and monitoring pilot duties must be clearly delineated and tasks properly allocated,** with particular emphasis on the role of the monitoring pilot. For the monitoring pilot case, a significant operational anomaly is normally preceded by a preventive monitoring failure; from a systems safety standpoint, this monitoring failure is as critical as the failure of the controlling pilot. Existing data base evidence suggests that risk increases when the captain is performing monitoring duties, since a number of accidents/incidents have occurred when the co-pilot is flying. The problem in part is the ambiguous role played by the captain while monitoring. The argument on this issue goes beyond, but is certainly included in automation.

**3.5.9** In order to relieve boredom and maintain a proper level of vigilance and monitoring during periods of low activity, some have proposed the inclusion of meaningful extra work during these periods (see 3.4). Recently, consideration has been given to the concept of *embedded training* as one of the several ways to achieve this objective; it involves the use of the on-board computers to provide training. It must be clearly stated that the subject of this paragraph is not vigilance, but the ways to use inactive time. As a word of caution, very little guidance is available on resolving the conflict between the maintenance of effective situational awareness and the achievement of valid "embedded training".

**3.5.10** In many parts of the world, *the development of ATC* has not kept pace with advances in flight deck capability. The present ATC system, which is a compromise, is not cordial to the advanced capabilities of new aircraft, since it is essentially designed to accommodate jet transports of the generation of DC-8/9, B-737-100/200, B-727 and similar airplanes. Conversely, the latest jet transports are too sophisticated to operate easily and effectively in today's ATC environment, and the crews cannot exploit their advanced features. The flight guidance and display systems of modern airplanes are impressive: vertical navigation (VNAV) and lateral navigation (LNAV) capabilities, advanced autothrottles, inertial reference system (IRS) navigation, and IRS navigational displays have become familiar equipment. They are ideal for operations in complex environments, but in trying to conform with ATC instructions, they

present problems to the flight crews. To some extent, the lack of controller familiarity with the capabilities of new aircraft is considered an issue, as is the lack of pilot familiarity with ATC problems. Experience has demonstrated that ATC service does improve, however, as controllers become familiar with the new generation aircraft. Familiarization trips on these aircraft present ATC personnel with the opportunity to understand the capabilities of the modern flight decks.

**3.5.11** Mention has been made of *a company environment which provides documentary support to flight crews* (flight plans, weight and balance computations, weather, etc.), and which establishes a feedback loop between operational (flight planning, operations centre, etc.) and training (while this is not model-independent, it is more critical in automated flight decks). The importance of feedback can be best illustrated with the following example, presented by Wiener.

*"The flight crew of a B-757 received a flight plan in which a waypoint was written simply as "CLB" (Carolina Beach), making it appear to be a VOR. When the pilots typed it on the Route page, they continued to obtain "not in database" error messages. The problem was that Carolina Beach is a non-directional beacon (NDB), and to be consistent with the Flight Management Computer (FMC), the flight plan should have listed it as "CLBNB".*

An established feedback loop will allow operators to re-examine their checklists, procedures and all documentation to make certain that they are appropriate for modern flight decks and their particular operations.

**3.5.12** It has been suggested in 3.4 that considerable crew workload can be created by *the requirement to perform non-operational tasks* at inopportune times (for example, calling ahead for passenger connections, meal requirements, wheelchairs and other passenger service items). While this is not a new item, it has become more critical due to the increased workload of two-pilot aircraft in congested, high-density operations in terminal areas. While training solutions might include guidelines to establish priorities and reduce workload, management should establish policies which reassign or eliminate of these tasks. These policies should address the cockpit/cabin crew interface, making it very clear that there are issues in this relationship which are relevant to the two-person crew, and which were not present in three-person crew flight decks. Some managements have recognized this problem, and require separate radio communication facilities for the cabin crew for non-operational communications.



3.5.13 *The establishment of an international reference system*, for collecting and disseminating information on items like selection of the optimum level of automation and other operational procedures, is desirable. This system would refer to existing accident and incident reporting systems. There is considerable evidence that some of the problems associated with automation may well be the product of these differences in training and in procedures. Furthermore, it is a matter of public record that lack of exchange of operational experiences, including automation-induced incidents, has played a role in at least one major advanced technology accident.

#### LIST OF REFERENCES

- Adler, P. (1984). "New Technologies, New Skills". Working Paper, Harvard Business School.
- "Automation in Combat Aircraft". Air Force Studies Board, National Research Council. National Academy Press: Washington, D.C., 1982.
- Amalberti, R. "New-machine Interfaces: A Challenge for Aerospace Medicine". Paper presented at Paris Air Show, Le Bourget, 1989.
- Bailey, R.W. *Human Performance Engineering: A Guide for System Designers*. Prentice-Hall: Englewood Cliffs, N.J., 1982.
- Bergeron, H.P. "Single Pilot IFR Autopilot Complexity/benefit Tradeoff Study". *Journal of Aircraft*, No. 18 (1981), pp. 705-706.
- Boehm-Davis, D.A., Curry, R.E., Wiener, E.L. and Harrison, R.L. "Human Factors of Flight-deck Automation: Report on a NASA-Industry Workshop". *Ergonomics*, No. 26 (1983), pp. 953-961.
- Braune, Rolf J. "The Common/Same Type Rating: Human Factors and Other Issues". SAE Technical Paper Series 892229, Boeing Commercial Airplanes, Seattle, WA.
- Caesar, H. "Design Philosophies of New-technology Aircraft and Consequences for the Users". Germany.
- Chambers, A.B., and Nagel, D.C. "Pilots of the Future: Human or Computer?". *Communications of the ACM*, No. 28 (1985), pp. 1187-1199.
- Costley, J., Johnson, D., and Lawson, D. "A Comparison of Cockpit Communication B-737 - B-757". Proceedings of the Fifth International Symposium on Aviation Psychology, Ohio State University, Columbus, Ohio, 1989.
- Curry, R.E. "The Introduction of New Cockpit Technology: A Human Factors Study". NASA Technical Memorandum 86659, 1985. NASA-Ames Research Center, Moffett Field, CA.
- Degani, A., Wiener, E.L. "Human Factors of Flight Deck Checklists: The Normal Checklists". NASA Contract Report No. 177549. NASA-Ames Research Center, Moffett Field, CA.
- Edwards, E., and Lees, F.P. *The Human Operator in Process Control*. Taylor and Francis: London, 1974.
- Edwards, E. "Automation in Civil Transport Aircraft". *Applied Ergonomics*, No. 8 (1977), pp. 194-198.
- Fadden, D.M. and Weener, E.F. "Selecting Effective Automation". Paper presented at Air Line Pilots Association Safety Workshop, Washington, D.C., 1984.
- Federal Aviation Administration. Report on the Interfaces between Flightcrews and Modern Flight Deck Systems. 1996.
- Gannett, J.R. "The Pilot and the Flight Management System". Behavioral Objectives in Aviation Automated Systems Symposium (pp. 93-96). Society of Automotive Engineers, Warrendale, PA, 1982.
- Gras, A., Moricot, C., Poirot-Delpech, S.L., and Scardigli, V. "Le pilote, le controleur et l'automate". Published report (in French), Université de Paris (Pantheon Sorbonne), Paris, 1990.
- Grieve, S. *The Impact on the Airlines of the "New Technology" Aircraft*. United Kingdom.
- Hersh, S.M. *The Target is Destroyed*. Random House: New York, 1986.
- Hoagland, M. "Winging it in the 1980s: Why Guidelines are Needed for Cockpit Automation". Third Aerospace Technology Conference Proceedings (pp. 155-162). Society of Automotive Engineers, Warrendale, PA, 1984.
- Hopkins, H. "Over-dependence on Automatics - The Black Box One Man Band". *International Journal of Air Safety*, No. 1 (1983), pp. 343-348.
- Hoffman, W.C. and Hollister, W.M. "Forecast of the General Aviation Air Traffic Control Environment for the 1980s". NASA Contractor Report CR-137909, 1976. Aerospace Systems, Inc., Burlington, MA.
- Lerner, E.J. "The Automated Cockpit". *IEEE Spectrum*, No. 20 (1983), pp. 57-62.

- Loomis, J.P., and Porter, R.F. "The Performance of Warning Systems in Avoiding Controlled-Flight-into-terrain (CFIT) Accidents". Presented at Symposium on Aviation Psychology, Columbus, Ohio State University, 1981.
- Mackley, W.B. "Aftermath of Mt. Erebus". *Flight Safety Digest*, No. 1 (1982), pp. 3-7.
- Mahon, P. *Verdict on Erebus*. Collins: Auckland, New Zealand, 1984.
- McCormick E.J. and Sanders, M.S. *Human Factors in Engineering and Design*. McGraw-Hill: New York, 1982.
- Melvin, W.W. "A Philosophy of Automation". Behavioral Objectives in Aviation Automated Systems Symposium (pp. 319-325). Society of Automotive Engineers, Warrendale, PA, 1983.
- Morters, K. "B-767 Flight Deck Automation Research" (unpublished report). Australia, 1988.
- Nagel, D.C. "Automation and Human Error". Paper presented at Air Line Pilots Association Symposium "Beyond Pilot Error". Washington, D.C., 1983.
- Oliver, J.G. "A Single Red Light". Paper presented at Air Line Pilots Association Annual Safety Symposium, Washington, D.C., 1984.
- Rasmussen, J. and Rouse, W.B. *Human Detection and Diagnosis of System Failures*. Plenum Press: New York, 1981.
- Rasmussen, J. "Models of Mental Strategies in Process Plant Diagnosis". *Human Detection and Diagnosis of System Failures*, J. Rasmussen, W.B. Rouse (Eds.). Plenum Press: New York, 1981.
- Rasmussen, J. "Reflections on the Concept of Operator Workload". *Mental Workload: Its Theory and Measurement*, N. Moray (Ed.). Plenum Press: New York, 1979.
- Rohmer, R. *Massacre 747*. PaperJack Publishers: Markham, Ontario, 1984.
- Ruffell Smith, H.P. "Some Human Factors of Aircraft Accidents During Collision with High Ground". *Journal of Institute of Navigation*, No. 21 (1968), pp. 1-10.
- Sheridan, T.B. "Understanding Human Error and Aiding Human Diagnostic Behaviour in Nuclear Power Plants". *Human Detection and Diagnosis of System Failures*, J. Rasmussen and W.B. Rouse, Eds. Plenum Press: New York, 1981.
- Sheridan, T.B. and Johannsen, G. (Eds.). *Monitoring Behaviour and Supervisory Control*. Plenum Press: New York, 1976.
- Speyer, J-J. "Cockpit Design-induced Error Tolerance". Paper presented at Orient Airlines Association Flight Safety Seminar, 1987.
- Speyer, J-J, and Blomberg, R.D. "Workload and Automation". *Human Error Avoidance Techniques*, Society of Automotive Engineers, Warrendale PA, 1989.
- Thompson, D.A. "Commercial Aircrew Detection of System Failures: State of the Art and Future Trends". *Human Detection and Diagnosis of System Failures*, J. Rasmussen and W.B. Rouse, Eds. Plenum Press: New York, 1981.
- Vette, G. *Impact Erebus*. Hodder and Stoughton: Auckland, New Zealand, 1983.
- White, T.N. "Modelling the Human Operator's Supervisory Behaviour". First European Annual Conference on Human Decision-making and Manual Control, H.G. Stassen (Ed.). Plenum Press: New York, 1981.
- Wiener, E.L. "Controlled Flight into Terrain Accidents: System-induced Errors". *Human Factors*, No. 19 (1977), pp. 171-181.
- Wiener, E.L. "Midair Collisions: The Accidents, the Systems, and the Realpolitik". *Human Factors*, No. 22 (1980), pp. 521-533.
- Wiener, E.L. "Cockpit automation: In need of a philosophy". Proceedings of Behavioral Engineering Conference (pp. 369-375). Society of Automotive Engineers, Warrendale, PA, 1985.
- Wiener, E. L. and Nagel, D.C. *Human Factors in Aviation*. Academic Press: San Diego, 1988.
- Wiener, E.L., and Nagel, D.C. "Errors and Error Management in High Technology Aircraft". Proceedings of the Seventh Meeting of Aeronautical and Space Medicine, Paris Air Show, 1989.
- Wiener, E.L. "Human Factors of Cockpit Automation: A Field Study of Flight Crew Transition. (NASA Contractor Report CR-177333. NASA-Ames Research Center, Moffett Field, CA, 1985.

Wiener, E.L. and Curry, R.E. "Flight-deck Automation: Promises and Problems". *Ergonomics*, No. 23 (1980), pp. 955-1011.

Wiener, E.L. "Beyond the Sterile Cockpit". *Human Factors*, No. 27 (1985), pp. 75-90.

Wiener, E.L. (1984). "Vigilance and Inspection". *Sustained Attention in Human Performance*, Warm, J. (Ed.). Wiley: London, 1984.

Woods, D.D., Johannesen, L.J., Cook, R.I. and Sarter, N.B. Behind human error: Cognitive systems, computers and hindsight. CSERIAC.

---

## Appendix 1 to Chapter 3

# FIELD STUDIES IN AUTOMATION

1. Field studies are a window on the real world. The several established safety deficiencies reporting systems are another window on the real world. Through them, important lessons can be learned about the operation of the world. Since it is not the intention to duplicate existing documentation, this appendix provides only an overview of existing field studies in automation. The Secretariat will assist those interested in obtaining more detailed information in securing such information at its source.

2. Field studies are important for several reasons:

- Flight crews are the ones who see and know the way airplanes are operated in the real world. They are actually involved, and their experience and advice should be sought.
- Problems often do not appear until after line experience has been accumulated. Line flying is the real test of design, since that is where the equipment is used under a variety of conditions. An additional focus of field and reporting studies is to provide feedback from the operational world to those who are not in the operational world.
- Field studies allow for impartial evaluation of the system, since researchers conducting the study are not involved in design, sales or operation of the aircraft, or enforcement of regulations. Field studies can provide important feedback to designers and operators, as well to other researchers.

3. The basic sources of information in field studies are questionnaires for use with volunteer crews and structured "callbacks" made in volunteer reporting systems. Face-to-face interviews are also used, involving instructor pilots, management pilots, simulator instructors and ground school instructors. Researchers may also attend ground school training for the aircraft type involved, and make observation rides in the flight deck. To the present date, three of the major published field studies in automation are:

- The Introduction of New Cockpit Technology: A Human Factors Study, by Renwick E. Curry, 1985,

in reference to crew transition to Boeing B-767 aircraft.

- Human Factors of Cockpit Automation: A Field Study of Flight Crew Transition, by Earl L. Wiener, 1985, in reference to crew transition to McDonnell-Douglas MD-80 aircraft.
- Human Factors of Advanced Technology ("Glass Cockpit") Transport Aircraft, by Earl L. Wiener, 1989, in reference to error analysis, crew coordination, training, and workload in Boeing B-757 aircraft.

These three studies were sponsored by NASA, and they are available from NASA Ames. Another major survey was conducted by one operator in the Airbus A-310 cockpit systems. The Civil Aviation Authority of the United Kingdom distributed an automation questionnaire to survey the current opinions of pilots in the United Kingdom on cockpit automation, and to identify areas that might benefit from more research or study. The conclusions to which it arrived bear no significant differences with those produced by other field studies. In addition, individual operators and organizations have conducted internal surveys or pilot questionnaires aimed at identifying particular shortcomings applicable to their specific operations.

### THE INTRODUCTION OF NEW COCKPIT TECHNOLOGY: A HUMAN FACTORS STUDY

4. The objectives of this study were:

- to identify any adverse reactions to the new technology,
- to provide a "clearing house" of information for the airlines and pilots on experiences during the introductory period of the B-767,
- to provide feedback on airline training programmes for the new aircraft, and

- to provide field data to NASA and other researchers to help them develop principles of human interaction with automated systems.

Three airlines and more than one hundred pilots agreed to participate in the study. The data were taken during the early introduction of the B-767 and the conclusions apply only to that period.

5. The conclusions of this study were:

- Most pilots enjoy flying the B-767 more than they enjoy flying the older airplanes (This conclusion must be interpreted as a generic observation. It reflects the pilots' appraisal of an ADVTECH airplane rather than a specific type).
- The pilots accept the new technology, and they choose to use it because they find it useful.
- The pilots are aware of the possible loss of flying skills with the presence of automation, and they hand-fly (usually with flight director) to prevent this loss. The data collected in this study do not indicate any loss of skills.
- The primary points of confusion or surprise were autothrottle/autopilot interactions; the autopilot turning the "wrong way" or not capturing the course; and achieving (or not achieving) desired results with the Flight Management System/Control Display Unit (FMS/CDU).
- The pilots felt training for the FMS/CDU could be improved, and they specially wanted more "hands-on" experience. More training on the mode control panel, and more hand flying were mentioned.
- Information, especially "techniques", may not always be getting from the system designers to the line pilots.
- Flying any aircraft with sophisticated equipment and high levels of automation allows distractions that cause a loss of monitoring performance.
- Pilots should be trained to "turn it off" and not try to "program" their way out of an anomalous situation.
- These field data confirm some existing Human Factors principles, suggest some new principles, and raise questions requiring further research.

### HUMAN FACTORS OF COCKPIT AUTOMATION: A FIELD STUDY OF FLIGHT CREW TRANSITION

6. This was a field study involving two groups of airline pilots (from the same airline) over a two-year period to determine what factors affected their transition from traditional airline cockpits to a highly automated version (DC-9/10/30/50 to MD-80). The conclusions of the study were as follows:

- The MD-80, its Flight Guidance System and other automatic features are generally viewed by the pilots who fly it as well conceived and well designed, and are held in high regard.
- Pilots expressed a favourable overall view about automation. However, even the more enthusiastic defenders of automation expressed concern over the increasing degree of monitoring required by automatic equipment. Some concern was also voiced about the pilots being "out of the loop" or "along for the ride".
- There was over-all high usage of automatic features, but with large variations in individual degree of usage. Pilots felt that automation should be provided by the company, but that it should be left to each individual to determine when and under what circumstances he would choose to use or not use the automatic features.
- After an initial period of concern about the reliability of the automatic equipment, most crews felt that the equipment was highly reliable. The major concern voiced was that it required a degree of monitoring that was beyond what they had been accustomed to in the earlier DC-9's.
- There were mixed feelings on the subject of workload reduction. The consensus was that if a number had to be placed on workload reduction, it would be around 15 per cent, far short of the expectations for the MD-80.
- Pilots were unanimous in reporting that compared to the DC-9, the automation and cockpit configuration of the MD-80 did not allow any additional time for extra-cockpit scanning.
- Most pilots did not see any safety advantage to the automatic features. Their attitude towards the safety aspects of automation was essentially neutral.

- This study did not provide solid evidence on questions relating to loss of proficiency due to overreliance on automation. Even when some concern was expressed, none saw this as a serious problem. This may be in part because, at the beginning of the study, crews were flying mixed blocks of MD-80 and traditional DC-9 time.
- During the period of the study, a "separate status" between conventional and advanced models was established. Pilots impacted by this status reported that transition was made considerably smoother by the opportunity to fly only the MD-80 during the initial period of exposure to the new cockpit.
- Learning to control a new technology flight deck requires a new approach to training. It is inefficient to use a whole-task simulator for training in programming and cognitive (mental) skills. What is needed is a family of dynamic, interactive training devices which are capable of demonstrating to the pilot trainee in real time the dynamics of the aircraft systems and the consequences of his actions. It is a significant comment on the quality of training that crews repeatedly mentioned that whenever the slightest unexpected event occurred, such as a change in runway, they would "click it off" (go to a manual mode).
- Continuing attention must be paid to basic and traditional Human Factors problems in the design of cockpits: control design, keyboard entry devices, warning and alerting systems, and cockpit lighting. The effective employment of new technology in the flight deck depends on time-honoured Human Factors principles.
- The study did not find signs of automation-induced psychosocial problems such as negativity toward flying as an occupation, or loss of self-esteem.
- *General findings.* Pilots exhibit a high degree of enthusiasm for the aircraft, their training and the opportunity to fly state-of-the-art transport aircraft. It is more difficult to summarize the pilots' attitudes towards automation in general, an area in which "mixed feelings" predominate. Strong reservations were expressed in two critical areas: safety (pilots feel that they are often "out of the loop" and lose situational awareness); and workload (pilots feel it increases during phases of the flight already characterized by high workload, and decreases during periods of low workload). Pilots tend to revert to manual modes of flight guidance ("click it off") in times of high workload.
- *Equipment.* Pilots report satisfaction with the general layout of the cockpit, and few problems in the area of traditional Human Factors. The warning and alerting systems of the 757 deserve high praise in the view of most pilots.
- *Training.* Training for the 757 at both airlines in this study was generally considered well planned and well conducted. The most common criticism is an over-emphasis on automation to the exclusion of basic airplane knowledge and skills. The need for computer-based, part-task simulation devices is evident.
- *Cockpit errors.* The study did not provide evidence to assert whether high or low automation aircraft generate more crew errors. Altitude deviations, one area of great concern, are usually more often traceable to human error than to equipment failure.
- *Crew co-ordination.* Compared to traditional models, it is physically difficult for one pilot to see and understand what the other is doing. There is a less clear demarcation of "who does what" than in traditional cockpits; this is due to the tendency of the crew to "help" each other with programming duties when the workload increases. The modern cockpit also seems to produce an unintended redistribution of authority from the captain to the first officer.
- *Workload.* The study does not demonstrate that a clear case for automation bringing an overall reduction in workload can be made, especially during phases of high workload when that reduction is most needed. Positive evidence was obtained, however, that some automatic features placed in the aircraft in the hope of reducing workload, are perceived by the pilot as workload inducing. The conclusion is that the present generation of

#### HUMAN FACTORS OF ADVANCED TECHNOLOGY ("GLASS COCKPIT") TRANSPORT AIRCRAFT

7. This is a report of a three-year field study of airline crews at two major airlines who were flying an advanced technology aircraft, the Boeing 757. The two previous studies concentrated on initial transition of the flight crews and their early experience. This report concentrates in four major topics: training for advanced automation; cockpit errors and error reduction; management of cockpit workload; and general attitudes towards cockpit automation. The conclusions of the study are:

advanced technology aircraft has failed to realize its potential for workload reduction for both internal reasons, and reasons external to the hardware and software design.

- *Air Traffic Control.* The present ATC system does not allow full exploitation of the flight guidance capabilities of automated aircraft. It seems that aircraft and ground-based ATC systems were designed, developed, and manufactured almost as if they were unrelated and independent systems.

8. In its conclusion, this study offers the following recommendations:

- Research should continue on human-automation interfaces.
- Research into making the ATC system more receptive to the capabilities of advanced aircraft should be conducted on a priority basis before the new generation ATC systems are placed on line.
- Training departments should reexamine their training programmes, syllabi, training equipment and support materials to be certain that they have been responsive to necessary changes brought by the new aircraft.
- Operators of modern, two-pilot aircraft should reexamine their procedures, checklists, flight plans, weather information, fuel slips, manuals, and company demands on the flight crew for opportunities to reduce workload and operational errors by providing optimal support material, and eliminating unnecessary procedures.
- Research should be launched into crew resource management as it may differ in advanced versus traditional cockpits.
- Authorities should re-examine certification procedures with the goal of carefully evaluating the Human Factors aspects of new models. Human Factors other than merely estimates of workload should be considered, making use of error-predictive techniques.
- Agencies should encourage research into error-tolerant systems and other methods of exploiting machine intelligence to prevent, trap, or make more apparent errors made by the flight crew.
- Manufacturers and users should standardize terminology and designations of nav aids across the CDU, charts and computer-produced flight plans.

- In general, future cockpits should be designed to provide automation that is human centred rather than technology driven.

### LUFTHANSA COCKPIT SYSTEMS SURVEY: A-310

9. This operator uses cockpit surveys to obtain up-to-date information and feedback from their flight crews as a basis for cockpit specifications. The selected tool is an anonymous questionnaire, which comprises two parts: Part 1: cockpit layout, general handling qualities and airplane systems, and electronic crew interfaces (ECAM, EFIS, AFS, and FMS). Part 2 (electronic interfaces) of the survey was subdivided into four main topic areas according to a standard human-machine interface model:

- *Physical interface (reach and see)* — control location, reach and handling, display location, readability, colour and lighting, etc.
- *Interface dialogue or operational considerations (understanding)* — ease of understanding of operational rules, display rules, interlocks, and amount and kind of required training.
- *Interface tools (usability)* — general usefulness, adequateness and importance of features.
- *Organizational aspects of the interface (appropriateness in the operational environment)* — factors like reliability, logistics, ATC constraints, etc.

10. These four main topic areas were surveyed in the Electronic Centralized Aircraft Monitoring (ECAM), Electronic Flight Instrument System (EFIS), Autoflight System (AFS), and Flight Management System (FMS). The conclusions of the survey were:

- Over-all, pilots surveyed like automation.
- Flying with automatics must be as good or better than flying manually.
- Some problems do occur with automation: "keeping the pilot in the loop" is a mandatory requirement for any automated function.
- FMS and ECAM are both well liked, however, both systems are not yet optimally designed. Initial

development of the FMS was promoted and tested by a relatively small group of pilots. Further development should be based on a broad (international) range of airline experience.

- Advanced flight management systems must incorporate an improved crew interface, higher computational performance, and a better fit to the ATC environment.
-



## Appendix 2 to Chapter 3

# AUTOMATION PRINCIPLES FROM WIENER AND CURRY (1980)

### CONTROL TASKS

1. System operation should be easily interpretable or understandable by the operator, to facilitate the detection of improper operation and to facilitate the diagnosis of malfunctions.
2. Design the automatic system to perform the task the way the user wants it done (consistent with other constraints such as safety); this may require user control of certain parameters, such as system gains (see Principle No. 5). Many users of automated systems find that the systems do not perform the function in the manner desired by the operator. For example autopilots, especially older designs, have too much "wing waggle" for passenger comfort when tracking ground-based navigation stations. Thus, many airline pilots do not use this feature, even when travelling coast-to-coast on non-stop flights.
3. Design the automation to prevent peak levels of task demand from becoming excessive (this may vary from operator to operator). System monitoring is not only a legitimate, but a necessary activity of the human operator; however, it generally takes second priority to other, event-driven tasks. Keeping task demand at reasonable levels will ensure available time for monitoring.
4. For most complex systems, it is very difficult for the computer to sense when the task demands on the operator are too high. Thus the operator must be trained and motivated to use automation as an additional resource (i.e. as a helper).
5. Desires and needs for automation will vary with operators, and with time for any one operator. Allow for different operator "styles" (choice of automation) when feasible.
6. Ensure that over-all system performance will be insensitive to different options, or styles of operation. For example, the pilot may choose to have the autopilot either fly pilot-selected headings or track ground-based navigation stations.

7. Provide a means for checking the set-up and information input to automatic systems. Many automatic system failures have been and will continue to be due to set-up error, rather than hardware failures. The automatic system itself can check some of the set-up, but independent error-checking equipment/procedures should be provided when appropriate.

8. Extensive training is required for operators working with automated equipment, not only to ensure proper operation and set-up, but to impart a knowledge of correct operation (for anomaly detection) and malfunction procedures (for diagnosis and treatment).

### MONITORING TASKS

9. Operators should be trained, motivated, and evaluated to monitor effectively.
10. If automation reduces task demands to low levels, provide meaningful duties to maintain operator involvement and resistance to distraction. Many others have recommended adding tasks, but it is extremely important that any additional duties be meaningful (not "make-work") and directed toward the primary task itself.
11. Keep false alarm rates within acceptable limits (recognize the behavioral impact of excessive false alarms).
12. Alarms with more than one mode, or more than one condition that can trigger the alarm for a mode, must clearly indicate which condition is responsible for the alarm display.
13. When response time is not critical, most operators will attempt to check the validity of the alarm. Provide information in a proper format so that this validity check can be made quickly and accurately and not become a source of distraction. Also provide the operator with information and controls to diagnose the automatic system and warning system operation. Some of these should be easy, quick checks of sensors and indicators (such as the

familiar "press to test" for light bulbs); larger systems may require logic tests.

14. The format of the alarm should indicate the degree of emergency. Multiple levels of urgency of the same condition may be beneficial.

15. Devise training techniques and possible training hardware (including part- and whole-task simulators) to ensure that flight-crews are exposed to all forms of alerts and to many of the possible conditions of alerts, and that they understand how to deal with them.

---

## **Appendix 3 to Chapter 3**

# **STATEMENT OF AUTOMATION PHILOSOPHY, DELTA AIR LINES (1990)**

The word "automation", where it appears in this statement, shall mean the replacement of a human function, either manual or cognitive, with a machine function. This definition applies to all levels of automation in all airplanes flown by this airline. The purpose of automation is to aid the pilot in doing his or her job.

The pilot is the most complex, capable and flexible component of the air transport system, and as such is best suited to determine the optional use of resources in any given situation.

Pilots must be proficient in operating their airplanes in all levels of automation. They must be knowledgeable in the selection of the appropriate degree of automation, and

must have the skills needed to move from one level of automation to another.

Automation should be used at the level most appropriate to enhance the priorities of Safety, Passenger Comfort, Public Relations, Schedule, and Economy, as stated in the Flight Operations Policy Manual.

In order to achieve the above priorities, all Delta Air Lines training programs, training devices, procedures, checklists, aircraft and equipment acquisitions, manuals, quality control programs, standardization, supporting documents and the day-to-day operation of Delta aircraft shall be in accordance with this statement of philosophy.

---

# CHAPTER 4

## HUMAN FACTORS TRAINING FOR SAFETY INVESTIGATORS

### 4.1 INTRODUCTION

4.1.1 Human Factors issues are involved in most aviation occurrences. Thus, to advance aviation safety, we must improve our ability to identify the involvement of Human Factors issues in accidents and incidents. By doing so we can learn more from these experiences and implement new and better measures to prevent repetitive occurrences. We cannot prevent humans from making errors, but we can certainly reduce the frequency and minimize the consequences. This is one fundamental reason behind ICAO's accident prevention programmes.

4.1.2 This chapter presents information upon which the Human Factors training curricula for accident investigators can be developed. It has three purposes:

- to provide the basic contents which should be included in a Human Factors training course for accident investigators;
- to provide investigators and investigation authorities, civil aviation regulatory authorities, company/corporate management, and other aviation personnel with information on the need for and purpose of the investigation of Human Factors;
- to outline a methodology for investigating Human Factors in aircraft accidents and incidents; and
- to describe how the information gathered should be reported.

4.1.3 This chapter is intended to complement the ICAO *Manual of Aircraft Accident Investigation* (Doc 6920). (Further information applicable to the training of accident investigators can be found in Part 1, Chapters 1 and 2 of the manual.) The philosophical approach outlined in this chapter should be understood when applying the practical guidance provided in the investigation and prevention manuals. Human Factors also encompasses medical issues; however, the thrust of this chapter is on the non-medical aspects.

4.1.4 The primary focus of this chapter is on the events which led up to the occurrence and not on post-accident events, such as search and rescue or survivability issues. It will not include guidance for handling post-mortems, toxicological examinations and injury pattern analysis. These special areas are discussed in the *Manual of Aircraft Accident Investigation* and the *Manual of Civil Aviation Medicine* (Doc 8984). Nevertheless, the investigator is expected to be familiar with the physiological as well as the psychological aspects of human performance.

4.1.5 Through the international Standards and Recommended Practices (SARPs) set forth in Annex 13 to the Chicago Convention and related guidance material, ICAO has assisted States in the accident investigation and prevention field. There is a continued emphasis on objectivity in investigation and prevention. Improvements in the investigation of Human Factors in accidents and incidents will add significantly to this effort.

4.1.6 This chapter:

- discusses the need for and the purpose of Human Factors investigation; addresses some of the obstacles to Human Factors investigation; discusses the nature of human error and accidents; and provides a systems approach model by which the scope of the Human Factors investigation can be determined;
- addresses the conduct of the Human Factors investigation; discusses the organization and management of the investigation; details who should conduct the investigation, what information should be collected, where it can be found, and presents a discussion on how to analyze the information collected;
- discusses the reporting of accidents and incidents with the emphasis on the treatment of Human Factors information, the identification of hazards and the development of safety action to prevent recurrence;

- provides examples of Human Factors Checklists (see Appendix 1);
- provides guidance in Witness Interviewing Techniques (see Appendix 2);
- presents a sample listing of Explanatory Factors — a proposed expansion of the ADREP Manual (see Appendix 3);
- provides a listing of available accident/incident data bases (see Appendix 4).

## 4.2 NEED FOR AND PURPOSE OF HUMAN FACTORS INVESTIGATION

### Background

4.2.1 As evidenced by investigation records dating back to the 1940s, Human Factors issues are involved in the majority of aviation accidents and incidents. Regardless of the actual percentage, there is little disagreement among government and industry experts over the importance of Human Factors as a primary element in the causes of accidents and incidents. In spite of this knowledge, and the notion that “to err is human”, progress has been slow in adopting a uniform approach to the investigation of Human Factors in aviation occurrences. When no tangible technical evidence was found to explain the occurrence, investigators and their authorities sometimes found it difficult to deal with Human Factors issues. The unfortunate result has been described by George B. Parker, Associate Professor of Safety at the University of Southern California, as the Law of Exception: *If we have ruled out everything except the pilot, the cause must be pilot factor.*

4.2.2 Accident investigation reports usually depict clearly what happened and when, but in too many instances they stop short of fully explaining how and why the accidents occurred. Attempts to identify, analyse, and understand the underlying problems that led to the breakdowns in human performance and thus to the accidents are sometimes inconsistent. By stating that a pilot did not follow the rules implies that the rules are well-founded, safe, and appropriate. Hence, the investigation reports often limit conclusions to phrases such as “pilot error”, “failed to see and avoid”, “improper use of controls”, or “failed to observe and adhere to established standard operating procedures (SOPs).” This narrow focus is but one of many obstacles to the effective investigation of Human Factors.

4.2.3 Below are listed other common obstacles, along with solutions which can eliminate them.

### Obstacles and solutions

**Obstacle:** The need to investigate Human Factors issues has not been readily accepted. One may hear comments, such as “Human Factors is an area that is too *soft*”, “human nature cannot be changed”, or “it is too difficult to prove conclusively that these factors contributed to the accident”.

**Solution:** More education, describing how experimental research has managed to eliminate many speculative elements in the field of Human Factors, with scientifically supported documentation. For example, research has shown empirically the advantages of effective cockpit communication, a recognition that has translated directly into courses in crew resource management and pilot decision-making.

**Obstacle:** The reluctance to investigate Human Factors may stem from a lack of understanding of what the term “Human Factors” encompasses. Unfortunately, some investigators believe themselves ill-equipped because they are not medical doctors or psychologists. The field of Human Factors extends well beyond the physiological and the *psychological*; ironically, most investigators, unbeknown to themselves, have a broad awareness of the subject which they apply in an informal manner.

**Solution:** Better Human Factors training for investigators will develop a more thorough understanding of what the investigation of Human Factors entails.

**Obstacle:** Investigators may mishandle questions related to the performance of crew members, air traffic controllers, maintenance personnel, and others. This can happen when the investigator has not established an atmosphere of objectivity and trust, and those whose performance is being questioned feel threatened by or antagonistic towards the investigator. In the worst case, crew members or other interested parties may withhold valuable information and assistance from the investigation authority.

**Solution:** Investigators should ensure that people understand the objective of the process — to prevent recurrence — and the method by which the investigator intends to achieve this objective. If there is a possibility of misunderstanding, this information should be discussed openly at the beginning of the investigation.

**Obstacle:** There is often a natural reluctance on the part of witnesses (for the purposes of this chapter these include peers, supervisors, management and spouses) to speak candidly about the deceased. Also, investigators may be somewhat reluctant to ask questions which may be interpreted as unfavourable by a relative, friend or colleague.

**Solution:** Well planned interviews are required. By comparing the information obtained through these interviews to information gathered by other means in the investigation process, a more complete explanation can be achieved.

**Obstacle:** Balancing an individual's right to privacy with the need to uncover and report on the factors involved in the accident is another difficulty. On the one hand, information from the cockpit voice recorder (CVR), air traffic control (ATC) recordings, and witness statements may be essential in determining how and why the accident occurred. On the other hand, these same sources often contain sensitive personal information about involved individuals who would naturally want such information protected.

**Solution:** Accident investigation authorities should provide a degree of protection to such sources (see Annex 13, Chapter 5). Depending on an individual State's laws, this protection may need to be legislated. Investigation authorities will have to be discriminating, publishing only that information which is essential to the understanding of the accident and which promotes prevention.

**Obstacle:** The investigation philosophy adopted by the management of the investigation authorities is very important. Investigators will be hampered in their efforts to conduct a full systematic investigation if the management for whom they work do not believe in the importance of investigating Human Factors in accidents and incidents. Without management support, there is little doubt this field will continue to be neglected.

**Solution:** Knowledge of Human Factors and an understanding of how to apply this knowledge in an investigation offers the investigation authority a greater opportunity to identify root causes which may not have been recognized previously. Furthermore, it offers States' administrations a constructive means for handling controversial human performance issues. Some of the key methods by which investigators and their managers can promote the investigation of Human Factors lie in keeping abreast of current literature, attending Human Factors courses and seminars, and applying concepts such as those outlined in this digest.

**Obstacle:** In many States, the regulatory authority also has the responsibility for investigating accidents and incidents. The absence of an independent investigation authority has the potential for creating a conflict of interest within the organization. There could be an unwillingness on the part of the regulators to investigate those issues that are related to their role as regulators. This situation could also cause the travelling public to view the regulator's investigative findings with scepticism.

**Solution:** Some States have created an independent investigative body whose sole mission is to determine the causes of accidents and make safety recommendations to prevent their recurrence. Such a body is free to make findings and recommendations without encumbrance.

**Obstacle:** The rush of media and litigants to find someone to blame to suit their own objectives may result in premature conclusions. For example, the pilot is sometimes made the scapegoat to reassure the public that an individual has been found responsible.

**Solution:** Investigators must be diligent in promoting the philosophy that only after a full, systematic investigation has been completed can all the causes be determined.

**Obstacle:** The determination of conclusions and causes by the investigation authority can inadvertently apportion blame, fault or liability. To the extent that this happens, the potential for preventing future accidents and incidents may be diminished. How States publish their findings thus becomes a crucial part of the process of preventing accidents.

**Solution:** Accident investigation reports which concentrate on identifying underlying problems instead of laying blame will contribute far more to the prevention of accidents. However, while every effort should be made to avoid assigning fault or liability, the reports must not refrain from reporting objectively and fully on the causes merely because fault or liability might be inferred from the report.

**Obstacle:** There is a general lack of accepted international guidance material in this field.

**Solution:** With the publication of this manual and the series of ICAO Human Factors digests, it is anticipated that the most significant obstacles to the investigation of Human Factors will be eliminated. By applying the approach outlined in this chapter, investigators and their authorities should feel more confident in conducting these investigations.

4.2.4 Despite these obstacles, attitudes are changing. Government and industry experts are emphasizing the value of investigating Human Factors in aviation accidents and incidents as part of the over-all aim of accident prevention and improved safety. ICAO recognizes this change in emphasis as a positive step taken by States to improve investigation procedures, techniques and prevention.

#### The nature of accidents and incidents

4.2.5 The investigation of Human Factors in aircraft accidents and incidents should be an integral part of the entire investigation and its resulting report. Humans do not act alone; they are but one element of a complex system. Often, the human is the last barrier that stops the sequence of events from causing an accident. However, when events combine and interact together to cause a catastrophe, the investigation authority must ensure that all elements of the complex system are investigated to understand why the accident happened. A systematic search for the "Why" is not intended to pinpoint a single cause, nor is it intended to assign blame or liability, nor even to excuse human error. Searching for the "Why" helps identify the underlying deficiencies that might cause other incidents or another accident to happen.

4.2.6 The formal definition of an accident is useful in determining the criteria for reporting the occurrence to the investigation authority and in identifying when an investigation should be conducted. The extent of an investigation will be governed by the investigation authority's legislative mandate. The investigation authority may not be able to investigate every occurrence in depth.

#### Definition of an accident and an incident

4.2.7 ICAO Annex 13, Chapter 1 defines an accident as:

"an occurrence associated with the operation of an aircraft which takes place between the time any person boards the aircraft with the intention of flight until such time as all such persons have disembarked, in which a person is fatally or seriously injured ... , the aircraft sustains damage or structural failure ... , or the aircraft is missing or is completely inaccessible".

An incident (which will be discussed later) is defined as:

"an occurrence, other than an accident, associated with the operation of an aircraft which affects or could affect the safety of operation".

#### Systems approach to the investigation of Human Factors

4.2.8 Having decided to initiate an investigation, the investigating authority must take an all-encompassing view of the occurrence if it expects to fulfil the purpose of the investigation. Adopting a systems approach to the investigation of accidents and incidents helps the investigator to identify the underlying causes in the complex air transportation system. It allows a better understanding of how various components of the system interacted and integrated to result in an accident, and in so doing points the way to remedial action. Many different approaches exist to help investigators identify the components at work and to analyse the information gathered. The following paragraphs present one such approach, one proposed by James Reason<sup>1</sup> on accident causation and depicted graphically in Figures 4-1 and 4-2.

4.2.9 James Reason views the aviation industry as a complex productive system. One of the basic elements of the system consists of the **decision-makers** (upper management, the company's corporate body or the regulatory body), who are responsible for setting goals and for managing available resources to achieve and balance two distinct goals: the goal of safety, and the goal of on-time and cost-effective transportation of passengers and cargo. A second key element is **line management** — those who implement the decisions made by upper management. For upper-management decisions and line management actions to result in effective and productive activities by the workforce involved, certain **preconditions** have to exist. For example, equipment must be available and reliable, the workforce has to be skilled, knowledgeable and motivated, and environmental conditions have to be safe. The final element — **defences or safeguards** — is usually in place to prevent foreseeable injury, damage or costly interruptions of service.

4.2.10 Illustrated in Figure 4-2 is Reason's model of how humans contribute to the breakdown of these complex, interactive and well-guarded systems to produce an accident. In the aviation context, "well-guarded" refers to the strict rules, high standards and sophisticated monitoring equipment in place. Because of technological progress and excellent defences, accidents seldom originate exclusively from the errors of operational personnel (front-line operators) or as a result of major equipment failures. Instead, they result from interactions of a series of failures

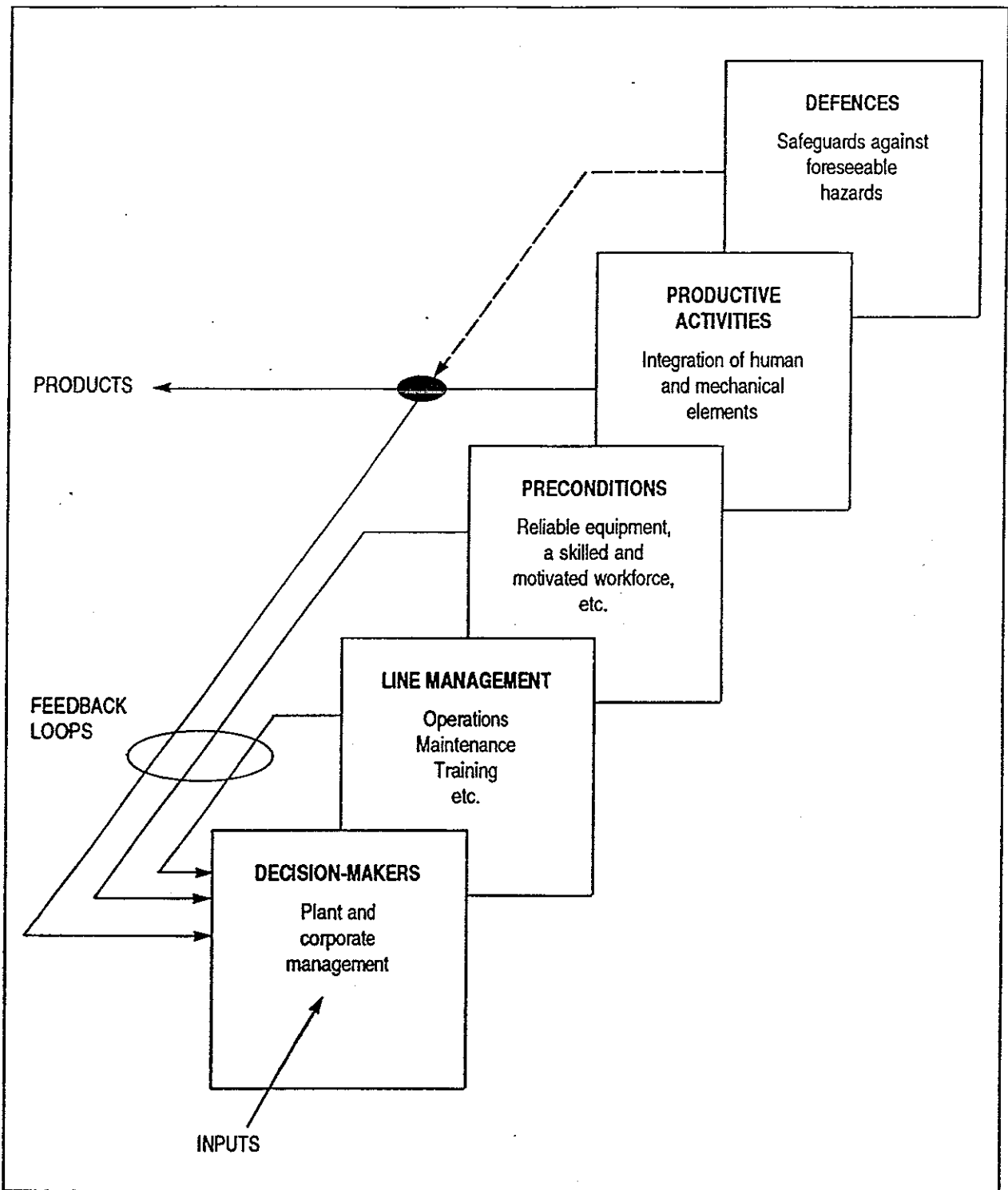

**Figure 4-1. The basic components of any productive system**  
(Source: James Reason, *Human Error*, 1990. United Kingdom: Cambridge University Press)



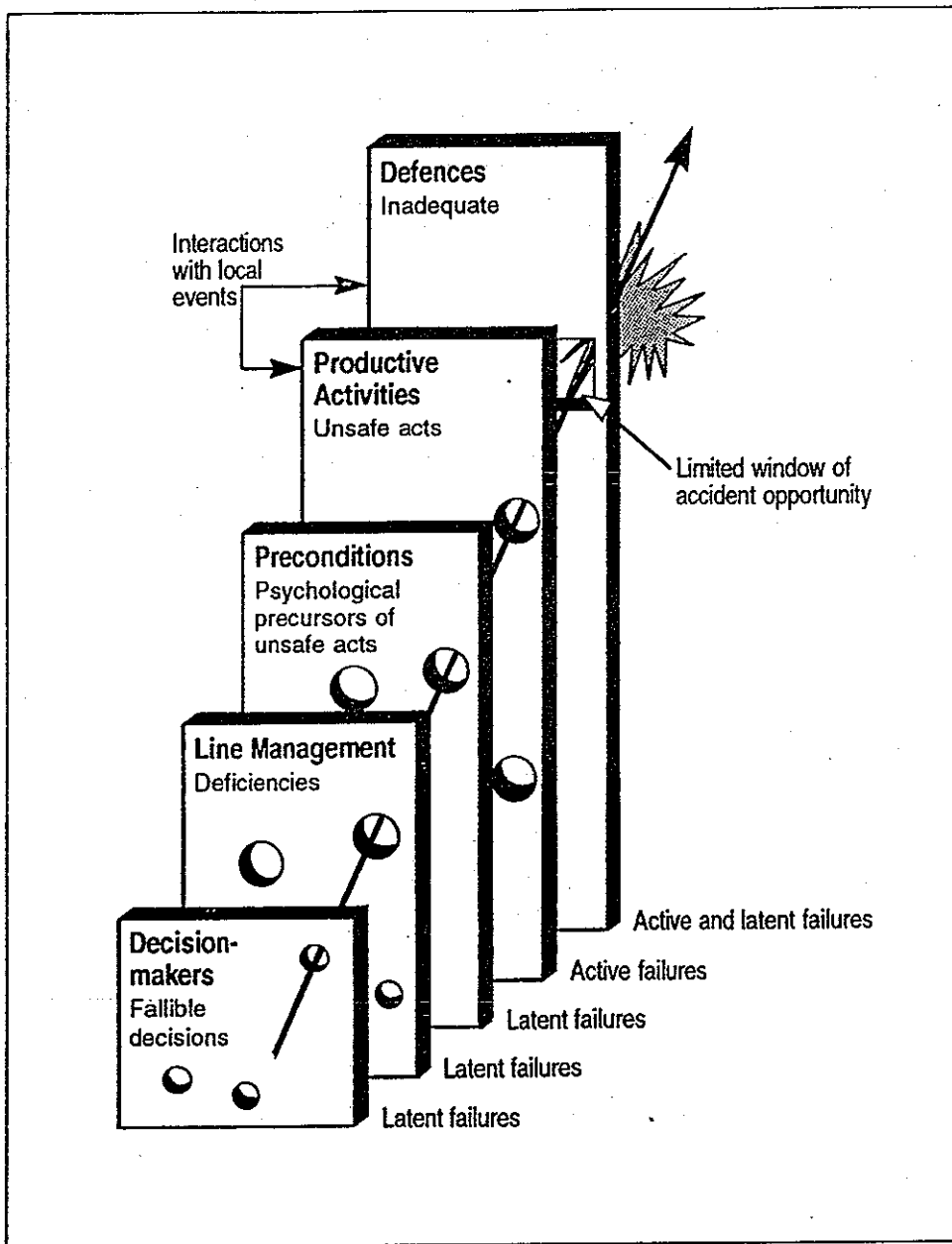

**Figure 4-2. Modified version of James Reason's model of accident causation, showing the various human contributions to the breakdown of a complex system**  
 (Source: James Reason, *Human Error*, 1990. United Kingdom: Cambridge University Press)

or flaws already present in the system. Many of these failures are not immediately visible, and they have delayed consequences.

4.2.11 Failures can be of two types, depending on the immediacy of their consequences. An active failure is an error or a violation which has an immediate adverse effect. Such errors are usually made by the front-line operator. A pilot raising the landing gear lever instead of the flap lever exemplifies this failure type. A latent failure is a result of a decision or an action made well before an accident, the consequences of which may lie dormant for a long time. Such failures usually originate at the decision-maker, regulator or line management level, that is, with people far removed in time and space from the event. A decision to merge two companies without providing training to standardize operating procedures illustrates the latent failure. These failures can also be introduced at any level of the system by the human condition — for example, through poor motivation or fatigue.

4.2.12 Latent failures, which originate from questionable decisions or incorrect actions, although not harmful if they occur in isolation, can interact to create “a window of opportunity” for a pilot, air traffic controller, or mechanic to commit an active failure which breaches all the defences of the system and results in an accident. The front-line operators are the inheritors of a system’s defects. They are the ones dealing with a situation in which technical problems, adverse conditions or their own actions will reveal the latent failures present in a system. In a well-guarded system, latent and active failures will interact, but they will not often breach the defences. When the defences work, the result is an incident; when they do not, it is an accident.

#### Accident scenario

4.2.13 Let us apply the main principles of Reason’s model to a complex accident scenario to provide a better understanding of how humans contribute to a breakdown of the aviation system. The following fictitious scenario, based on real-life events, fully illustrates all of the system components:

- *In the late hours of a summer Friday evening, while landing on a runway heavily contaminated with water, a twin-engine jet transport aircraft with four crew members and 65 passengers on board overran the westerly end of the runway at Anytown City airport. The aircraft came to rest in the mud a short distance beyond the end of the runway. There were no injuries to crew or passengers, and*
- *there was no apparent damage to the aircraft as a consequence of the overrun. However, a fire started and subsequently destroyed the aircraft.*
- *Anytown City is a popular summer resort. The predominant weather for a typical summer day is low stratus and fog in the early morning, which gradually develops into convective cloud as the air warms. Severe thunderstorms are common in the early afternoon and persist until the late evening hours. The whole region where Anytown City is situated is “thunderstorm country” during summer.*
- *The runway at Anytown is 4 520 feet long. It is a relatively wide runway with a steep downward slope to the west. It is served by a low-power, short-range, non-directional beacon (NDB), unreliable in convective weather. Runway lighting is low-intensity, and there are no approach lights or visual approach aids. It is a classic “black-hole” approach during night landings.*
- *The flight had originated at the airline’s main base, 400 km away. This was the second-to-last flight for the flight crew that day. They had reported for duty at 1130 hours and were due to be relieved at 2200 hours. The crew had been flying a different schedule for the last three weeks. This was the beginning of a new four-day schedule on another route. It had been a typical summer afternoon, with thunderstorms throughout the entire region. Anytown City had been affected by thunderstorms during the early afternoon. No forecast was available, and the captain had elected to delay the departure.*
- *The flight schedule was very tight, and the captain’s decision to delay created a number of additional delays for subsequent flights. The dispatcher working the flight did not bring to the flight crew’s attention the need to consider a contaminated runway operation at Anytown, and did not review the landing performance limitations with them. After a long delay, the captain decided to add contingency fuel and depart.*
- *Visual conditions were present at Anytown, although there were thunderstorms in the vicinity of the airport, as well as a persistent drizzle. With no other reported traffic, they were cleared for a night visual approach. After touchdown, the aircraft hydroplaned and overran the end of the runway slightly above taxiing speed.*

- *The captain was a very experienced pilot. He had been with the airline for many years, accumulating several thousand hours of flying time as a first officer in two other types of large jet aircraft. However, he had limited experience with the aircraft type he was flying the night of the accident. He had not had the occasion to fly into Anytown before because the larger aircraft types he had been flying previously did not operate into Anytown. This was his first month as a captain. He was a well-balanced individual, with no personal or professional behavioral extremes.*
- *At the time of the accident the first officer was very inexperienced. He had recently been hired by the airline and had only been flying the line for about a month. He had flown into Anytown on two other occasions with another captain, but only during the day. His training records indicated standard performance during induction into the airline's operations.*

4.2.14 Initially, the investigation would focus on determining what actually happened at Anytown. It was learned that it had rained heavily at the airport and that there was standing water on the runway. Readout of the flight recorders disclosed that the captain flew the approach with excess airspeed which resulted in the airplane touching down smoothly, but well beyond the touchdown zone, and then hydroplaning off the end. It was also determined that the captain neglected to consult the performance charts in the aircraft flight manual for the correct landing distance on a wet runway. Also, the first officer did not make the required callouts during the approach.

4.2.15 These unsafe flight crew actions could in and of themselves explain the overrun and focus the investigation on a conclusion of "crew error" as a cause for the accident. However, if one were to investigate further into the company's operational procedures and practices and look upstream for other factors influencing the crew's performance, one could identify additional active and latent failures which were present during the flight. So the investigation should not stop at the point where the crew made errors.

4.2.16 If the investigation were to determine whether any other unsafe acts occurred in the operation, it would discover that not only did the dispatcher fail to brief the captain on potential problems at the airport (as required by company procedure), but that the company's agent at Anytown had not reported to the dispatcher at

headquarters that heavy rain had fallen. Inspection of the runway revealed poor construction, paving and lack of adequate drainage. It was also discovered that maintenance and inspection of the NDB was not in accordance with prescribed procedures. Over the past month, other flight crews had reported on several occasions that the ground aid had given erratic indications during instrument approaches; no attempt had been made to rectify the problem.

4.2.17 With these facts in mind and by referring to the Reason model, it can be seen that the actions of other front-line operators were also unsafe and had an influence upon the performance of the flight crew and the outcome of the flight. These activities can be classified as active failures and are also linked to line-management and decision-makers' performance.

4.2.18 Next, the investigation should determine if there were any adverse pre-conditions under which the flight crew had to operate. These can be listed as follows: 1) a night non-precision instrument approach to an unfamiliar airport; 2) a poorly lit, short, wide and steeply sloping runway; 3) poor runway pavement and drainage; 4) a lack of reliable information on the performance of the NDB; 5) a lack of reliable information about the wind conditions; 6) a flight schedule which allowed only a 15-minute turnaround at Anytown; 7) an arrival delayed by two hours, compromising crew duty-time requirements; 8) an aircraft not equipped with thrust reversers; 9) an inadequately trained flight crew, inexperienced in the type of aircraft and at the airport; and 10) inadequate crash, fire, and rescue services.

4.2.19 The Reason model classifies these pre-conditions as latent failures, many of which lay dormant for some time before the accident and which were the consequences of line management and decision-maker actions or inactions. For example, pairing two pilots who were inexperienced in the type of aircraft and allowing the captain to operate into an unfamiliar airport with a non-precision approach procedure was the result of unsafe decisions made by line management. Also, the failure to follow up on reported discrepancies with the NDB and the failure to conduct adequate inspections of the airport indicate either a lack of awareness of the safety implications or a tolerance of hazards by the decision-maker's line management and the regulatory authority. The investigation found that pilots were not briefed on the use of performance charts for contaminated runways, nor did they practice hydroplaning avoidance techniques. These discrepancies can be attributed to both line and upper management's failure to provide adequate training.

4.2.20 At the roots of this occurrence were other "fallible decisions" made by both upper management levels within the company and in the regulatory authorities. Management had decided to operate a scheduled service at an airport with known deficiencies in facilities (poor lighting and approach aids, inadequate weather services). More importantly, they chose to operate without the required level of crash, fire and rescue services available at the airport. In addition, management selected this type of airplane for this route out of marketing and cost considerations, despite its unsuitability for all-weather operations at Anytown. Compounding the problem was the decision by the regulatory authority to certify the airport for scheduled air transport operations in spite of its significant safety deficiencies.

4.2.21 In Figure 4-3, the active and latent failures identified in this accident are depicted using Reason's model. The model portrays the interactive nature of the failures and how they defeated the defences that one might expect to find within this organizational and operational environment. It also depicts the critical importance of identifying latent failures as they relate to the prevention of future accidents.

4.2.22 In summary, this approach to the investigation of Human Factors encourages the investigator to go beyond the unsafe actions of front line operators to look for hazards that were already present in the system and which could contribute to future occurrences. This approach has direct implications for the prevention activities of operators and regulators, who must identify and eliminate or control latent failures.

#### Investigation of incidents

4.2.23 Most accidents, such as the Anytown one, originate in actions committed by reasonable, rational individuals who were acting to achieve an assigned task in what they perceived to be a responsible and professional manner<sup>2</sup>. These and other individuals had probably committed these same unsafe acts before *without* negative consequences because the conditions existing at the time did not favour the interaction of flawed decisions or deficiencies present in the system. Under different circumstances, the consequences of the Anytown situation might have been an incident rather than an accident.

4.2.24 Many incidents occur every day which may or may not require reporting by the investigation authority; some come very close to being accidents. Because there is no injury or little damage, these incidents might not be investigated. The need for an

investigation by either the investigation authority or the operator must be emphasized, however, because an incident investigation can often produce better accident prevention results than can an accident investigation.

4.2.25 In an incident, injury, damage and liability are generally reduced, and there is less associated publicity. As a result, more information is available and the atmosphere is less adversarial. Investigators and Human Factors specialists have a better opportunity to identify the underlying human performance issues involved. There is thus more likelihood of determining why the incidents occurred and, equally, how the defences in place prevented them from becoming accidents.

4.2.26 Knowledge of incidents, whether they are investigated in depth or not, provides significant insight into accident prevention. This realization has led to the establishment of several confidential safety deficiency reporting systems, and the evidence emerging from these constitutes a rich source of data on Human Factors in aviation.

#### Conclusions

4.2.27 An accident or incident is not solely the result of an action taken by one individual. The potential for an accident is created when human actions and latent failures present within an organization or the air transport system interact in a manner which breaches all of the defences.

4.2.28 The purpose of investigating Human Factors is to identify why actions lead to the breakdown in defences and result in accidents. This requires determining the related latent failures present at all levels of the organization (including the upper levels of management) and of the aviation system of which it is a part. It goes without saying that it is equally important to determine how these unsafe actions could have been prevented. We cannot prevent humans from making errors, but we can reduce the frequency of these errors and limit their consequences. This is the essence of prevention activities and highlights the importance of investigation and reporting of incidents.

### 4.3 CONDUCT OF THE INVESTIGATION

#### General

4.3.1 The investigation of Human Factors is an integral part of the investigation of an accident or incident.

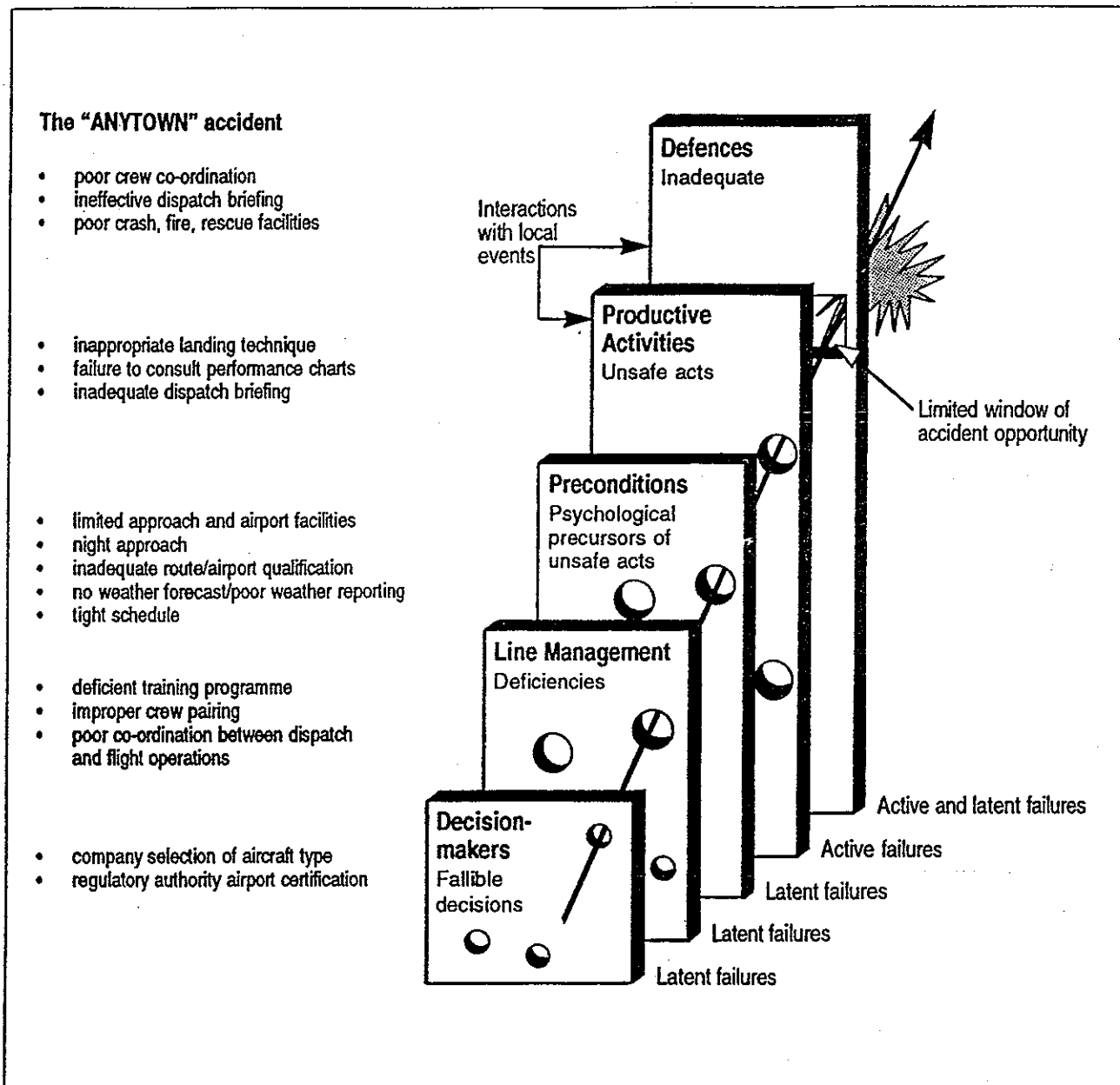

**Figure 4-3. How the "Anytown" accident fits the modified version of James Reason's model of accident causation**

The collection and analysis of Human Factors information should be just as methodical and complete as the collection and analysis of information pertaining to the aircraft, its systems, or any of the other traditional areas of investigation. The size and scope of the investigation of Human Factors will depend on the circumstances of the occurrence; it can involve one investigator who may also be responsible for all other aspects of the investigation, or one or more investigators dedicated solely to the investigation of Human Factors. Whether the investigation is large or small, many of the guidelines in this chapter for investigators' Human Factors training apply to both situations. The success of the investigation into Human Factors will depend on how well it is integrated and coordinated with the other elements of the investigation, and will require effective and efficient management of available resources through the application of basic management principles. The investigation itself should be viewed as a process requiring trained and disciplined investigators who apply skills in a systematic way.

4.3.2 This section provides guidelines to be used to integrate the investigation of Human Factors with the over-all investigation. It will look at who should conduct the investigation — a single investigator or a team — and outline what information should be collected, where to find it and how to analyse it.

#### Who should investigate?

4.3.3 Most accidents and incidents are investigated by investigators who are trained as generalists. For years, these generalists have been investigating highly technical and complex aspects of occurrences, including areas of Human Factors. Where necessary, specialists are consulted to provide specific assistance and guidance, but by and large the data gathering and analysis are conducted by the generalist investigators. ICAO sees no reason why this principle should not continue to apply to the investigation of Human Factors in aviation occurrences.

4.3.4 In view of the growing complexities of aviation, investigators must be knowledgeable of and skilled in the application of Human Factors principles and sound data-gathering and analysis techniques. They need not be physicians, psychologists, sociologists or ergonomists. The essential qualifications of a good Human Factors investigator are those of any good investigator. As outlined in ICAO's *Manual of Aircraft Accident Investigation* (Doc 6920), investigators must possess a sound working knowledge of aviation and of the factors which affect operations as a whole. This knowledge must

be complemented by technical skill, an inquisitive nature, dedication, diligence, patience, humility, integrity and logic. The measure of the good Human Factors investigator is not his or her professional qualifications in behavioural sciences, but rather the ability to determine, with the help of specialists if necessary, what information is relevant, to ask the right questions, to listen to the answers and to analyse the information gathered in a logical and practical way.

4.3.5 In order to adequately prepare generalist investigators to investigate Human Factors, it is essential that they receive appropriate training. Such training should include guidance on the interdisciplinary nature of this type of investigation, fundamental areas of examination, data that should be collected, data sources, data collection methods including interview techniques, and analysis techniques. Training should also include general guidance on the type of specialists who are available to assist, where they can be found and when it would be appropriate to employ them. Given this level of training, the experienced accident investigator should be able to conduct all but the most specialized aspects of the Human Factors investigation.

#### The single investigator

4.3.6 The single investigator assigned to investigate an accident or incident has the challenge of setting priorities and managing available time to cover effectively all areas of the investigation, including Human Factors.

4.3.7 As in any investigation, it is important for the investigator to take immediate steps to preserve evidence at the site and elsewhere. The single investigator will probably rely heavily on other authorities such as the police or airport officials. Good preplanning of the response is needed; the *Manual of Aircraft Accident Investigation* provides detailed guidance in this area. Once these initial steps have been taken, the investigator can begin to organize the investigation with the reasonable expectation that information which could be significant to its outcome, including areas of Human Factors, will be available for examination and analysis. At the outset, high priority must be assigned to the collection of information or evidence likely to disappear or to be forgotten, disturbed or unavailable soon after the accident.

4.3.8 The single investigator will also need to plan and prioritize the remaining work. Periodic assessments of progress are particularly important for the single investigator if precious time and resources are to be used effectively.

### The human factors investigator

4.3.9 When one investigator on a team is assigned to conduct the Human Factors portion of an investigation, the organizational task is less complex but the same basic principles apply. There must be close co-operation and interaction with all other investigation team members, as much of the information and data relevant to the investigation of the Human Factors aspects will actually be collected by investigators working in other areas.

### The human factors group

4.3.10 Depending on the circumstances of the accident, it may be desirable to establish a Human Factors Group under the direction of the Investigator-in-charge. Normally, such groups are established as a part of a large investigative team effort in response to a complex major aircraft accident. Although any investigator on the team may have some role in the investigation of Human Factors, the Human Factors group is responsible for co-ordinating the investigation of the human performance elements, ensuring that appropriate and sufficient data are collected, and synthesizing the results in a meaningful way.

4.3.11 The composition of the Human Factors Group will be governed by the nature of the occurrence. Because individuals whose performances are being examined are usually pilots, air traffic controllers, maintenance engineers, dispatchers, and operations managers, similarly qualified individuals are well suited to participate in the examination. As the investigation progresses, it may be advisable to alter the composition of the Human Factors Group, or to combine groups to provide sufficient expertise in relevant areas under examination.

4.3.12 Information collected by other members of the investigation team (such as operations, air traffic control, structures, systems, power plants, flight recorders, aircraft performance, etc.) is also required to reconstruct the sequence of events before actions and the performance of the front-line operators involved can be examined thoroughly. The Human Factors group must be able to rely on the assistance and expertise of these other groups.

### What information should be collected?

4.3.13 In general, the data that must be collected fall into two broad areas: information which will enable investigators to construct a detailed chronology of each significant event known to have occurred prior to and, if

appropriate, following the occurrence (this chronology must place particular emphasis on the behavioural events, and what effect they may have had on the accident events sequence); and information which will permit investigators to make reasonable inferences about factors which may have influenced or motivated a particular accident-producing behaviour. In terms of the Reason model, this is information which describes the "pre-conditions" under which front-line operators were working.

4.3.14 In addition, other information may be needed for statistical or other special purposes. Investigators must follow national guidelines as well as those of ICAO (see ICAO's *Accident/Incident Reporting Manual*, Doc 9156) to meet such requirements.

4.3.15 Investigators must collect information which encompasses the decisions, actions and behaviour of all the people concerned with the occurrence — not only front-line operators. Investigators must also identify the conditions under which these decisions, actions and behaviour were carried out. These conditions would include the organizational structure and the policies, procedures and practices under which activities were performed. It is through such an approach that a full understanding can be gained of how the "window of opportunity" for an accident or incident was created.

### The SHEL model

4.3.16 In addition to Reason's model, the conceptual SHEL model will facilitate the data collection task by providing a systematic approach to identifying problems (see Figure 4-4 for a complete description of the SHEL model). The central human component does not act on its own; it interacts directly with each of the others. The edges of this human block are not simple and straight, so other blocks must be carefully matched to them if stress and eventual breakdown (an accident) are to be avoided. The investigation of Human Factors must identify where mismatches between components existed and contributed to the occurrence, and so the data collected during the investigation should permit a thorough examination and analysis of each of the SHEL components.

4.3.17 The following description of the components and interfaces will help investigators collect data to achieve a thorough Human Factors investigation. Where appropriate, data from the Anytown scenario are included.

### Liveware — the individual

4.3.18 The liveware component — the individual — is the centrepiece of the SHEL model. The data that

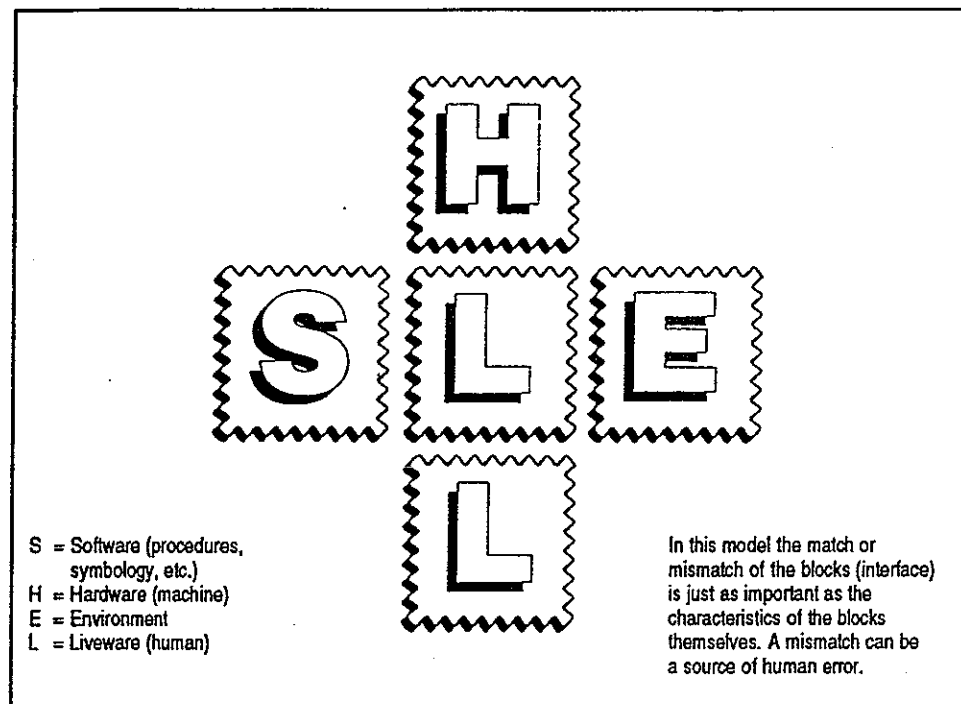

Figure 4-4. The SHEL model (adapted from Hawkins, 1975)

should be collected to address this central component can be broken down into four categories: physical, physiological, psychological and psychosocial.

**Physical factors** deal with the physical capabilities and limitations of the individual. Included are the individual's anthropometric (basic physical) attributes, physical condition, physical strength, motor skills and visual, auditory and other senses.

**Task — Determine:**

- was the individual physically capable of performing the required task?
- what physical impediments or limitations to successful performance were present? and
- how did these physical or sensory limitations create difficulties or illusions that affected the task?

*Anytown: The investigation did not disclose any evidence of physical factors that would have played a role in degrading the performance of the captain, first officer, or other operator.*

**Physiological factors** deal with the individual as a complex organism encompassing a large array of systems. Included are the individual's general health, as well as nutrition, disease, tobacco, alcohol or drug use, stress and fatigue levels, and general lifestyle considerations.

**Task — Determine:**

- was the individual physiologically fit to perform the required task?
- how did physiological fitness influence the individual's performance and judgement?
- how did the individual's ability to handle stress, fatigue or disease affect actions, behaviours and judgement? and
- was the individual affected by any type of physiological deprivation?

*Anytown: Other than the suggestion that fatigue and stress would be factors to consider, the investigation did not reveal any evidence of other physiological factors that might have adversely affected the crew's or other operators' performance.*



Psychological factors determine what individuals bring with them to work situations as a result of their acquired knowledge and experience and their mental capabilities. Included are training, knowledge, experience and planning; perceptions, information processing, attention span and workload; personality, mental and emotional state, attitudes and mood.

**Task** — Regarding training, knowledge, experience and planning, determine:

- was the individual's training, knowledge and experience sufficient, relevant and applicable to the situation?
- how did the nature and recency of the experience, training, or knowledge influence the individual's self-confidence, ability to complete the actions or perceived level of workload?

**Task** — Regarding perceptions, information processing, attention span and workload, determine:

- was there an inaccurate perception or mental representation of the task to be performed?
- did the individual suffer from any misperceptions, delayed perceptions, or illusions caused either by the visual or vestibular system or by circumstances surrounding the flight?
- did the level of attention required or the amount of information to be processed exceed the individual's own limitations?
- did the individual's ability to handle the events cause biases in judgement and change the perceived workload level?

**Task** — Regarding personality, mental and emotional state, attitudes and mood, determine:

- was the individual psychologically fit for the task?
- what do the facts indicate about the individual's attitudes towards work, others and self?
- how did these attitudes influence motivation, quality of work and judgement?
- how did personality and mental state influence the individual's approach to the situation?

- how did the individual's ability to cope with stress and to respond to emergencies influence the event sequence?

*Anytown: The evidence suggests that several areas should be examined more closely. These areas are training and knowledge, perceptions, information processing, workload and perhaps attitude. Although it was reported initially that the captain was a well-balanced individual with no personal or professional behavioural extremes, it would be useful to gather more information concerning his ability to handle the captain's higher level of responsibility. The fact that he had not yet flown with other first officers would, however, make an assessment of his performance as a captain difficult. Examination of some of these psychological factors would also apply to the first officer, the dispatcher and the Anytown agent.*

Psychosocial factors deal with the pressures brought to bear on an individual by the social system (non-work environment). Included are events and stresses (e.g. a death in the family or financial problems) as well as relationships with others (family, friends and peers).

**Task** — Determine:

- did psychosocial factors motivate or influence the individual's approach to a situation or the ability to handle stress or unforeseen events? did they contribute to the degree of fatigue experienced?

*Anytown: The investigation did not reveal any evidence of psychosocial factors having had a negative effect on the flight crew's actions. However, the Anytown company agent had been separated from his family for an extended period, a situation which had lowered his motivation.*

#### *Liveware-liveware interface*

4.3.19 The liveware-liveware interface is the relationship between the individual and any other persons in the workplace. Staff-management relationships also fall within the scope of this interface, as corporate climate and company operating pressures can significantly affect human performance. Data requirements span such subjects as human interactions, communication (verbal and non-verbal) and visual signals.

**Task** — Determine:

- did the interaction or communications with other people in the work environment influence the

performance of individuals, their attitudes, their level of stress, their perceived task demands and workload levels?

- did verbal and non-verbal communication, or the lack thereof, influence the sequence of actions in an inappropriate or irreversible manner?
- did visual signals replace, support or contradict oral information?
- how would you evaluate the crew's interactions and compatibility in terms of personality, experience level and working habits?
- how did the crew work together; how did they make use of their resources?
- did management policies regarding personnel issues affect working conditions, experience and knowledge level of employees?
- were policies and standards existing, available, current and adequately implemented, accepted, monitored or supervised?
- how did the supervisor-employee ratio influence the operation?
- what was the union's influence on policies, workers and management?
- what kind of operational environment did management promote, and how did it affect employees' decision-making and choice of actions?

*Anytown: There is ample evidence that the liveware-liveware interfaces should be explored, starting with those between the flight crew, the captain and the dispatcher, and between the dispatcher and the company agent in Anytown. Additional interrelationships to be examined include personnel in the training department, the company's check pilots and line management in the training and operations departments.*

#### **Liveware-hardware interface**

4.3.20 The liveware-hardware interface represents the relationship between the human and the machine. Data requirements span such subjects as cockpit and workstation configuration, display and control design, and seat design and configuration.

**Task — Determine:**

- how did interactions between the individual and the equipment influence information-processing capabilities?
- how did design or layout influence response time, action sequencing, habit patterns, workload or orientation?

*Anytown: There are some physical features of the aircraft which could have been factors in the accident. Activation of its alternate braking system requires abnormal body movements. Deployment of the ground spoilers requires using handles on the thrust levers which are similar to thrust reverser handles. In addition, it is known that, because of its lower-pressure tires, this aircraft is more prone to hydroplaning than are the other types on which the captain was more experienced.)*

#### **Liveware-software interface**

4.3.21 The liveware-software interface reflects the relationship between the individual and supporting systems found in the workplace. Data requirements span such subjects as regulations, manuals, checklists, publications, standard operating procedures and computer software design.

**Task — Determine:**

- were manuals, checklists, maps, or any written documents readily available? adequate? used?
- were the format, content and vocabulary used consistent from one document to another? were they easy to understand and use, logical and appropriate?
- how did written or computerized information induce errors, influence response time or generate confusion?
- how did computer displays and keyboard compatibility cause confusion, influence response time or hide blatant errors?
- how did automation affect the individual's actions and workload, work conditions, attitudes towards work and mental representation of the task?

*Anytown: The evidence points to several potential problems regarding the adequacy of training material,*

*quick-reference data pertaining to the landing performance of the aircraft on contaminated runways, training information, manuals and checklists for dispatchers and agents, etc.*

#### **Liveware-environment interface**

4.3.22 The liveware-environment interface is the relationship between the individual and the internal and external environments. The internal environment is that of the immediate work area, including temperature, ambient light, noise and air quality. The external environment includes both the physical environment outside the immediate work area as well as the broad political and economic constraints under which the aviation system operates. Data requirements include weather, terrain and physical facilities, infrastructure and economic situation.

#### **Task — Determine:**

- were there any environmental factors which might have led the individual to take shortcuts or make biased decisions or which might have created illusions by affecting vestibular, visual or auditory perceptions?
- were there any indications that the weather or dispatch, hangar, gate, or aerodrome infrastructure caused delays leading to shortcuts, reduced safety margins or limitations on the individual's choice of actions?
- were there economic or regulatory pressures which biased decision-making?

*Anytown: There is evidence that the external environment in which the flight crew were operating could have contributed to visual illusions during the instrument approach. Weather conditions played a role in the captain's decision to delay the flight and degraded the stopping performance of the airplane. Also, the runway layout and condition was conducive to standing water. There were problems with dispatch and there was probably induced pressure on the captain to land at the airport on the first approach because he had delayed the flight schedule substantially. This latter factor should also be taken into account under physiological factors (potential stress).*

#### **How much information is enough?**

4.3.23 In conducting the investigation of Human Factors, the question "how much data is enough?"

frequently arises. How many peers, relatives and supervisors of the pilot should be interviewed? How far back in time should personal activities be investigated? To what extent should interpersonal relationships (including spousal) be examined? At what point does past behaviour cease to influence current behaviour? How high in management should the investigation progress?

4.3.24 In dealing with Human Factors issues, the dividing line between relevancy and irrelevancy is often blurred. Data that initially may seem to be unrelated to the occurrence, could prove to be extremely relevant after relationships between particular events or elements have been established. Clearly, good judgement is necessary in order to determine the relevancy of information obtained during the investigation.

4.3.25 It has often been said that accident investigators only gather facts during the course of their investigation and do not analyse until all the facts, conditions and circumstances of the accident have been obtained. While this may appear to be an objective approach to an investigation, it is not realistic. "Actually, nothing is more detrimental to the field phase of an investigation than the pretence that all pertinent facts can be discovered without a selective, analytical process."<sup>3</sup> Although a standardized methodology has not been adopted, investigators have recognized the necessity for some form of ongoing reasoning process.

4.3.26 G.M. Bruggink describes the analytical reasoning process as theorizing — "to arrive by reasoning at possible explanations of known or suspected accident facts." He states that the reasoning process forms the basis for the development and integration of promising avenues of investigation, and suggests that the level of confidence placed on these explanations will depend on the weight of the available evidence.<sup>4</sup>

4.3.27 Clearly, there is a limit to how far the investigation of Human Factors can or should go. Pursuit of these aspects of the investigation in the interests of academic research is not the purpose of the investigation and may be counterproductive. Investigators should also remember that it is not necessary for the facts, analysis and conclusions of investigators to stand the test of a court of law, for this is the purpose of judicial inquiry and not accident prevention. The available investigative resources must also be considered when determining the depth and detail of information to be collected. Resource limitations may mean that investigative efforts may concentrate on only the principal individuals, and that fewer data may be collected on the more peripheral individuals involved in an occurrence.

4.3.28 Finally, in determining the depth and detail of information to collect, the purpose of investigating Human Factors must not be forgotten. The task is to explain how the causal event sequence was initiated and why it was not interrupted before the mishap — WHY, not who was to blame. If the data does not help to explain these questions, then it is not relevant.

#### Use of checklists

4.3.29 Checklists are not strict protocols for the rigid step-by-step conduct of an investigation of Human Factors, but are instead useful aids in organizing and conducting the investigation of Human Factors. They can help verify the thoroughness of the investigation of the relevant Human Factors issues, and assist the investigator to organize and prioritize the gathering of evidence. However, since most occurrences are by nature unique and diverse, investigators must be flexible in their use of checklists.

4.3.30 Numerous checklists have been prepared by different investigation organizations. Three examples are shown in Appendix I: the first example was designed to assist investigators in focusing investigation and analysis on the most relevant areas; the second example provides a more detailed breakdown of information to be collected, based on the SHEL model; the third example was designed to assist investigators in developing an understanding of the personnel selection, training and experience issues relevant to the occurrence under investigation.

#### Information sources

4.3.31 Information relevant to an aviation occurrence can be acquired from a variety of sources. Primary sources relating specifically to Human Factors include hardware evidence, paper documentation, audio and flight recorder tapes and interviews, direct observation of aviation personnel activities and simulations. Secondary sources include aviation occurrence data bases, reference literature and Human Factors professionals and specialists.

##### *Primary sources*

4.3.32 Hardware evidence is most often associated with the aircraft but may also involve other work stations and equipment used by aviation personnel (eg. air traffic controllers, aircraft maintenance and servicing personnel). Specific sources include aircraft wreckage, similarly configured aircraft, manufacturer's data, company records and logs, maintenance and servicing equipment, air traffic control facilities and equipment, etc.

4.3.33 Paper documentation spans the complete spectrum of SHEL interfaces. Specific sources include: personal records and logbooks; certificates and licenses; company personnel and training records; aircraft flight manuals; company manuals and standard operating procedures; training manuals and syllabi; company training and operational schedules; regulatory authority records; weather forecasts, records and briefing material; flight planning documents; medical records; medical and post-mortem examinations (see the *ICAO Manual of Civil Aviation Medicine*, Doc 8984).

4.3.34 Flight data recordings and ATC radar tapes are invaluable sources of information for determining the sequence of events and examining the liveware-liveware and liveware-hardware interfaces. Within airlines using flight recorder monitoring programmes, there can be a wealth of information about crews' normal operating procedures. In addition to traditional flight data recordings, new-generation aircraft have maintenance recorders and some electronic components with non-volatile memories that are also potential sources of pertinent information. Audio (ATC and CVR) recordings are invaluable sources of information about the liveware-liveware and liveware-hardware interfaces. In addition to preserving personnel communications, audio recordings can also provide evidence on the state of mind of individuals, and possible stress or fatigue. It is essential, therefore, that persons familiar with the crew listen to the recordings to confirm the identity of the speaker (if hot microphones are not used) and to indicate any anomalies in speech pattern or style.

4.3.35 Interviews conducted with individuals both directly and indirectly involved in the occurrence are also important. Examples of individuals from whom interviews may be required are:

- survivors (flight and cabin crew or passengers), next of kin, neighbours, friends, colleagues, air traffic controllers, eyewitnesses
- ground handlers, dispatchers, weather briefers, aircraft maintenance engineers, baggage handlers, de-icing personnel
- company owner, chief of flight operations, chief pilot, chief instructor, check-pilot, supervisor, former employers, training captains
- chief of maintenance, maintenance engineers, technical specialists, regulatory authorities
- family or personal physician, psychologist, aeromedical examiner.

Knowledge gleaned from such interviews can be used to confirm, clarify or supplement data from other sources. In the absence of measurable data, interviews become the single source of information, and investigators therefore need to be skilled in interviewing techniques. Guidelines on interview techniques are contained in Appendix 2 to this chapter.

4.3.36 Direct observation of actions performed by aviation personnel in the real environment can reveal important information about Human Factors. Observations can be made of flight operations activities, flight training activities, maintenance activities and air traffic control activities.

4.3.37 Simulations permit reconstruction of the occurrence and can facilitate a better understanding of the sequence of events which led up to it, and of the context within which personnel perceived the events. Computer simulations can be used to reconstruct events by using data from flight recorders, air traffic control tapes and other physical evidence. Often a session in an aircraft flight simulator or reconstruction of a flight in a similar aircraft can offer valuable insights.

#### *Secondary sources*

4.3.38 Not all Human Factors factual information is gathered in the field. After the field phase of the investigation, additional information about Human Factors may be collected, facilitating analysis of the factual information collected in the field. These empirical data come from several sources.

4.3.39 Aviation safety databases containing accident/incident data or confidential reporting systems and data bases maintained by some aircraft manufacturers are useful sources of information directly related to the aviation operational environment. Examples are: ADREP (ICAO), SIE/IATA, SECURITAS (Canada), ASRS (United States), CAIR (Australia), CHIRP (United Kingdom).

4.3.40 Investigators should use *database information* with caution, however, being sure to know its source and target population, as well as its limitations. They should be familiar with the vocabulary used in a specific database, as no single set of key words is common to all databases. Coding and data entry criteria differ between various databases, which may affect the meaning of retrieved data. See Appendix 4 to this chapter for a more detailed discussion of databases and their application to the investigation of Human Factors.

4.3.41 Basic psychological and sociological references can be good sources of information about general human performance, but they seldom address human behaviour in conditions comparable to the aviation operational environment. In recent years, professionals in the Human Factors field have provided some valuable material addressing aviation operational issues, a number of relevant reference documents are listed at the end of this manual. Some aviation research agencies will, on request, provide literature review services on selected topics. Additional references can be found in Part I, Chapter 1 of this manual.

4.3.42 At any time during an investigation, investigators must be willing to consult professionals outside their area of expertise. These professionals include, but are not restricted to:

- medical officers — to analyse the impact of any medical condition found in the flight crew or other relevant personnel;
- psychologists — to help analyse the impact of environmental, operational and situational factors on motivation and behaviour;
- sociologists — to help evaluate the factors that affect interactions and performance;
- sleep researchers and professionals — to evaluate the quality of rest available to the individual, and the impact on performance of a particular work-rest duty cycle or of circadian factors; and
- ergonomists — to assess the effect of design and layout on the user.

#### **Analysis of data**

4.3.43 Having completed the task of collecting the Human Factors information pertaining to an occurrence, the investigator is faced with the challenge of analysing the data. For the most part, investigators have been quite successful in analysing *measurable* data as it pertains to Human Factors — for example, the strength required to move a control column, lighting needed to read a display, temperature and pressure requirements, etc. Unfortunately, many of the more critical Human Factors do not lend themselves to simple measurement and are thus not entirely predictable. As a result, much Human Factors information does not allow an investigator to draw indisputable conclusions.

4.3.44 The logic necessary to analyse less tangible phenomena necessarily differs from that required in other areas of the investigation. It has been argued that, traditionally, investigators are comfortable using deductive argument which produces “conclusive evidence of the truth ...”, because their conclusions are self-evident.<sup>5</sup> When the validity of the conclusions cannot be tested conclusively, and they must deal instead with analysis based on probabilities and likelihoods, investigators become cautious and reluctant. Caution may be commendable, but investigators must adopt strategies for overcoming reluctance.

4.3.45 Several other identified problems which investigators must consider when analysing Human Factors information are:

- how to assess relevancy of certain behaviour or actions deemed abnormal or non-standard;
- how to weigh sensitivity and privacy considerations;
- how to avoid speculation.

4.3.46 Deductive methods are relatively easy to present and lead to convincing conclusions. For example, a measured windshear produced a calculated aircraft performance loss, leading to the conclusion that the windshear had exceeded the aircraft performance capability. In another example, the engine failed because the turbine blade failed, because of metal fatigue which was not detected during inspection, because the inspection procedure was inadequate.

4.3.47 Such straight-line cause and effect relationships may not be easily established with Human Factors issues, such as complacency, fatigue or distraction. For the purposes of this discussion, these aspects are referred to as “intangible” human performance factors, as opposed to readily measurable Human Factors such as hearing, eyesight, heart attack, drug or alcohol impairment, etc.

4.3.48 For example, if an investigation revealed that a pilot made an error leading to an accident, and if conditions conducive to fatigue, or a distracting conversation, or evidence of complacency were present, it does not necessarily follow that the error was made because of these conditions. There will inevitably be some degree of speculation involved in arriving at the conclusions, and their viability is only as good as the reasoning process used by the investigator and the weight of evidence available.

4.3.49 Because it involves probabilities and likelihoods, inductive reasoning is less precise than deductive reasoning. (In this context, “probability” is not meant to imply the precision of mathematical probability; instead, it is used in the way a lay speaker might state some conclusion as being certain, probable, possible or unknown). Inferences are drawn on the most probable or most likely explanations of behavioural events, and a conclusion reached by inductive reasoning cannot be tested conclusively. Inductive conclusions can be challenged, depending on the weight of evidence supporting them. Accordingly, they must be based upon a consistent and accepted reasoning method.

4.3.50 To ensure that all reasonable possibilities are considered while at the same time reducing the investigator’s task to manageable levels, the Australian Bureau of Air Safety Investigation has successfully applied the following similar step-by-step reasoning process to deal with the less tangible Human Factors evidence. In the following discussion, “empirical knowledge” refers to experimental findings which have gained general acceptance within the Human Factors research community. It is assumed that the investigator has a sound basic knowledge of Human Factors, and that the evidence gathered in the investigation is complete. Following the description of each step is a brief illustration from the Anytown accident.

#### *Step 1: test for existence*

4.3.51 The first step in the process is aimed at establishing the probability of the existence of some Human Factors condition.

- Considering all of the evidence available, establish what Human Factors issues should be considered.

*Anytown: After applying a checklist, the investigator decided that there was at least some evidence of 17 different Human Factors issues, such as: fatigue, misinterpretation of visual cues, inadequate information flow, training deficiencies, scheduling pressure, confusing control layout, cockpit lighting, stress, distractions, etc.*

- Weighing the relative importance of all of these possibilities, determine those issues that should be examined in detail.

*Anytown: After examining the 17 possible factors, the investigator decided that some, such as cockpit lighting, were not important. There remained 9 issues requiring examination in detail.*

- Establish what is empirically known about each of these issues and the underlying causes.

*Anytown: The investigator reviewed Human Factors reference material to confirm what is known about the 9 key issues; a human performance specialist provided advice on visual illusions.*

- Compare the circumstances of the occurrence against the empirical knowledge.

*Anytown: Evidence pertaining to the 9 key issues was compared to the corresponding reference material.*

- Determine the probability that one or more of these Human Factors conditions existed.

*Anytown: Visual illusion was determined to be highly probable as a factor in the accident because of the conditions that existed and the flight path of the aircraft.*

#### Step 2: test for influence

4.3.52 The second step is aimed at establishing the probability that a particular Human Factors condition influenced the sequence of events leading to an occurrence.

- Examine what is empirically known about the effects of the Human Factors conditions determined in Step 1 to exist.

*Anytown: The visual illusion which the pilot was probably experiencing (black hole) has been studied extensively and is known to cause a characteristic approach path.*

- Compare the actions and performance of the people involved in the occurrence against the empirical knowledge.

*Anytown: The initial approach path recorded on the flight data recorder closely matched the typical black hole approach path. Cockpit voice recorder evidence showed that the crew believed that the approach path was accurate.*

- Determine the probability that the actions and performance of personnel were affected by the Human Factors conditions which existed.

*Anytown: "At the time of the occurrence, the pilot-in-command probably experienced a visual illusion induced by the absence of visual cues on the night approach." Note the use of qualifying probability language. It was concluded that the captain misjudged the initial approach path because of the illusion.*

- Determine the probability that the condition did contribute to the sequence of events leading to the occurrence.

*Anytown: Late in the approach the crew detected that they were below the desired approach path. In their attempts to re-establish a safe approach path they built up excessive airspeed, which contributed to the overrun. "It is probable that the visual illusion contributed to the pilot's misjudgement of the approach path."*

#### Step 3: test for validity

4.3.53 The steps outlined above rely on an accumulation of evidence which may not allow indisputable conclusions to be drawn, but which will often allow conclusions of probability. In some ways the use of conclusions of probability is similar to the legal profession's use of circumstantial evidence, requiring the development and testing of hypotheses. The strength of this approach is that it forces the investigator to draw conclusions in a systematic way on the basis of empirical knowledge and verifiable evidence from which there are no indisputable conclusions, and ensures that the investigator considers all likely factors.

4.3.54 The analysis of Human Factors must take into account the accident prevention objective of the investigation. It has been established that occurrences are seldom the result of a single cause. Thus, if the accident prevention aim of an investigation is to be achieved, the Human Factors analysis must acknowledge that although individual factors may seem insignificant when viewed in isolation, they can produce a sequence of unrelated events that combine to produce an accident. The view of an interactive aviation industry system suggested by James Reason provides an excellent framework from which investigators can achieve a thorough analysis of Human Factors at all levels. The Human Factors analysis must not focus on the active failures of front-line operators alone but must include an analysis of the fallible decisions at all levels which interacted to create the "window of opportunity" for an accident to occur.

## 4.4 REPORTING AND PREVENTIVE ACTION

### General

4.4.1 Having completed the gathering and analysis of the relevant facts, the investigator must prepare the report of the investigation. This chapter discusses report writing in general, with emphasis on Human Factors issues, and provides the investigator with a method for reporting which expands upon guidance contained in the *ICAO Manual of Aircraft Accident Investigation*.

4.4.2 Prior to writing the report, the investigator should consider who will read it. Accident/incident reports attract a varied readership, and each reader looks at the report from a different perspective. Industry readers will read the report to ensure that it is technically correct; those who were directly involved in the occurrence will be concerned with their own accountability; the travelling public will want to be assured that problems have been identified and are being dealt with; the media will want to extract the more sensational elements; and litigants will be looking for who is liable. In writing the report, the investigator should be sensitive to the different motivations, striving for technical accuracy, but ensuring that the language used can be understood by the layperson and that statements of blame or liability are avoided.

4.4.3 Most importantly, the investigator must keep in mind the fundamental purpose of the investigation: the prevention of accidents and incidents. So, in addition to reporting the causes of an occurrence, the report should serve as a means to identify the hazards uncovered during the course of the investigation and whether they were handled effectively or ineffectively by the operator and regulator. Also, the report must offer recommendations that aim at either eliminating or controlling those hazards. The report also serves as a tool to educate the aviation community — to be effective, it should be written so that the reader, be it pilot, mechanic, manager or regulator, can recognize and relate to the hazards reported and adopt appropriate preventive strategies.

4.4.4 The investigator should also understand that the most important reader is the person responsible for the implementation of the report's safety recommendations. If that person is not convinced by the report, preventive actions will not likely be taken.

4.4.5 Richard Wood, in discussing aircraft accident report writing at an International Society of Air Safety Investigators (ISASI) conference in Munich in 1989, stated that "everyone who participated in the investigation

understands the accident — or they think they do — but the written report is going to be the basis for prevention, not the investigator's recollections. If the report is not adequate, it really doesn't make any difference how good the investigation was."<sup>6</sup> He further points out that a poor report can undermine a good investigation because the decision-makers are not going to react to a report that is flawed or poorly substantiated. When writing an accident report, investigators should consider the following statement taken from the *ICAO Manual of Aircraft Accident Investigation*:

It is ... most important that the "Final Report" is complete and accurate, not only for the sake of proper recording, but also because prevention studies can only be of value if they are based on complete and accurate information.

### Structure of the report

4.4.6 Once the Whats and Whys of the occurrence have been determined, it is relatively easy to prepare the report. Report writing is not a blind voyage of discovery wherein one writes down everything one knows about the occurrence in the hope that, by the time the end of the report is reached, the facts will speak for themselves and the conclusions will logically flow from the text. To write a good report, the investigator must acquaint the readers with the facts, conditions, and circumstances of the occurrence in an orderly fashion, and analyse the information so that the conclusions and recommendations can be understood. To do this successfully, the investigator, like any technical writer, will have to prepare a detailed outline before starting to write, and will probably want to work through several drafts to achieve a good result.

4.4.7 The investigator preparing the final report must be guided by the format in the appendix to Annex 13: Section 1 — Factual Information; Section 2 — Analysis; Section 3 — Conclusions and Causes; and Section 4 — Safety Recommendations, as described below.

4.4.8 In Section 1 — **Factual Information**, the investigator describes What happened and includes information pertinent to the understanding of the circumstances surrounding the occurrence. There are 18 subsections that give the writer sufficient flexibility to structure the flow of pertinent information. The subsections should be thought of as an organizational tool that allows the information gathered during an investigation to be arranged in a logical manner and to be included in various sections. To be included in Section 1, the information should a) provide an understanding of how



the occurrence happened; b) present in general terms the role of operational personnel involved and their qualifications; and c) provide the facts and background of hazards identified, both related and unrelated to the causes of the occurrence.

4.4.9 Human Factors information and issues should appear in most of the subsections of Section 1, set down in the standard format as appropriate. Thus:

- the sequence of events and actions of the crew, front-line operators, ATC personnel, ground crew, etc, as far as can be constructed, are described in subsection 1.1 — *History of the Flight*. This subsection is intentionally limited in scope in order to quickly orient the reader to the circumstances.
- experience, training, qualifications, duty and rest periods of the crew are included in subsection 1.5 — *Personnel Information*. Information about operational personnel who had significant roles in the occurrence, be they maintenance staff, supervisory staff, management, or regulatory personnel, should also be included in this subsection with appropriate sub-titles.
- aircraft design, certification, airworthiness, maintenance and mass and balance issues that may have had an impact on the operation of the aircraft are described in subsection 1.6 — *Aircraft Information*.
- communications, nav aids, weather, pathological issues, etc. — all elements that may have an impact on the crew's ability to operate safely — are covered under specific subsections.
- pertinent information concerning the organizations and their management involved in influencing the operation of the aircraft, including organizational structure and functions, resources, economic status, management policies and practices and regulatory framework — *organizational and management information*.
- subsection 1.18 — *Additional Information* — provides a place to include information that cannot be readily included in any of the previous subsections. It is suggested that the investigator structure this section so that a subsection 1.18.1 can present factual information in a format similar to the SHELL model. All the interfaces with the central Liveware component can be discussed in

this subsection. For instance, using the Anytown example, the investigator could expand on the liveware-liveware interface problems which surfaced in the interactions between the captain and first officer, under an appropriate heading such as "Crew Co-ordination". This is also the appropriate subsection for a discussion of a liveware-hardware limitation such as the suitability of the aircraft type for the operation and the attendant demands placed on a flight crew. Problems with written information (for example, the lack of standard operating procedures) can be addressed in the context of a liveware-software limitation. The investigator can also deal with liveware-environment limitations, such as management's decisions with respect to crew selection, pairing, standardization and training, scheduling, etc. Regulatory issues can be addressed, such as the lack of an adequate monitoring process within the regulatory agency for certifying new routes. If the investigator uses the SHELL model as a tool to aid in the gathering of information during the investigation phase, the writing of this section becomes an extension of that process.

As discussed in section 2 of this chapter, the investigator needs to present the empirical evidence to support the analysis of those Human Factors deemed influential in the occurrence. A subsection 1.18.2 can provide the appropriate place for additional information of this nature. For instance, using the Anytown example, the investigator would discuss the empirical evidence pertinent to visual illusions.

4.4.10 In all parts of section 1, only facts and factual discrepancies and hazards should be identified. One way to show the presence of a discrepancy is to compare the known events to a recognized aviation standard; for example, a discrepancy in the Anytown occurrence was the fact that the pilot, on landing, did not conform to the recommended technique to avoid hydroplaning. The hazard identified with this discrepancy was the airline company's lack of instruction or requirement to practise the proper techniques to avoid hydroplaning during simulator or flight training. Bearing in mind that many readers of the report may be unfamiliar with aviation standards and practices, it is often necessary to describe the nature of the deviation in some detail.

4.4.11 In summary, throughout section 1 of the report the deviations, discrepancies and hazards are compared to a recognized standard or with empirical evidence, thus paving the way for the analysis of their influence in bringing about the accident.

4.4.12 In section 2 — **Analysis**, the investigator can concentrate on developing the reasons why the circumstances resulted in the accident, creating the bridge between factual information and conclusions. This portion of the analysis will report the results of the Test for Existence steps for the less tangible Human Factors issues (see 2.53). Gaps in factual information must be filled in by extrapolation from the available information, by making assumptions or by the use of logic. Assumptions used in the course of the investigation must be identified in order to explain clearly the reasoning process. It is equally important to clarify what is not known and could not be determined, as well as to discuss and resolve controversial and contradictory evidence.

4.4.13 Having established all of the important factual issues making up the occurrence, the investigator must then develop the causal links. All reasonable hypotheses should be stated and evaluated to demonstrate that alternative explanations of the events have been carefully considered. For the less tangible Human Factors issues, the results of the Test for Influence steps will be reported (see 2.54). Richard Wood suggests that each subsection of the analysis should read “like a mini-accident report” wherein the facts relating to a particular issue are stated, an analysis summarizing the investigator’s opinions based on the preceding facts is provided, and conclusions about the relevance to the accident are drawn. Each portion of the analysis should “stand alone as the definitive analysis of that subject.”<sup>7</sup>

4.4.14 One way to present the analysis is to follow the order of the information presented in Part I, Appendix I. The investigator is free to choose any logical sequence to present the argument in the most effective way, however, and the sequence will often depend on the particular circumstances of the accident or incident.

4.4.15 Another effective way to present the analysis is through the use of Reason’s model as outlined in section I of this chapter. Reason’s model — like the SHELL model — is a tool, and the two go hand in hand. SHELL is a gathering tool in both the investigation and the presentation of factual information in the report, Reason’s model is an analytical framework on which the factual information can be analysed. This model fosters a systematic approach to investigation and encourages the investigator to include a description of the conditions at the time of the occurrence, line management involvement, and the fallible decisions of upper management and the regulator, followed by an analysis of each of these elements in the accident sequence. The model allows the investigator to identify the hazards that combined to create the occurrence and points the way for redress of these hazards. For example, the investigator can begin by giving

a description of the defences that were or were not in place and show how the errors committed went unchecked by the defences.

4.4.16 The use of Reason’s model can be demonstrated by the Anytown example. The writer can begin by discussing the unsafe acts committed by the captain and why the defences were unable to prevent the events from taking place:

- the captain did not follow the recommended technique to avoid hydroplaning — had he consulted the performance charts, he would have realized that the runway was not long enough for the prevailing conditions;
- the failure by airport personnel to inspect the runway for standing water eliminated one of the defences;
- when the regulators certified the airport despite inadequate firefighting equipment, they did not provide a needed defence; and
- the captain’s decision to fly the flight was made without all the available information.

These active failures are symptoms of latent failures, i.e. the decisions of upper management and the implementation of those decisions by line management. The captain’s performance is a reflection of defective policies of both the airline and the aviation administration managements — policies that included an inadequate training system, tight schedules that if delayed would collapse, the assignment of an unsuitable aircraft to the operation, and the certification of Anytown airport despite its known operational and safety deficiencies. By using Reason’s model as a framework, the investigator is able to start with the unsafe acts and show how they developed from decisions far removed in both time and space.

4.4.17 Once the causation chain has been formulated and causal hazards identified, the writer can turn to other hazards that were non-contributory but which nevertheless warrant safety action.

4.4.18 Section 3 — **Conclusions**, should flow logically from the analysis. The conclusions stated should be consistent with the analysis and all hazards should be identified appropriately. Important findings may be paraphrases or duplications of the conclusions drawn in the analysis. Investigators must be careful to use the same degrees of certainty in their conclusions as they have established in their analyses.

*Anytown: The conclusion reached in the analysis on the role of the illusion could be repeated verbatim: "It is probable that the visual illusion contributed to the pilot's misjudgement of the landing." It would be inconsistent and intellectually dishonest to remove the word "probable" and state this particular conclusion as a certainty.*

4.4.19 Sometimes the circumstances of the accident are such that no firm conclusion can be drawn about causes. Some of the more likely hypotheses should be discussed, but the investigator should have no hesitation to state that the causes remain undetermined.

4.4.20 The ICAO *Manual of Aircraft Accident Investigation* states that "The expression of causes should be a concise statement of the reasons why the accident occurred and not an abbreviated description of the circumstances of the accident." It remains a problem that many cause statements in accident reports are not really causes on which safety recommendations can be made, but rather merely brief descriptions of the accident. The expression of causes may also have other shortcomings — for example, sometimes only one or a small number of causal factors receives emphasis to the detriment of other factors which could be equally important in terms of accident prevention. Also, there is a tendency to highlight the active failures of the persons closest to the event rather than to establish a complete explanation of why the accident occurred.

4.4.21 The expression of causes should be based on the following principles:

- all causes should be listed, usually in chronological order;
- causes should be formulated with corrective and preventive measures in mind;
- they should be linked and related to appropriate safety recommendations; and
- causes should not apportion blame or liability.

4.4.22 A few States have used a format that eliminated the problems associated with the expression of cause statements by simply not making such statements. Instead, their conclusions section comprises a listing of all findings considered factors in the occurrence under the heading "cause-related findings". This is followed by a listing, under the heading "other findings", of all those hazards which did not contribute to the occurrence but which nonetheless need to be addressed.

4.4.23 The use of probability language may be called for when stating findings relating to human performance. When the weight of the evidence is such that a definitive statement cannot be made, investigators should state findings as positively as possible, using the appropriate degree of confidence and probability in their language.

#### Accident prevention

4.4.24 According to the ICAO *Accident Prevention Manual*, accident prevention must aim at all hazards in the system, regardless of their origin. If we are to prevent accidents, follow-up action must be taken in response to the hazards identified in the course of accident and incident investigations. ICAO Annex 13 places considerable emphasis on such accident prevention measures. Paragraph 7.1 states that:

At any stage of the investigation of an accident or incident, wherever it occurred, the accident investigation authority of the State conducting the investigation shall recommend to the appropriate authorities, including those in other States, any preventive action which needs to be taken promptly to prevent similar occurrences.

4.4.25 Regarding Section 4 of the final report — **Safety Recommendations**, the ICAO *Manual of Aircraft Accident Investigation* states:

Include here any safety recommendation made for the purpose of accident prevention and state, if appropriate, any resultant corrective action. Irrespective of whether recommendations are included as an integral part of the report or presented separately (dependent upon State procedures), it should be borne in mind that the ultimate goal of a truly effective investigation is to improve air safety. To this end the recommendations should be made in general or specific terms in regard to matters arising from the investigation whether they be directly associated with causal factors or have been prompted by other factors in the investigation.

4.4.26 While the emphasis is on formulating recommendations, the more difficult task is clearly identifying the hazards warranting follow-up safety action. The focus of the investigator at this point must be on problem definition, as only after the problem has been clearly identified and validated can reasonable consideration be given to corrective action.

4.4.27 The Reason model, as illustrated in Figure 4-5, provides guidance in the formulation of preventive

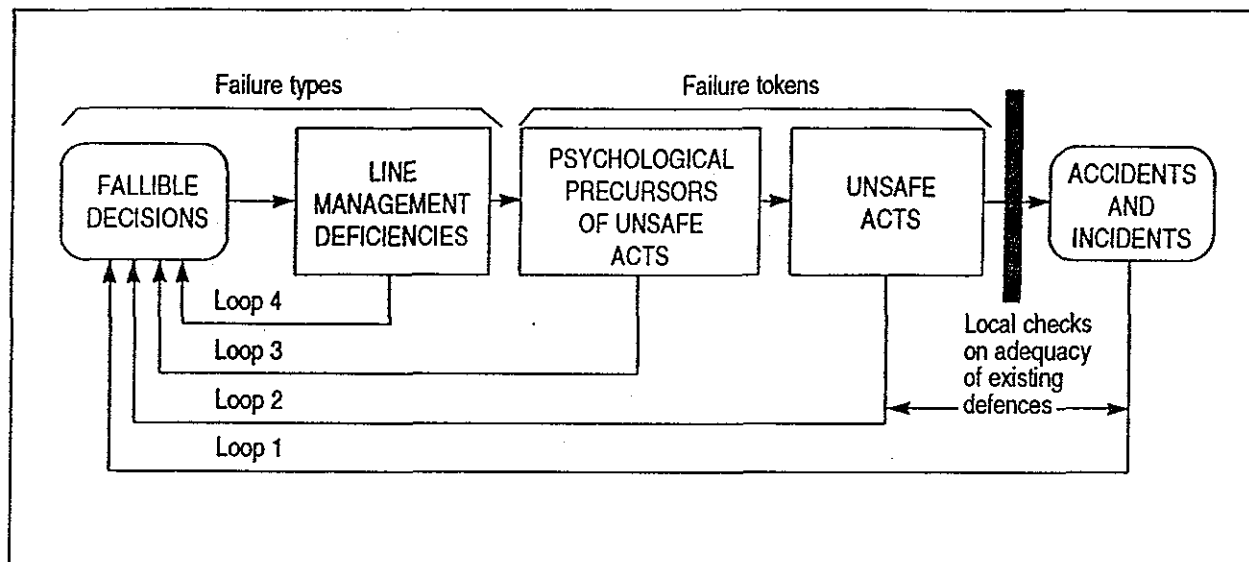

Figure 4-5. Preventive measures in accident occurrences can be paralleled to James Reason's approach to the role played by feedback loops in the control of safe operations

measures just as it provides guidance for accident investigation. Since many of the psychological precursors and unsafe acts are results of decisions made further up the line, it makes sense to concentrate preventive measures on hazards created or ignored by the higher levels of management. If the report focuses on the specific error of an individual while failing to consider higher-level decisions, it will do nothing to address the underlying responsibilities for identifying, eliminating or mitigating the effects of hazards.

4.4.28 How effective companies, manufacturers or regulators are at identifying, eliminating or mitigating hazards is dependent upon the response strategy they adopt. There is a choice of three:

- deny that there is a problem;
- repair the observed problem to prevent its recurrence; or
- reform or optimize the system as a whole.

Each strategy has its own typical set of actions. A denial strategy may involve dismissing the pilot or producing a pilot-error statement; it deals only with the unsafe act and looks no further for explanation. A repair strategy recognizes the immediate problem and attempts to rectify

it through actions such as retraining the person who committed the unsafe act or modifying dangerous items of equipment. A reform strategy admits that there are problems beyond the unsafe act level and systematic action is taken, leading to reappraisal and eventual reform of the system as a whole.

4.4.29 When companies, regulators, and accident investigators adopt a reform strategy, they turn their attention to loops 3 and 4 in Figure 4-5. Deficiencies at these higher levels — including those which had nothing to do with the accident in question — deserve greatest attention in the investigation and report-writing phase. Because the causal connection is frequently tenuous, it is often a challenge to establish that a hazardous situation was created at this level. It should also be noted decision-makers do not always receive the feedback that they need to make sound decisions — such feedback is sometimes filtered by line management, resulting in unintended consequences for the organization and its personnel.

4.4.30 The problem of identifying a causal connection between a hazard and high-level management can be overcome through a systematic investigation, the appropriate research of other similar operations and examination of safety data bases. For example, using the Anytown airport scenario, it may be determined that co-ordination between pilot and co-pilot was poor, partly

because both pilots were inexperienced on aircraft type and with the operation. Disciplining or dismissing them would do nothing to eliminate the problems of crew pairing, not only in the company but in the aviation system at large. But to establish the existence of this hazard, the investigator would probably have to allude to several other accidents where a link had been established between crew co-ordination problems and higher-level corporate decisions with respect to crew pairing. Having established a common hazard for this type of operation would then lead directly to a variety of preventive strategies for dealing with such operational hazards, strategies which could be implemented and monitored.

4.4.31 The amount of time required to validate a safety hazard varies. When dealing with clear-cut factual findings such as errors in publications, material deficiencies through design errors, etc., the validation phase may be relatively short. However, for potential safety hazards involving areas of Human Factors (e.g. the effects of fatigue on crew performance, the consequences of a company's putting pressures on pilot decision-making, etc.) validation can be time-consuming, as factual evidence is often more difficult to acquire, and the effects of their interrelationships more difficult to assess. The difficulty was illustrated by the NTSB investigation into the Fairchild Metro III accident at Bayfield, Colorado in 1988. Toxicology tests revealed traces of cocaine and cocaine metabolite in the pilot. A major human performance issue was to examine the possible effect cocaine usage had on the accident sequence. The scientific data on the behavioural effects of cocaine exposure were limited, and assessment of the effects on performance was complicated when inadequate rest and a long duty day were added to the equation. Individual differences also had to be acknowledged in determining the effects of the interrelationship of these factors. This issue is still unresolved.

4.4.32 For many human performance phenomena, the evidence from a single occurrence may be insufficient to validate a safety hazard. Hence, the investigator must evaluate the data available from similar occurrences (perhaps on a worldwide basis) to demonstrate the probable impact of a particular phenomenon on human performance in the investigation in question. A comprehensive review of the professional literature may be warranted. In extreme cases additional formal study by specialists may be justified in order to validate the existence of a hazard.

4.4.33 With a clear understanding of the problem, the investigator can formulate and assess various alternative courses of action to remedy the problem. The draft recommendation should be considered for its

technical feasibility, acceptability by the aviation community, practicality and ease of implementation. In assessing alternative courses of action, consideration must also be given to the most appropriate recipient for the recommendation.

4.4.34 Safety recommendations should not be considered as authoritative edicts by the investigating body. Since the investigator cannot be omniscient, blind obedience by the regulator in implementing recommendations could bring great harm to the industry. For example, the investigator is seldom in a good position to assess the economic feasibility of implementing a particular safety measure, and the agency receiving a safety recommendation should be given considerable latitude in choosing the most appropriate course of action. The investigating agency should be satisfied if the identified safety deficiency is adequately addressed, whether or not recommendations were specifically followed. Hence, the actual wording of recommendations should be quite general, in order to give the action agency sufficient room to manoeuvre. Richard H. Wood states it this way:<sup>8</sup>

"A well thought-out recommendation should achieve two goals:

- a) It should clearly focus attention on the problem, not on the suggested solution to it. This should eliminate the possibility that the problem will be rejected along with the recommendation; and
- b) The recommendation should be flexible enough to permit the action agency some latitude in precisely how that objective can be achieved. This is particularly important if all the salient facts are not yet available and some additional examination and testing appears necessary.

In other words, the recommendation should focus on **what** needs to be changed, rather than **how** to do it."

Richard Wood has also noted that safety recommendations can generally be classified into one of three levels:

- a **level one** safety action completely removes the offending safety hazard;
- a **level two** safety action modifies the system so as to reduce the risk of the underlying hazard; and
- a **level three** safety action accepts that the hazard can be neither eliminated nor reduced (controlled), and therefore aims at teaching people how to cope with it.

The aim should always be to eliminate safety hazards; unfortunately, when dealing with hazards deriving from Human Factors, the tendency has been to prescribe level three coping strategies.

4.4.35 Since safety hazards with respect to many Human Factors may be extremely difficult to validate, it may be wise to recommend further study of the perceived hazard by more competent authorities. In this way, the investigator can proceed with the confidence that the investigation report is not the final word on particularly difficult safety issues. Industry's recognition of the importance of crew resource management (CRM) illustrates this point. In a number of one State's accident investigation reports, the hazards resulting from the lack of effective flight deck management were identified and recommendations made. The problem was thus validated through the investigation and analysis of many accidents, and this validation led to some of the larger airlines not only recognizing there were potential problems in the cockpit, but also designing and implementing CRM courses to improve cockpit co-ordination. Other airlines, realizing the value of CRM training, then began to instruct their flight crews, using the courses developed by the larger companies, and CRM training is now widely accepted and available.

#### Data base requirements

4.4.36 As previously mentioned, seldom do the events of a single accident or incident convincingly demonstrate the presence of a fundamental safety hazard with respect to Human Factors. Usually, such hazards are only validated through the analysis of similar occurrences. For such a validation process to be effective, all relevant information from previous similar occurrences would have to be adequately recorded for future reference. Indeed, one of the many reasons why progress has been slow in initiating appropriate preventive actions for many Human Factors issues is inadequate reporting of this type of information.

4.4.37 Whether or not the Human Factors data gathered in an investigation are clearly linked to the causes of the specific occurrence, they should be recorded in a Human Factors data base to facilitate future analysis. For ICAO Contracting States, the principal data base for recording such information is ADREP, a system which records a series of factors describing *what* happened as well as a series of factors explaining *why* it happened.

4.4.38 Since human error or shortcomings in performance are usually factors in accidents, ADREP provides a sound framework for recording Human Factors data. Regarding incidents, however, ADREP contains only data from incidents which were investigated and reported to ICAO in accordance with Annex 13.

4.4.39 There are other data bases available to support the investigation of Human Factors. For example, the Aviation Safety Reporting System in the United States has compiled the data from over 100 000 voluntary reports of hazards by pilots and air traffic controllers; most of these have a human performance element. Other States with voluntary reporting systems are similarly developing specialized data bases which have a high Human Factors content. Universities and research organizations also compile highly specialized data bases for analysing particular Human Factors phenomena within the context of their research efforts. While such data bases may provide a useful adjunct to the investigator in analysing a particular occurrence, they are not suitable repositories for the data arising out of the investigation — only ADREP satisfactorily provides a comprehensive world-wide means of recording accident/incident data to facilitate a better understanding of the explanatory factors.

4.4.40 On a world-wide basis, there is a continuing requirement to provide better means of recording Human Factors data in a user-friendly format if we are to learn from the lessons of others. Given the frequency of Human Factors elements in accidents and incidents, it is imperative that we facilitate future safety analysis through better data reporting.

## Appendix 1 to Chapter 4

# HUMAN FACTORS CHECKLISTS

The sample checklists which form this Appendix are based on checklists used by three different ICAO States. Although each checklist reflects a different approach to the investigation of Human Factors, all three have the goal of assisting the investigator to identify the relevant factors and focus analysis on germane issues. Any one, or even all three, may be adapted for use by the investigator.

### CHECKLIST A

To determine the relevant areas warranting further Human Factors investigation/analysis, rate the importance of each factor by indicating the appropriate weighting value beside each item.

- 0 = Not contributory
- 1 = Possibly contributory
- 2 = Probably contributory
- 3 = Evidence of hazard

- Q. Personality, moods, character \_\_\_\_\_
- R. Memory mindset (expectancy) \_\_\_\_\_
- S. Habit patterns \_\_\_\_\_
- T. Perceptions or illusions \_\_\_\_\_
- U. Bush pilot syndrome \_\_\_\_\_

### BEHAVIOURAL FACTORS

- A. Faulty planning (pre-flight, in-flight) \_\_\_\_\_
- B. Haste (hurried departure, etc.) \_\_\_\_\_
- C. Pressing the weather \_\_\_\_\_
- D. boredom, inattention, distraction \_\_\_\_\_
- E. Personal problems (familial, professional, financial) \_\_\_\_\_
- F. Overconfidence, excessive motivation ("get-home"itis) \_\_\_\_\_
- G. Lack of confidence \_\_\_\_\_
- H. Apprehension/panic \_\_\_\_\_
- I. Violation of flight discipline (risk-taking) \_\_\_\_\_
- J. Error in judgement \_\_\_\_\_
- K. Delay \_\_\_\_\_
- L. Complacency, lack of motivation, etc. \_\_\_\_\_
- M. Interpersonal tension \_\_\_\_\_
- N. Inadequate stress coping \_\_\_\_\_
- O. Drug abuse \_\_\_\_\_
- P. Alcohol/hangover \_\_\_\_\_

### MEDICAL FACTORS

- A. Physical attributes, conditioning and general health \_\_\_\_\_
- B. Sensory acuity (vision, hearing, smell, etc.) \_\_\_\_\_
- C. Fatigue \_\_\_\_\_
- D. Sleep deprivation \_\_\_\_\_
- E. Circadian dysrhythmia (jet lag) \_\_\_\_\_
- F. Nutritional factors (missed meals, food poisoning, etc) \_\_\_\_\_
- G. Medication(s) (self-prescribed) \_\_\_\_\_
- H. Medication(s) (doctor-prescribed) \_\_\_\_\_
- I. Drug/alcohol ingestion \_\_\_\_\_
- J. Altered consciousness \_\_\_\_\_
- K. Reaction time or temporal distortions \_\_\_\_\_
- L. Hypoxia, hyperventilation, etc. \_\_\_\_\_
- M. Disbarisms, trapped gases, etc. \_\_\_\_\_
- N. Decompression \_\_\_\_\_
- O. Motion sickness \_\_\_\_\_
- P. Disorientation, vertigo \_\_\_\_\_

- Q. Visual illusions \_\_\_\_\_
- R. Stress \_\_\_\_\_
- S. Hypothermia/hyperthermia \_\_\_\_\_
- T. Other acute illness(es) \_\_\_\_\_
- U. Pre-existing disease(s) \_\_\_\_\_

**OPERATIONAL FACTORS**

- A. Personnel selection \_\_\_\_\_
- B. Limited experience \_\_\_\_\_
- C. Inadequate transition training \_\_\_\_\_
- D. Lack of currency/proficiency \_\_\_\_\_
- E. Inadequate knowledge of A/C systems \_\_\_\_\_
- F. Inadequate knowledge of A/C life support systems \_\_\_\_\_
- G. Company policies and procedures \_\_\_\_\_
- H. Supervision \_\_\_\_\_
- I. Command and control relationships \_\_\_\_\_
- J. Company operating pressures \_\_\_\_\_
- K. Crew compatibility \_\_\_\_\_
- L. Crew training (e.g. cockpit resource management) \_\_\_\_\_
- M. Inadequate flight information (A/C manuals, flight planning, etc.) \_\_\_\_\_

**TASK-RELATED FACTORS**

- A. Tasking information (briefing, etc.) \_\_\_\_\_
- B. Task components (number, duration, etc.) \_\_\_\_\_
- C. Workload tempo \_\_\_\_\_
- D. Workload saturation \_\_\_\_\_
- E. Supervisory surveillance of operation \_\_\_\_\_
- F. Judgement and decision-making \_\_\_\_\_
- G. Situational awareness \_\_\_\_\_
- H. Distractions \_\_\_\_\_
- I. Short-term memory \_\_\_\_\_
- J. False hypotheses (vs. expectancy, habit, etc.) \_\_\_\_\_
- K. Cockpit resource management \_\_\_\_\_

**EQUIPMENT DESIGN FACTORS**

- A. Design/location of instruments, controls \_\_\_\_\_
- B. Lighting \_\_\_\_\_
- C. Workspace incompatibility \_\_\_\_\_
- D. Anthropometric incompatibility \_\_\_\_\_
- E. Confusion of controls, switches, etc. \_\_\_\_\_
- F. Misread instruments \_\_\_\_\_
- G. Visual restrictions due to structure \_\_\_\_\_
- H. Task oversaturation (complex steps) \_\_\_\_\_
- I. Inadvertent operation \_\_\_\_\_
- J. Cockpit standardization (lack of) \_\_\_\_\_
- K. Personal equipment interference \_\_\_\_\_
- L. In-flight life support equipment \_\_\_\_\_
- M. Effects of automation \_\_\_\_\_
- N. Seat design/configuration \_\_\_\_\_
- O. Aerodrome design and layout \_\_\_\_\_
- P. Conspicuity of other aircraft, vehicles etc. \_\_\_\_\_

**ENVIRONMENTAL FACTORS**

- A. Weather \_\_\_\_\_
- B. Air turbulence \_\_\_\_\_
- C. Illusions (white-out, black hole, etc.) \_\_\_\_\_
- D. Visibility restriction (glare, etc.) \_\_\_\_\_
- E. Work area lighting \_\_\_\_\_
- F. Noise \_\_\_\_\_
- G. Acceleration/deceleration forces \_\_\_\_\_
- H. Decompression \_\_\_\_\_
- I. Vibration \_\_\_\_\_
- J. Heat/cold \_\_\_\_\_
- K. Windblast \_\_\_\_\_
- L. Motion (dutch roll, snaking, etc.) \_\_\_\_\_
- M. Smoke, fumes in cockpit \_\_\_\_\_
- N. Oxygen contamination \_\_\_\_\_
- O. CO poisoning or other toxic chemicals \_\_\_\_\_



- |                        |       |   |       |
|------------------------|-------|---|-------|
| P. Radiation           | _____ | C. Communications (phraseology, rate of speech, pronunciation etc.) | _____ |
| Q. Electrical shock    | _____ | D. Working environment (lighting, noise, visibility, etc.)          | _____ |
| R. Flicker vertigo     | _____ | E. Equipment/display layout and design                              | _____ |
| S. Air Traffic Control | _____ | F. Judgement  | _____ |

**INFORMATION TRANSFER FACTORS**

- |  |       |  |       |
|--|-------|--|-------|
| A. Adequacy of written materials (availability, understandability, currency, etc.) | _____ | G. Training and currency                 | _____ |
| B. Misinterpretation of oral communications  | _____ | H. Co-ordination and back-ups            | _____ |
| C. Language barrier  | _____ | I. Supervisory presence                  | _____ |
| D. Noise interference  | _____ | J. ATC policies and operating procedures | _____ |

**Vehicle Operators**

- |                                 |       |   |       |
|---------------------------------|-------|---|-------|
| E. Disrupted oral communication | _____ | K. Selection and training                                 | _____ |
| F. Intra-crew co-ordination     | _____ | L. Working environment (noise, fatigue, visibility, etc.) | _____ |
| G. Crew/ATS communication       | _____ | M. Command and control, supervision                       | _____ |

**Aircraft Line-Servicing Personnel**

- |   |       |   |       |
|---|-------|---|-------|
| H. Timeliness/accuracy of verbal communications | _____ | N. Selection and training               | _____ |
| I. Cockpit crew non-verbal communications       | _____ | O. Availability of relevant information | _____ |
| J. Cockpit warnings, horns, chimes, etc.        | _____ | P. Operating pressures                  | _____ |
| K. Cockpit instrument displays                  | _____ | Q. Supervision                          | _____ |

**SURVIVABILITY FACTORS**

- |                        |       |   |       |
|------------------------|-------|---|-------|
| M. Ground/hand signals | _____ | A. Crashworthiness of design  | _____ |
|                        |       | B. Post-accident life support equipment (exits, chutes, life vests, ELTs, medical kits, etc.) | _____ |

**OTHER PERSONNEL FACTORS**

**Air Traffic Control**

- |   |       |                                   |       |
|---|-------|-----------------------------------|-------|
| A. Attention (vigilance, forgetfulness, etc.) | _____ | C. Command and control procedures | _____ |
| B. Fatigue vs workload                        | _____ | D. Crew training                  | _____ |
|   |       | E. Passenger briefings and demos  | _____ |

**B. CHECKLIST BASED ON THE SHEL MODEL**

**FACTORS RELATING TO THE INDIVIDUAL (LIVEWARE)**

**1. PHYSICAL FACTORS**

**Physical characteristics**

- \* height, weight, age, sex
- \* build, sitting height, functional reach, leg length, shoulder width
- \* strength, co-ordination

**Sensory limitations**

*Vision*

- \* visual threshold
- \* visual acuity (seeing details)
- \* focus time
- \* light adaptation
- \* peripheral vision
- \* speed, depth perception
- \* empty field myopia
- \* glasses, contacts

**Others**

- \* auditory threshold, understanding
- \* vestibular (ear senses)
- \* smell, touch
- \* kinaesthetic (body feelings)
- \* g-tolerances

**2. PHYSIOLOGICAL FACTORS****Nutritional factors**

- \* food intake 24 hours
- \* hours since last meal
- \* dehydration
- \* on a diet/weight loss

**Health**

- \* disease
- \* fitness
- \* pain
- \* dental conditions
- \* blood donation
- \* obesity, pregnancy
- \* stress coping (emotional/behavioral signs)
- \* smoker

**Lifestyle**

- \* friendships
- \* relations with others
- \* change in activities
- \* life habits

**Fatigue**

- \* acute (short term)
- \* chronic (long term)
- \* skill (due to task)
- \* activity level (mental/physical)

**Duty**

- \* duration of flight
- \* duty hours
- \* leave periods — activities

**Sleep**

- \* crew rest, nap duration
- \* sleep deficit, disruption
- \* circadian dysrhythmia (jet lag)

**Drugs**

- \* medication over the counter
- \* medication — prescription
- \* illicit drugs
- \* cigarettes, coffee, others

**Alcohol**

- \* impairment
- \* hangover
- \* addiction

**Incapacitation**

- \* carbon monoxide poisoning
- \* hypoxia/anoxia
- \* hyperventilation
- \* loss of consciousness
- \* motion sickness
- \* food poisoning
- \* nauseating fumes
- \* toxic fumes
- \* others

**Decompression/diving**

- \* decompression
- \* trapped gas effects
- \* underwater diving

**Illusions****Vestibular**

- \* somatogyral (vertigo)
- \* somatogravic
- \* the leans
- \* coriolis illusion
- \* elevator illusion
- \* giant hand

**Visual**

- \* black hole
- \* autokinesis
- \* horizontal misplacement
- \* circularvection
- \* linearvection
- \* landing illusions
- \* chain-link fence illusion
- \* flicker vertigo
- \* geometric perspective illusion

**3. PSYCHOLOGICAL FACTORS****Perceptions****Types**

- \* non perception
- \* misperception
- \* delayed perception

**Reaction time**

- \* to detect
- \* to make an appropriate decision
- \* to take the appropriate action

**Disorientation**

- \* situational awareness
- \* spatial
- \* visual
- \* temporal
- \* geographic (lost)

**Attention**

- \* attention span
- \* inattention (general, selective)
- \* distraction (internal, external)
- \* channelized attention
- \* fascination, fixation
- \* vigilance, boredom, monotony
- \* habit pattern interference
- \* habit pattern substitution
- \* time distortion

**Information Processing**

- \* mental capacity
- \* decision making (delayed, poor)
- \* judgment (delayed, poor)
- \* memory capacity
- \* forgetting
- \* co-ordination — timing

**Workload**

- \* task saturation
- \* underload
- \* prioritization
- \* task components

**Experience/recency**

- \* in position
- \* in aircraft type, total time
- \* on instruments
- \* on route, aerodrome
- \* night time
- \* emergency procedures

**Knowledge**

- \* competence
- \* skills/techniques
- \* airmanship
- \* procedures

**Training**

- initial
  - \* on the job
  - ground
  - flight
  - \* transition, learning transfer
  - \* recurrent
  - \* problem areas
  - \* emergency procedures

**Planning**

- pre-flight
- \* in flight

**Attitudes/moods**

- \* mood
- \* motivation
- \* habituation
- \* attitude
- \* boredom
- complacency

**Expectations**

- \* mind set/expectancy
- \* false hypothesis
- \* "get-home"itis
- \* risk-taking

**Confidence**

- \* in aircraft
- \* in equipment
- \* in self
- \* overconfidence, showing off

**Mental/emotional State**

- \* emotional state
- \* anxiety
- \* apprehension
- \* panic
- \* arousal level/reactions
- \* self-induced mental pressure/stress

**Personality**

- \* withdrawn, grouchy, inflexible
- \* hostile, sarcastic, negative
- \* aggressive, assertive, impulsive
- \* excitable, careless, immature
- risk taker, insecure, follower
- \* disorganized, late, messy
- \* anti-authoritative, resigned
- \* invulnerable, "macho"

**4. PSYCHOSOCIAL FACTORS**

- \* mental pressure
- \* interpersonal conflict
- \* personal loss
- \* financial problems
- \* significant lifestyle changes
- \* family pressure

**FACTORS RELATED TO INDIVIDUALS AND THEIR WORK****1. LIVEWARE-LIVEWARE (HUMAN-HUMAN) INTERFACE****Oral communication**

- \* noise interference
- \* misinterpretation
- \* phraseology (operational)
- \* content, rate of speech

- \* language barrier
- \* readback/hearback

**Visual signals**

- \* ground/hand signals
- \* body language

**Crew interactions**

- supervision
- \* briefings
- co-ordination
- compatibility/pairing
- \* resource management
- \* task assignment
- \* age, personality, experience

**Controllers**

- \* supervision
- \* briefing
- \* co-ordination

**Passengers**

- \* behaviour
- \* briefing
- \* knowledge of aircraft, procedures

**WORKER-MANAGEMENT****Personnel**

- \* recruitment/selection
- \* staffing requirements
- \* training policies
- \* remuneration/incentives
- \* crew pairing, scheduling
- \* seniority
- \* resource allocation
- \* operational support/control
- \* instructions/directions/orders
- \* managerial operating pressure

**Supervision**

- \* operational supervision
- quality control
- \* standards

**Labour relations**

- employee/employee-management
- \* industrial action
- \* unions/professional group

**Pressures**

- mental pressure — operational
- morale
- peer pressure

**Regulatory agency**

- \* standards
- \* regulations
- \* implementation
- audit
- inspection
- monitoring
- \* surveillance

**2. LIVEWARE-HARDWARE (HUMAN-MACHINE) INTERFACE****Equipment**

- Switches, controls, displays*
- \* instrument/controls design

- \* instrument/controls location
- \* instrument/controls movement
- \* colours, markings, illumination
- \* confusion, standardization

**Workspace**

- \* workspace layout
- \* workspace standardization
- \* communication equipment
- \* eye reference position
- \* seat design
- restrictions to movement
- \* illumination level
- \* motor workload
- \* information displays
- \* visibility restrictions
- \* alerting and warnings
- \* personal equipment interference (comfort)
- \* data link
- \* operation of instruments (finger trouble)

**3. LIVEWARE-SOFTWARE (HUMAN-SYSTEM) INTERFACE****Written information**

- \* manuals
- \* checklists
- \* publications
- \* regulations
- \* maps and charts
- \* NOTAMs
- \* standard operating procedures
- \* signage directives

**Computers**

- computer software
- user friendliness

**Automation**

- operator workload
- \* monitoring task
- \* task saturation
- \* situational awareness
- \* skill maintenance utilization

**Regulatory requirements**

- qualification — in position
- qualification — in management
- certification
- \* medical certificate
- \* licence/rating
- \* non-compliance
- \* infraction history

**4. LIVEWARE-ENVIRONMENT (HUMAN-ENVIRONMENT) INTERFACE****INTERNAL**

- \* heat, cold, humidity
- \* ambient pressure
- \* illumination, glare
- \* acceleration
- \* noise interference
- \* vibrations
- \* air quality, pollution, fumes
- \* ozone, radiations

**EXTERNAL****Weather**

- \* weather briefing, FSS facilities
- \* weather: actual and forecasts
- \* weather visibility, ceiling
- \* turbulence (wind, mechanic)
- \* whiteout

**Other factors**

- \* time of day
- \* lighting/glare
- other air traffic
- \* wind blast
- \* terrain/water features obstacles

**Infrastructure***Dispatch facilities*

- type of facilities
- \* use
- \* quality of service

*At the gate*

- APU
- \* towing equipment
- \* refuelling equipment
- \* support equipment

*Aerodrome*

- \* runway/taxiway characteristics
- \* markings, lighting, obstructions
- \* approach aids
- \* emergency equipment
- \* radar facilities
- \* ATC facilities
- \* FSS, weather facilities
- \* airfield facilities

*Maintenance*

- \* support equipment
- \* availability of parts
- \* operational standards, procedures and practices
- \* quality assurance practices
- \* servicing and inspection
- \* training
- \* documentation requirements

**CHECKLIST C — SELECTION, TRAINING AND EXPERIENCE****INTRODUCTION**

The purpose of this checklist on selection, training and experience for human factors aspects of accident investigation is to assist the investigator during the field phase in developing a comprehensive factual base on the pilot selection, training and experience issues relevant to the specific accident under investigation.

An effort has been made to present the checklist in a generic format so that investigators can apply it to any modality by substituting "air traffic controller", "mechanic", etc., for "pilot", as appropriate. However, since most accidents are by nature unique and diverse, some degree of discretion will be required to tailor the checklist to particular cases. In this way, the checklist is a dynamic tool, to be modified and updated with use over time.

**A. SELECTION**

- 1) When was the pilot selected for this position?
- 2) How was the pilot selected?
  - a) What were the required qualifications? (e.g. experience, education, training and physiological/medical requirements)
  - b) Were any examinations required? What? When taken?
  - c) What special licences were required?
  - d) Were the pilot's qualifications, references and licenses verified by his/her employer prior to selection for employment?
- 3) Was specific training on this position provided to the pilot before he was selected for it? If yes,
  - a) Describe the content of the training.
  - b) When was this training?
  - c) Who provided this training?
- 4) Was specific training on this position provided to the pilot after he was selected for it? If yes,
  - a) Describe its content.
  - b) When was this training given?
  - c) Who provided this training?
- 5) Where any problems ever noted with the pilot's performance after he assumed the duties of this position? If yes,
  - a) describe the problems.
  - b) When were these observations made?
  - c) Who made these observations?
  - d) What actions, if any, were taken to correct the problems?

**B. PILOT EXPERIENCE**

- 1) What other experience has the pilot had using this specific equipment?
- 2) What other jobs has the pilot had using other equipment in this modality?
- 3) What is the total length of time the pilot has worked in this modality?
- 4) How long has the pilot worked for this specific employer?
- 5) How long did the pilot work for his previous employers?
- 6) Was the pilot's previous experience verified by his/her current employer?
- 7) Has the pilot ever been involved in any other accidents in this modality? If yes,
  - a) Describe the circumstances.
  - b) When?
  - c) What equipment was in use?

- 8) Has the pilot ever been involved in any other accidents in other modalities? If yes,
  - a) Describe the circumstances.
  - b) When?
  - c) What equipment was in use?
- 9) Has the pilot ever complained about or reported any problems related to the use of this specific equipment? If yes,
  - a) Describe the nature of the complaints or report.
  - b) When?
  - c) Were any corrective action made? By whom? When?
  - d) Have any other similar complaints or reports ever been made? Provide details.

**C. PILOT TRAINING**

The investigator should review (requesting copies when applicable) training-related records, documents, rule books, manuals, bulletins and pilot examinations.

- 1) What training has the pilot received on the use of equipment in this modality?
  - a) Describe the training: classroom? simulator? on-the-job-training (OJT)? materials used? topics?
  - b) When did the pilot receive it?
  - c) Who were the instructors and/or supervisors?
  - d) How was the pilot's performance evaluated (e.g. check ride, on the road, simulation, paper and pencil examination)?
  - e) What was the over-all evaluation of the pilot's performance?
  - f) Were any problems noted in the pilot's performance? If yes,
    - What were they?
    - How were they noted and by whom?
    - What corrective actions were taken, if any?
- 2) Initial training vs. follow-on training using this specific equipment:
  - a) Has the pilot received training on this equipment from more than one employer? If yes,
    - Which employer provided the initial training?
    - When?
    - How much emphasis was placed on:
      - compliance with Standard Operating Procedures (SOPs)
      - compliance with rules and requirements?
      - use of performance evaluations (e.g. check rides, examinations)?

- b) How does the pilot's initial training differ from any follow-on or subsequent training in terms of the following:
- Compliance with SOPs?
  - Compliance with rules and regulations?
  - Use of performance evaluations (e.g. check rides, examinations)?
- c) Do any of these differences appear related to the mishaps?
- Did the pilot violate any SOPs he had been taught? If yes,
    - What were they?
    - When were they taught?
  - Did the pilot violate any rules or requirements he had been taught? If yes,
    - What were they?
    - When were they taught?
  - Has the pilot ever violated any rules, requirements, or SOPs before? If yes,
    - What were the circumstances?
    - What actions were taken?
  - Has the pilot received any new, recent training that may have:
    - Interfered with his knowledge and skills in using this equipment?
    - Required his use of new, different SOPs under emergency conditions?
- 3) Other training issues:
- a) Has the pilot received any recent training for:
- Transition to operation of different equipment in this modality?
  - Learning different operations of similar equipment systems?
- b) If the pilot has received any recent transition and/or differences training:
- Describe when and type.
  - Check potential interference from this training with operation of accident equipment.
- c) Is the pilot current in all areas of accident equipment operation?
- Describe areas lacking currency.
  - Describe required exams, certificates or licenses indicating full currency.
- d) Rate sufficiency of training on:
- Emergency situations.
  - Equipment malfunctions.
  - Maintenance reports, complaint procedures, logs.
  - Crew interaction and coordination skills.
  - Degraded conditions (e.g. reduced visibility, high sea state, gusty or high winds, heavy precipitation).
  - Communication procedures.
  - Physiological requirements (e.g. issues related to rest, health, nutrition and use of medication, drugs and alcohol).
- e) If simulators or training device were used for training:
- What specific training was provided in the simulator or training device?
  - What are the major similarities and/or differences between the simulator or training device and the actual equipment?
  - How recent was the training with the simulator or training device?
  - Were any problem areas noted in the pilot's performance?
- f) Did the pilot receive training specifically related to the conditions of the mishap (e.g. wind-shear, equipment, malfunction, specific type of emergency, specific weather conditions)? If yes,
- Describe when and type.
  - How did the pilot perform in training?
- g) Was the pilot providing or receiving training at the time of the mishap? If yes,
- Describe the circumstances in detail.
  - Determine the qualifications of instructor(s) and/or trainee(s) involved.
  - When did this training begin and how long had it been in progress?

## Appendix 2 to Chapter 4

# WITNESS INTERVIEWING TECHNIQUES

Interviews conducted with individuals either directly or indirectly involved in an occurrence are an important source of evidence. Information gleaned from such interviews can be used to confirm, clarify, or supplement information learned from other sources. Certainly, in the absence of measurable data, interviews become the single source of information, and investigators need to be well acquainted with the techniques required to ensure effective interviews.

Information gained in interviews will help to determine what happened. More importantly, interviews are often the only way to answer the important "why" questions which, in turn, can facilitate correct and effective safety action.

In most investigations, Human Factors will have to be assessed, and the investigator who dons the Human Factors hat will be faced with interviewing a variety of people. Included within this group are survivors (both crew and passengers), next of kin, friends, colleagues and company management/training personnel.

In preparation for interviews, investigators must remember that every witness deals with the occurrence from a different perspective. Consider the cabin crew members who survived a crash and may be suffering guilt at the fact that they survived while others died; they may be struggling with their role in the crash sequence, tormenting themselves with "What if" questions. The situation might involve flight crew members experiencing a myriad of emotions: grief where deaths are involved; pressure from company management or union representative; stress over whether their livelihood is at stake; anxiety over regulatory action; confusion about what happened, etc. Company management concerns may focus on regulatory action and litigation, and responses may be tailored accordingly.

Next of kin interviews are always difficult — imagine the emotional roller coaster experienced by the next of kin: grief and anger at the loss of a loved one; perhaps guilt; anxiety over financial concerns; confusion caused by media accounts, etc. Further consideration will have to be given to the witness who is under medication for shock or physical pain as a result of injury; such a situation will

have some bearing on how extensive the interview will be and on its validity.

The investigator has to be a chameleon, capable of adapting to various scenarios. An effective interviewer remains objective and avoids making evaluations early in the interview. Even when faced with conflicting evidence, the investigator should listen to what a witness has to relate and should suspend judgement of that information until all facts have been gathered and an assessment can be made: the pilot who has been fired may be a disgruntled employee with a desire to sully the company's reputation or he may be a credible witness with very real truths to relate.

The investigator must give special consideration to grieving next of kin, projecting the right amount of empathy without becoming sympathetic. The interview is a dynamic situation, and, to take advantage, the investigator has to be adaptable, knowing when to focus and when to back off. Before conducting an interview, the investigator should try to obtain as much information about factors such as the crash sequence (walking the site may be helpful), applicable procedures that were in effect (allows comparison to what was done in actuality), the crew (scanning pilot records will tell, for example, whether the pilot was required to wear glasses, and, during subsequent interviews, the investigator can attempt to establish if the pilot wore glasses during the flight), etc. By knowing as much as possible before the interview, the investigator has room to manoeuvre and is saved having to re-interview.

### Success of the interview

Good interviews are the result of effective planning. There are a number of preparatory issues that need to be considered before an interview is conducted:

#### *Timing of interviews*

Interviews should be conducted as soon as possible after the occurrence to prevent loss of perishable information as a result of fading memory or rationalization. Passage of

time also permits contamination of information, which occurs when witnesses confer with one another or listen to or read media accounts. If it is necessary to delay interviews, statements should be requested. These serve the dual purpose of capturing facts before natural decay, in addition to assisting the investigator in the preparation of the subsequent interview.

#### *Location*

Witnesses should be made to feel at ease, and to this end the investigator should choose a location that is quiet, reasonably comfortable, and free from interruption. If a witness wishes to smoke, the investigator should accommodate this wish. Next of kin will probably prefer to be interviewed in their own home.

#### *Approach*

Because Human Factors permeate all aspects of an accident, it is often advantageous for the investigator to conduct interviews in conjunction with investigators from other groups. This approach recognizes the requirement for cross-fertilization within an investigation and, in doing so, becomes an effective tool in gathering information. The team approach may eliminate the need to re-interview a witness and is thus a more efficient use of resources. Further, as team members, the investigators are able to later corroborate the information given. In deciding whether to use the team approach, the witness's personality and the sensitivity of information sought must be considered. In some circumstances, a private one-on-one interview will illicit much more information.

During interviews, investigators should minimize their input and instead concentrate on active listening — an investigator who is talking isn't listening. Certainly, the investigator must direct the interview and keep it moving, but, generally, the less active the interviewer, the more productive the result. By listening to what is being said, the investigator will be able to reformulate questions appropriate to the situation, note discrepancies and sudden changes in conversation, perceive innuendoes and observe a witness's gestures and behaviour.

Silence can be an effective tool during the interviewing process, and the investigator should avoid trying to fill in pauses in conversation too quickly. More often than not, people want to talk about the occurrence, about the friend, husband or wife they lost, about the wrongs they believe should be righted, etc., and they will often fill in the pauses themselves.

#### *Co-operation*

Co-operation, which is essential to the success of the interview, is often determined by the impression the

investigator makes on the person being interviewed. A friendly approach that treats the witness as an equal and is as unobtrusive as possible is preferable to one that is effusive or bureaucratic. Simple things, such as assessing the audience and dressing accordingly, may make a difference in how forthcoming a witness is with information. Casual clothes instead of a suit may be more appropriate and less threatening in some environments. By developing a relationship of mutual confidence with a witness, the investigator is more assured of a free flow of information, ideas and opinions. According to the ICAO *Manual of Aircraft Accident Investigation*, "a philosophy of interview rather than interrogation is desirable in the questioning of witnesses by the investigator."

#### *Control*

It is imperative that the investigator control the interview. Under certain circumstances, a witness may wish to be accompanied by another person for support — a parent may wish to be present during the interview of a child, survivors may wish to have their spouse present, a crew member may want a lawyer or union representative in attendance — and this request should be accommodated. Control becomes a difficult task when third parties are present, but an early understanding of the ground rules as specified by the investigator should minimize disruptions. Before an interview begins, it should be clear to and agreed upon by all parties that the attendance of a third party, other than an expert assisting the investigator, will only be considered at the request of the witness; that the investigator is the only person to direct questions to the witness; that questions provided in writing by other parties in attendance may be given to the investigator and, if accepted, will be used at an appropriate time; and that the investigator maintains the right to prohibit certain individuals from attending when their attendance could inhibit an effective interview.

#### *Tape recorder*

A tape recorder is a valuable tool. It allows the investigator to focus full attention on what the witness has to say; it provides a complete and accurate record of what was said; and it allows the statement to be played back. The investigator should be prepared for witnesses who are reluctant to have their statements recorded. In such cases, it will be necessary to explain that the tape recorder is there to allow the interview to be conducted more quickly and to ensure accuracy; the fact that the tape recorder provides a good record and eliminates the need to possibly re-interview a witness may be used as an argument in defence of its use. Reluctance disappears quickly if the recorder is used unobtrusively. Where there is reason to believe that the reluctance will not dissipate, the



investigator will have to use a different method, such as note-taking; those who subscribe to the team approach will be able to use this method best — one member asks questions and another takes notes.

### Structure

Effective interviews are characterized by a logical structure designed to maximize the quality and quantity of relevant information. The interview comprises four basic parts — the plan, the opening, the main body, and the closing — each with a specific purpose. In cases where there are a large number of survivors, a list of questions to be asked of every survivor should be prepared so that a comparison for reliability can be made at a later date.

#### *The plan*

Prior to interviewing a witness, the investigator needs to define the general objectives of the interview, be aware of what some of the obstacles to achieving those objectives might be, and understand the expectations of the witness. The investigator should have some knowledge of the person being interviewed and should determine questions to be asked based on that knowledge. The sequencing of questions and the placement of the tougher questions can be considered at this step. Many witnesses, such as next-of-kin, have a legitimate requirement for information about the occurrence. The investigator should preplan the information which will be released to the witness at the appropriate moment in the interview.

Preparing a list of questions that has to be rigorously followed is not the purpose of the planning step; rather it is the time to ensure that all areas of concern will be addressed during the interview.

#### *The opening*

Most witnesses are probably being interviewed by an investigator for the first time. They will be apprehensive and may have misgivings about the interview and its end result. It is important, therefore, to eliminate as much of their uncertainty as possible. To do so, the investigator should give each witness a good explanation of the investigator's role, the witness's role and rights (including advising the witness who will have access to the transcript), the purpose of the interview, and the interview process. Witnesses should be made aware that their participation is important in the determination of cause and the prevention of a recurrence.

#### *The main body*

The right question asked in the right way at the right time is a powerful tool; it focuses on the important information;

it terminates unproductive conversation; it helps people to concentrate their thoughts; and it allows the interview to flow smoothly.

Often the easiest and most effective way to begin an interview is with a free recall type question, wherein witnesses are allowed to tell their story without interruption. The investigator should be attentive to what is being said and should refrain from any gestures or mannerisms that may lead witnesses. This approach is non-threatening, it allows witnesses to believe that what they have to say is important, it begins to establish a rapport between the investigator and the witness, and it gives the investigator a baseline of uncontaminated information.

When it is apparent that a witness has nothing further to say, the investigator can begin to question in more detail. However, there is no need to change the approach — the investigator can begin the questioning for each specific topic with a general question, becoming more specific as the witness becomes more specific with the answers. By getting witnesses to co-operate in a general way, the investigator increases the likelihood that they will subsequently co-operate in more specific ways.

There are various types of questions, each of which will elicit a different type of response. The general or "open" question is the least leading and allows witnesses to answer in their own way and to formulate opinions as they see fit. With next of kin, a question such as "I didn't know your son; I wonder if you would tell me about him?" achieves the same result as a free recall question — witnesses begin to talk about something with which they are familiar and which is non-threatening. Often witnesses will begin to answer a question before it is fully asked; investigators can take advantage of this by using open-ended or trailing-off questions (e.g. "You said earlier that your training was ..."), which can evoke rapid and accurate descriptions of the subject matter. They also lead to more witness participation.

The open question may not produce exactly the answer expected, and it may be appropriate for the investigator to redirect witnesses by means of a supplementary question which is more specific. There is a caution, however, that should be acknowledged when asking more specific questions — the more specific the question becomes the more likely it is to lead witnesses, possibly pressuring them to remember something that they do not know or did not observe. "Was the pilot fatigued?" is leading, in that it contains a possible answer and thus contaminates the information; it would be better to ask the witness to "describe the pilot's physical condition and mental outlook toward the job recently". "How proficient was the pilot at single-engine go-arounds?" uses a "marked" word

(proficient) and effectively eliminates any neutrality that the investigator may be trying to achieve with the question. By using unmarked words and by setting the stage with a series of questions, the investigator can obtain the information without contaminating the response — “What is the policy for practising single-engine go-arounds?” followed by “When was the last time the pilot practised this procedure?” and ending with “Describe the procedure used by the pilot during the last practice session”. This approach is neutral and does not lead the witness.

The “closed” question (one evoking a “yes” or “no” response), produces limited information and should be avoided, unless specifically intended. “Did your husband talk to you about the problems he was having with the chief-pilot?” “Was the co-pilot uncomfortable about flying into that airport because she had not flown that route before?” “Did the captain and first officer have problems in working together as a crew?” are all questions that can elicit a yes or no response, and the investigator will have to try another tactic to get more complete responses. The investigator may be more successful by phrasing the questions as follows — “How did your husband feel about flying with this company?” “You mentioned that the co-pilot was not comfortable about flying into that airport, why not?” “Describe the captain and co-pilot’s working relationship”.

Occasionally, the investigator will have to ask questions which are more personal in nature and thus require an indirect approach. For example, the investigator believes that the deceased pilot was under a great deal of domestic stress because of marital problems; asking the pilot’s spouse “Was there anything that may have been upsetting your husband on the day of the accident?” or “Did you notice any change in your husband’s behaviour in the recent past?” will increase the chance of getting closer to the truth of the matter. The indirect approach in delicate situations also eliminates the possibility of bringing the interview to an abrupt end as may be the case with a more direct question such as “Were you and your husband having marital problems”?

Questions should be brief, clear, and unambiguous. They should be relevant to the information required and be presented one at a time. Jargon and terminology that may confuse or intimidate witnesses should be avoided. Some witnesses who have had difficulty recalling events benefit

from hearing the tape recording of their initial description of the occurrence. While listening to the account they suddenly recall forgotten information. Near the end of an interview, witnesses should be asked if they have any other information to add or if they have any questions.

### *The closing*

The closing is the time to summarize the key points and to verify understanding of the information obtained; to assure the witness that the interview has been valuable; to establish the availability of the witness at a future date should that be necessary; and to indicate the availability of the investigator should the witness wish to provide additional information or enquire about the progress of the investigation.

### *Assessment*

None of the information gained in an interview should be accepted at face value. Issues such as health can be verified against medical records; fatigue against work schedules; attitudes toward management, training and maintenance against interviews with family members, friends and colleagues, etc. By comparing the information gathered during interviews to information gleaned from other sources, the investigator will be able to piece together the puzzle more accurately and establish the credibility of various witnesses. Weight factoring of interview information and matrix evaluation of information obtained from several witnesses are effective methods of quantifying and qualifying that information.

In assessing the validity and significance of the information, the investigator should remember that witnesses’ portrayals of facts are influenced by personal biases — so too are the investigator’s. One example of bias is the “halo effect”, which occurs when an investigator forms a global impression (either positive or negative) of a person, based on one characteristic that biases the interviewer’s assessment of the other person’s ideas. For example, a seemingly comfortable, self-assured person may given more credibility than is warranted.

In summary, an interview is a dynamic event conducted in real time; planning, experience and responsiveness on the part of the interviewee are all keys to a successful outcome. While re-interviews are possible, there is no substitute for the effective first interview.

## Appendix 3 to Chapter 4

# EXPLANATORY HUMAN FACTORS

<i>Explanatory factors</i>		<i>Explanatory factors</i>	
<b>THE INDIVIDUAL</b>			
<b>Physical — characteristics of the individual</b>			
Physical characteristics	Size Weight Strength Age	Attention	Disorientation — geographic (lost) Disorientation — other Vertigo Illusion — visual Illusion — vestibular Attention span Inattention Distraction Channelized attention Fascination Vigilance
Sensory limitations	Sensory threshold (vision/visual) Hearing Vestibular (inner ear) Proprioception (sense receptors — muscles/joints) Smell Touch Kinaesthetic (muscle movement) “G” tolerance	Attitudes	Attention — other Motivation Attitude Habituation Boredom/monotony Complacency Mind set/expectancy False hypothesis Get-home-itis Confidence — in A/C Confidence — in equipment Confidence — self Attitudes — other
Other physical limitations			Mental capacity Decision-making Judgement Memory Forgetting Co-ordination/timing Information processing — other
<b>Physiological — the person's well-being</b>			
Health/lifestyle	Disease Fitness Diet Obesity Age Stress Smoker (heavy) Pregnancy Blood donation Other predisposing condition	Information processing	Experience — on instruments Experience — on A/C type Experience — total A/C Experience — other Recency — in position Recency — on instruments Recency — on A/C type Recency — on aerodrome/route Recency — other
Fatigue	Fatigue — acute Fatigue — chronic Fatigue — skill Fatigue — other Crew rest Sleep deficit/disruption Other sleep disorder Circadian dysrhythmia (jet lag)	Experience/recency	Competence Skill/technique Airmanship Training — initial Training — on-the-job Training — ground Training — flight Training — recurrent Planning — pre-flight Planning — in-flight
Drugs	Medication — over-the-counter Medication — prescription Drugs — illicit Other stimulants (coffee, cigarettes)	Knowledge	Emotional state Anxiety Apprehension Panic Arousal level/reactions Mental pressure — self stress
Alcohol	Alcohol — impairment Alcohol — hangover Alcohol — addiction	Training	Type — aggressive Type — assertive Type — non-assertive Type — other Task saturation Underload Situational awareness Prioritization
Incapacitation	Carbon monoxide poisoning Hypoxia/anoxia Hyperventilation Loss of consciousness Motion sickness Nauseating fumes Toxic fumes Other medical	Planning	
Decompression/diving	Decompression Trapped gas effects Underwater diving	Mental state	
Other physiological limitations		Personality	
<b>Psychological — the person's mental well-being</b>		Workload	
Perceptions/illusions	Situational awareness Disorientation — spatial Disorientation — visual Disorientation — temporal	Other psychological	

<i>Explanatory factors</i>		<i>Explanatory factors</i>	
<b>Psychosocial — the person's interaction with the non-work community</b>		<b>Human-environment (internal) — the interaction of the person with the environment in the immediate work area</b>	
Off-duty problems	Mental pressure Interpersonal conflict Personal loss Financial problems Significant lifestyle changes Culture Family pressure	Environment	Heat Cold Ambient pressure Illumination Glare Acceleration Effect of noise Noise interference Vibration Air quality Humidity Pollution/fumes Ozone Radiation Other physical working conditions
Other psychosocial limitations			
<b>THE INTERFACES BETWEEN INDIVIDUALS AND THEIR WORK</b>		<b>Human-environment (external) — the interaction of the person with the weather and the environment outside the immediate work area</b>	
<b>Between people — the interaction of the person with other persons in the workplace</b>		Weather/geography	Weather visibility Turbulence Infrastructure Time of day Lighting/glare Other air traffic Windblast Somatogravic Somatogyral
Oral communication	Misinterpretation Phraseology Language barrier Readback/hearback Other communications	Illusion	T h e l e a n s Coriolis Empty field myopia White-out Flicker vertigo Aerodrome — landing illusions Illusions — other
Visual signals	Signage Ground/hand signals Body language Data link		
Crew interactions	Crew supervision Crew briefing Crew co-ordination Crew compatibility Crew resource management Crew task assignment Crew — other behaviour		
Controllers	Controller supervision Controller briefing Controller co-ordination Controller — other		
Passengers	Passenger behaviour		
Other interaction			
<b>Human-machine — the interaction of the person with the equipment at the workstation</b>		<b>Worker-management — the interaction of the worker with the management</b>	
Equipment	Instrument/controls design Instrument/controls location Workspace layout Workspace standardization Personal comfort Motor workload Information displays Obstacles to vision Alerting and warnings Eye reference position	Personnel	Personnel recruitment Personnel staffing Personnel training Personnel policies Remuneration/incentives Personnel requirements Personnel scheduling Crew pairing Seniority Resource allocation Operational support Operational control Instructions/directions/orders Managerial operating pressure Operational supervision Quality control standards Qualification — in position Qualification — on type Certification Medical certificate Licence/rating Non-compliance Infraction history Other regulatory factors Employee/management relations Industrial action Union/professional group Mental pressure — operational Morale Peer pressure
Other interaction		Supervision	
<b>Human-system support — the interaction of the person with the supporting systems for the workplace</b>		Regulatory requirements	
Written information	Manuals Checklists Publications Regulations Maps and charts NOTAMs Standard operating procedures	Labour relations	
Computers	Computer software User-friendliness	Pressures	
Automation	Operator workload Monitoring task Task saturation Situational awareness Skill maintenance	Other human-environment interaction	
Other human-software interaction			

## **Appendix 4 to Chapter 4**

### **AVIATION ACCIDENT/INCIDENT DATA BASES**

The most useful sources of supporting factual information come from reference and data bases directly related to the aviation operational environment, because these can be most easily generalized to the factual data pertaining to an aviation accident. The data from these data bases can be used (with some caution) to answer the question "What are the frequencies of such occurrences or behaviours?" (i.e. how many accidents or incidents have involved the same performance shortcomings?). Of course, specific information about the sample characteristics of the data bases being examined, and about the exposure rates of aircraft or pilots in similar situations is necessary in order to reach any conclusions about probabilities of similar accidents or incidents occurring again. Some examples of such data sources follow.

#### **Investigation authority accident/incident data bases**

ICAO maintains the ADREP system described in Document 9156. In addition, several ICAO States maintain their own accident/incident data bases. Each follows a different format, and human performance data is accessed in each case by different methods. Since there is not yet a standard vocabulary for Human Factors in aviation accidents, or a standard taxonomy for human error causation, there is no single set of key words that one can use to find common Human Factors causes across all data bases.

Several accident bases contain valuable information, and they are well worth studying as long as the investigator is aware of the meaning of the retrieved data. All States do not use the same criteria for selecting accidents for inclusion in their data bases, so statistical analyses which involve combining data from more than one data base are risky. Even more important, data base codes (i.e. Human Factors key words) mean different things to different people. It is strongly recommended that the investigator accessing data from these data bases get assistance from the data base administrator. It is also wise for the investigator to question field investigators and coders who are responsible for coding the raw information for input into the data base. These people will be the only

ones who will be able to explain, for example, what criteria have been used when coding "mental performance overload" or "self-induced pressure" as an underlying cause factor in an accident.

#### **Manufacturer accident/incident data bases**

Several aircraft manufacturers maintain their own accident/incident data bases for their own use and for that of their customers. Some of these data bases are available to the public. One example of manufacturer accident/incident data bases which may be of interest to the investigator follows.

- Boeing Commercial Airplane Company's Product Safety Organization publishes a yearly statistical summary of commercial jet aircraft accidents, and manages both a computer-based and a hard copy data base of all commercial jet aircraft accidents (excluding Russian manufactured or operated aircraft and military operators of commercial-type aircraft). Accident data are obtained from government accident reports, operators, manufacturers, and various government and private information services. Accident selection essentially corresponds to the U.S. National Transportation Safety Board's (NTSB) accident definition. Variables of interest in this data base are phase of flight (workload considerations), aircraft type (design) cause factors (including primary flight crew).

#### **Accident/incident voluntary reporting systems**

Much valuable Human Factors information is available from largely confidential reporting systems used by several States to collect accident and incident information from involved pilots, controllers and other aviation personnel. These reporting systems are voluntary (the person experiencing, or with knowledge of, the incident is under no obligation to make a report), and usually some amount

of protection is granted to the reporter, who in most cases has committed an unintentional error while flying or controlling an aircraft. The reporter may be guaranteed some degree of immunity from legal action (e.g. suspension or revocation of pilot licence) in exchange for which the agency collecting the reports is afforded an insightful look at the conditions underlying the incident. This kind of information is nearly impossible to obtain after an accident or incident using normal investigative methods, either because the pilot is deceased or because the reporter (pilot, controller or other) is not forthcoming for fear of reprisals from the government licensing agency, police or employer.

In general, reports from involved personnel, whether gathered by an investigator post-incident or reported by the involved person to a confidential reporting system, are vulnerable to untruths and inconsistencies and should be considered by the investigator as just another piece of information to be weighted and validated. Confidential reporting systems are susceptible to misinterpretation if the investigator attempts to make statistical inferences about the data, incorrectly assuming the sample in this type of data base is comparable to the sample in a State investigative accident data base such as the ICAO ADREP data base or the NTSB data base in the United States.

Confidential reporting systems contain only information voluntarily reported. Depending upon the level of immunity accorded and upon the types of errors for which such immunity is granted, levels of reports for certain types of errors may be inflated. For example, in the United States' Aviation Safety Reporting System (ASRS), which is jointly run by the Federal Aviation Administration (FAA) and the National Aeronautics and Space Administration (NASA), a large percentage of reports involve deviations from assigned altitudes, because

pilots who report these deviations to ASRS are protected from suspensions of their licences (the common punishment for such a deviation).

Therefore, the investigator who chooses to use data from confidential reporting systems should consult administrators of these data bases to understand the significance of the data. As with the accident/incident data bases, these data can be very helpful as long as the investigator understands the scope and limitations of the data base.

Among the confidential reporting system data bases are:

Australia	CAIR P.O. Box 600 Civic Square ACT 2608
Canada	SECURITAS P.O. Box 1996 Station B Hull, P.Q. J8X 3Z2
United Kingdom	CHIRP Freepost RAF IAM Farnborough, Hants. GU14 6BR
United States	ASRS Office 625 Ellis Street, Suite 305 Mountain View, CA 94043

## Appendix 5 to Chapter 4

### REFERENCES

#### GENERAL

- Hawkins, Frank H., *Human Factors in Flight*, Gower Technical Press, 1987.
- Weiner, E., & Nagel, D., *Human Factors in Aviation*, Academic Press, 1988.
- IATA, *Airline Guide to Human Factors*, International Air Transport Association, Montreal, 1981.
- Hurst, R., & Hurst, L.R. (Eds.), *Pilot Error* (2nd Edition), Granada Publishing Ltd. London, 1978.

#### BEHAVIORAL

- Benson, A.J., & Burchard, E., *Spatial Disorientation: A Handbook for Aircrew*, NATO AGARD-AG-170, 1973.
- Robinson, J.O., *The Psychology of Visual Illusion*, Hutchinson, London, 1972.
- Bond, N.A., Bryan, G.L., Rigney, J.W., Warren, N.D., *Aviation Psychology*, University of Southern California, 1985.
- Allnutt, M., *Human Factors: Basic Principles in Pilot Error* (2nd Edition), Granada, 1983.
- Jenson, Richard S., *Aviation Psychology*, Gower Technical Press, 1989.
- Reason, J.T., *Human Error*, Cambridge University Press, New York, 1990.
- Perrow, Charles, *Normal Accidents, Living with High-Risk Technologies*, Basic Books, 1984.
- Rasmussen, J., Duncan, K., & Leplay, J. (Eds), *New Technology and Human Error*, Wiley, London, 1987.
- Sjenna, Olaf, *Cause Factor: Human. A Treatise on Rotary Wing Human Factors*, Health and Welfare Canada, 1986.
- Farmer, Eric W., *Personality Factors in Aviation*, International Journal of Aviation Safety, September 1984.
- Shaw, L., & Sichel, H., *Accident Proneness*, Pergamon Press, Oxford, 1971.
- Dinges, David F., *The Nature and Timing of Sleep*, Transactions and Studies of the College of Physicians of Philadelphia, 1984.
- Dobie, T.G., *Aeromedical Handbook for Aircrew*, NATO AGARD-AG-154, 1972.
- Green, Roger, *Alcohol and Flying*, International Journal of Aviation Safety, Vol. 1, June 1983.
- Metz, B., & Marcoux, F., *Alcoolisation et accidents du travail*, Revue de L'Alcoolisme, 1960.
- ICAO, *Manual of Civil Aviation Medicine*, Doc 8984, 1985.
- Hartzell, W. MD, *A Brief Review of Selected Areas of Aviation Medicine and Physiology*, AGARD-LS-125, 1982.
- Nicholson, Group Captain, A.N., *Circadian Rhythms and Disturbed Sleep: Its Relevance to Transport Operations*, International Journal of Aviation Safety, Vol. 1, No. 3, 1984.
- Green, Roger, *Stress and Accidents in Aviation*, International Journal of Aviation Safety, September, 1984.
- Selye, Hans, *Stress Without Distress*, J.B. Lippincott, New York, 1974.
- Haward, L.R.C., *Effects of Domestic Stress on Flying*, Revue de Médecine Aéronautique et Spatiale, 1974.
- Mohler, Stanley R. MD, *The Human Element in Air Traffic Control, Aeromedical Aspects, Problems and Prescriptions*, International Journal of Aviation Safety, Vol. 1, No. 3.

#### OPERATIONAL

- FSF, *Preflight Crew Briefings: A Step Towards Improved Communication*, 1984.
- Helmreich, R.L., *What Changes and What Endures: The Capabilities and Limitations of Training and Selection*, The Flight Operations Symposium, Irish Air Line Pilots Association/Aer Lingus, Dublin, 1983.
- Hopkins, David, V., *Human Factors in Air Traffic Control*, AGARDograph, N. 275, 1982.
- Melton, Smith et al., *Stress in Air Traffic Controllers: Comparison of Two Air Route Traffic Control Centres on Different Shift Rotation Patterns*, FAA-AM-75-7, 1975.

#### MEDICAL

- Dehning, G., Sharp, G.R., & Ernsting, J., *Aviation Medicine*, Tri-Med Books, London.

- Murrell, H., *Motivation at Work*, Methuen, London, 1976.  
 Vroom, V.H., & Deci, E.L., *Management and Motivation*, Penguin Books, Harmondsworth, 1970.

## TASK-RELATED

- Ruffell Smith, H.P., *A Simulator Study of the Interaction of Pilot Workload with Errors, Vigilance and Decision-Making*, NASA-Ames, 1979.  
 Gabriel, R.F., *Some Potential Errors in Human Information Processing During Approach and Landing*, International Symposium on Human Factors, Air Line Pilots Association, Washington, 1977.  
 Perrow, Charles, *Normal Accidents, Living with High-Risk Technologies*, Basic Books, 1984.  
 Rasmussen, J., Duncan, K., & Leplat, J. (Eds) *New Technology and Human Error*, Wiley, London, 1987.  
 Wickens, C.D., Stokes, A., & Barnett, B.J., *Componential Analysis of Decision-Making*, University of Illinois Aviation Research Laboratory Technical Report ARL-87-41 SCEE-87-1, 1987.  
 Kahneman, D., Slovic, P., & Tversky, A. (Eds.), *Judgement Under Uncertainty: Heuristics and Biases*, Cambridge University Press, New York, 1982.  
 Kahneman, D., & Tversky, A., *On the Psychology of Prediction*, *Psychological Review*, 80, 251-273, 1973.  
 Kantowitz, B.H., & Sorkin, R.D., *Human Factors: Understanding People-System Relationships*, Wiley, New York, 1983.  
 Loftus, G.R., Dark, V.J., & Williams, D., *Short-Term Memory Factors in Ground Controller/Pilot Communications*, *Human Factors*, 21, 169-181, 1979.  
 Helmreich, R.L., *Social Psychology on the Flight Deck*, Proceedings of a NASA/Industry Workshop, Resource Management on the Flight Deck, 1979.  
 Helmreich, R.L., Foushee, H.C., Benson, R., & Russini, W., *Cockpit Resource Management: Exploring the Attitude-Performance Linkage*, *Aviation, Space and Environmental Medicine*, 1986.  
 Lauber, J.K., & Foushee, H.C., *Line-Oriented Flight Training*, The Flight Operations Symposium, Irish Air Line Pilots Association/Aer Lingus, Dublin, 1983.

## EQUIPMENT

- Chapanis, A., *Ethnic Variables in Human Factors Engineering*, John Hopkins University Press, Baltimore, 1975.  
 Hawkins, F.H., *Crew Seats in Transport Aircraft*, *Shell Aviation News*, 418:14-21, 1973.  
 Hawkins, F.H., *Some Ergonomic Aspects of Cockpit Panel Design for Airline Aircraft*, *Shell Aviation News*, 437:2-9, 1976.  
 Hopkin, V.D., & Taylor, R.M., *Human Factors in the Design and Evaluation of Aviation Maps*, NATO AGARD-AG-225, 1979.  
 Stokes, A., Wickens, C., & Kite, K., *Display Concepts, Human Factors Concepts*, Society of Automotive Engineers, Inc., 1990.  
 Wilson, J.W., & Bateman, L.F., *Human Factors and the Advanced Flight Deck*, The 32nd International Air Safety Seminar, 1979.  
 Wiener, Earl L., *Human Factors of Cockpit Automation: A Field Study of Flight Crew Transition*, NASA-Ames, NCC2-152, 1985.

## ENVIRONMENTAL

- Green, R. G. *Communication and Noise*, *Aviation Medicine*, G. Dhenim (Ed.), Vol. 1, Tri-Med Books, London, 1985.  
 Rood, Dr. G., *Aircraft Cockpit and Flight Deck Noise*, *International Journal of Aviation Safety*, March 1985.  
 Mason, C.D., *Visual Landing Illusion*, *Business Aviation Safety*, 1985.  
 Mitchell, Michael K., *Bush Pilot Syndrome, A Critical Incident Analysis*, Alaskan Aviation Safety Foundation, April, 1983.  
 Transport Canada, *Flying the Alaska Highway in Canada*, TP2168.  
 Negrette, Arthur, J., *Wire Strikes: Misconceptions and Insights*, FSF Helicopter Safety Bulletin, July/October 1981.  
 Myles, W.S., & Chin, A.K., *Physical Fitness and Tolerance to Environmental Stresses: A Review of Human Research on Tolerance to and Work Capacity in Hot, Cold and High Altitude Environments*, DCIEM Report No.74-R-1008, Defence and Civil Institute of Environmental Medicine, Downsview, Ontario, 1974.



## NOTES

### Part 1, Chapter 2 — Human factors, management and organization

1. National Transportation Safety Board, Aircraft Accident Report 93/02 (NTSB/AAR-93/02).
2. Reason, James. 1987. "The Chernobyl Errors". *Bulletin of the British Psychological Society*, 40, 201-206.
3. Hendrick, Hal. 1991. "Ergonomics in Organizational Design and Management". *Ergonomics*, Vol. 34, No. 6, 743-756.
4. Bruggink, Gerard. 1990. "Reflections on Air Carrier Safety". *The Log*, 11-15.
5. Turner, B., N. Pidgeon, D. Blockley and B. Toft. 1989. "Safety Culture: Its Importance in Future Risk Management". The Second World Bank Workshop on Safety Control and Risk Management. Karlstad, Sweden.
6. Pidgeon, Nick. 1991. "Safety Culture and Risk Management in Organizations". *Journal of Cross-cultural Psychology*, Vol. 22, No. 1, 129-140.
7. Meshkati, Najmedin. 1991. "Human Factors in Large-scale Technological Systems' Accidents: Three Mile Island, Bhopal and Chernobyl". *Industry Crisis Quarterly* 5, 133-154.
8. Reason, James. 1991. *How to Promote Error Tolerance in Complex Systems in the Context of Ship and Aircraft*.
9. Reason, James. 1987. "The Chernobyl Errors". *Bulletin of the British Psychological Society*, 40, 201-206.
10. National Transportation Safety Board (NTSB), 1991. Aircraft Accident Report AAR-91/08.
11. Moshansky, The Hon. Virgil P. 1992. Commission of Inquiry into the Air Ontario Crash at Dryden, Ontario. Final Report, Vol. III.
12. Wood, Richard H. 1991. *Aviation Safety Programs — A Management Handbook*. IAP Incorporated, Casper, Wyoming, USA.
13. Hidden, Anthony (QC). 1989. Investigation into the Clapham Junction Railway Accident. The Department of Transport. London: HMSO.
14. Miller, C. O. 1991. Investigating the Management Factors in an Airline Accident. Brazilian Congress of Flight Safety, Rio de Janeiro, Brazil.
15. National Transportation Safety Board (NTSB), 1991. Aircraft Accident Report AAR-91/03.
16. Smircich, Linda. 1983. "Concepts of Culture and Organizational Analysis". *Administrative Science Quarterly*, 28, 339-358.
17. Westrum, R. 1988. "Organizational and Inter-organizational Thought". World Bank Workshop on Safety Control and Risk Management, Washington D.C.
18. A few organizations within aviation may not exactly respond to this concept. These organizations include the International Civil Aviation Organization (ICAO), the civil aviation administrations, the Flight Safety Foundation (FSF) and the International Society of Air Safety Investigators (ISASI). Since they have as a major objective the promotion and advancement of safety and effectiveness in civil aviation and they are not actively engaged in production activities, the production of safety becomes a primary goal.
19. Wood, Richard H. 1991. *Aviation Safety Programs — A Management Handbook*. IAP Incorporated, Casper, Wyoming, USA.
20. Transport Canada, 1991. Company Aviation Safety Officer Manual, Vol. 1.
21. Pope, John A. 1989. "Questions, More Questions". Flight Safety Foundation, *Flight Safety Digest*, January 1989, 1-4.
22. Helmreich, Robert L. 1992. "Human Factors Aspects of the Air Ontario Crash". Commission of the Inquiry into the Air Ontario Crash in Dryden, Ontario. Technical Appendices.
23. Hofstede, G. 1980. "Motivation, Leadership and Organization: Do American Theories Apply Abroad?" *Organizational Dynamics*, Summer 1980, 42-63.
24. Adler, Nancy J. 1991. *International dimensions of organizational behaviour* (2nd. edition). Boston: PWS-Kent Publishing Company.
25. Turner, B., N. Pidgeon, D. Blockley and B. Toft. 1989. "Safety Culture: Its Importance in Future Risk Management". The Second World Bank Workshop on Safety Control and Risk Management. Karlstad, Sweden.

26. Turner, B. 1989. "How Can We Design a Safe Organization?" Second International Conference on Industrial and Organizational Crisis Management. New York University, New York, USA.
27. Canadian Aviation Safety Board, 1986. Aviation Occurrence Report No. 84-H40006.
28. Meshkati, Najmedin. 1991. "Human Factors in Large-scale Technological Systems' Accidents: Three Mile Island, Bhopal and Chernobyl". *Industry Crisis Quarterly* 5, 133-154.
29. Fennell, D. 1988. Investigation into the King's Cross Underground Fire. The Department of Transport. London, HMSO
30. There are at least five aspects to consider in defining the environment: socioeconomic, educational, political, legal and cultural.
31. Hendrick, Hal. 1991. "Ergonomics in Organizational Design and Management". *Ergonomics*, Vol. 34, No. 6, 743-756.
32. National Transportation Safety Board, 1991. Aircraft Accident Report AAR-91/09.
33. Ministry of Justice, Major Accident Report No. 2/1988, Helsinki, 1990. Aircraft Accident Report, Embraer 110 Bandeirante, OH-EBA, in the vicinity of Ilmajoki Airport, Finland, November 14, 1988.
34. Reason, James. 1990. *Human Error*. Cambridge University Press.
35. For a full discussion on this subject, see Part 2, Chapter 4.
36. Reason, James. 1990. Op. cit.
37. Transportation Safety Board of Canada, 1990. Aviation Occurrence Report No. 89H0007.
38. Transport Canada, 1991. Aviation Safety Newsletter ASL 3/91.
39. Reason, James. 1990. Op. cit.
40. Meshkati, Najmedin. 1991. Op. cit.
41. Lautman, L. G., and P. Gallimore. 1989. "Control of Crew-caused Accidents". Flight Safety Foundation, *Flight Safety Digest*, October 1989.
42. Lauber, John K. 1989. "Human Performance and Aviation Safety — Some Issues and Some Solutions". *Airline Pilot*, June 1989.
43. National Transportation Safety Board, 1990. Aircraft Accident Report AAR-90/05.
44. Wagenaar, W., P. Hudson and J. Reason. 1990. "Cognitive Failures and Accidents". *Applied Cognitive Psychology*, Vol. 4, 273-294.
45. For additional background on this subject, see J. Lederer, C. O. Miller and C. F. Schmidt, "The Economics of Safety in Civil Aviation (Planning Study)", FAA Technical Report ADS-7, Dec. 1963.
46. Degani, A., and E. Wiener. 1991. "Philosophy, Policies, Procedures and Practices: The Four P's of Flight Deck Operations". Proceedings of the Sixth International Symposium on Aviation Psychology, Columbus, Ohio, USA.
47. British Airways Ground Proximity Warning System Policy, 4 January 1993.
48. Reason, James. 1990. *Human Error*. Cambridge University Press.
49. Wood, Richard H. 1991. Op. cit.
50. Hill, Maury. 1993. *An Assessment of Conventional Risk Management, Human Reliability Assessment and System Analysis, and their Role in Complex Man-Machine Systems*. Montreal, Canada.

**Part 1, Chapter 3 — Human factors issues in the development and implementation of communications, navigation and surveillance/air traffic management (CNS/ATM) systems**

1. For further discussion on this topic, see Harold E. Price, "Conceptual System Design and the Human Role", in *MANPRINT*, Harold R. Booyer (ed.). Van Nostrand Reinhold, New York, 1990.
2. Bainbridge, L. "Ironies of Automation", in *New Technology and Human Error*, J. Rasmussen, K. Duncan and J. Lepalt (eds.). John Wiley and Sons Ltd., 1987.
3. For further discussion on this topic, see Wiener, E.L. and D.C. Nagel, "Human Factors in Aviation, Section Two: Pilot Performance". San Diego, Academic Press, Inc., 1988; and Cooley, M.J.E., "Human Centered Systems: An Urgent Problem for System Designers". *AI and Society* 1. 1987.
4. Delta Airlines. "Statement of Automation Philosophy".
5. See Part 2, Chapter 3 — *Operational Implications of Automation in Advanced Technology Flight Decks* for other definitions of automation as used in this chapter.
6. Dr. A. Isaac, "Imagery Ability and Air Traffic Control Personnel", paper presented at the New Zealand Psychology Conference — Aviation Psychology Symposium. Massey University, Palmeston North, 1991.

7. Another study (in the United States) in cognitive psychology suggests that processing data on multiple levels (physical manipulation and repetition are two examples) should improve memory for the information being processed. However, limited information is available about how this process works in ATC and whether automation will have a negative impact on memory for flight data.

8. For a full discussion of these concerns, refer to Part 2, Chapter 3 — *Operational Implications of Automation in Advanced Technology Flight Decks*.

9. Bainbridge, L., "Ironies of Automation", in *New Technology and Human Error*, J. Rasmussen, K. Duncan and J. Lepalt (eds.). John Wiley and Sons Ltd., 1987.

10. For further reading on this subject, see Perrow, C., *Normal Accidents: Living with High-risk Technologies*. Basic Books Inc., New York, 1984.

11. For further discussion on benefits to be had from Human Factors investment at early stage, see Harold E. Price, "Conceptual System Design and the Human Role", in *MANPRINT*. Van Nostrand Reinhold, New York, 1990.

12. Reason, J., *Human Error*. Cambridge University, United Kingdom, 1990.

13. Chapter 2 — *Human Factors, Management and Organization*.

14. Ellen Goodman, "The Boston Globe Newspaper Company/Washington Post Writers Group", 1987. Quoted in Harold E. Price, "Conceptual System Design and the Human Role", in *MANPRINT*, Harold R. Boohar (ed.). Van Nostrand Reinhold, New York, 1990.

15. For further discussion on this topic, see Harold E. Price, "Conceptual System Design and the Human Role", in *MANPRINT*. Van Nostrand Reinhold, New York, 1990.

16. Wiener, E.L., "Management of Human Error by Design", Human Error Avoidance Techniques Conference Proceedings. Society of Automotive Engineers, Inc., 1988.

17. Billings, C.E., "Human-Centered Aircraft Automation: A Concept and Guidelines". NASA Technical Memorandum 103885, 1991.

18. MITRE Corporation, an engineering firm that conducts systems analysis and provides engineering technical support and guidance to the Federal Aviation Administration (FAA). In Charles E. Billings, "Human-Centered Aircraft Automation: A Concept and Guidelines". National Aeronautics and Space Administration (NASA) Technical Memorandum 103885, 1991.

19. Pfeiffer, J., "The Secret of Life at the Limits: Cogs Become Big Wheels", in *Smithsonian*, Vol. 27, No. 4, 1989.

20. Wiener, E.L. and R.E. Curry, *Ergonomics*. 1980.

21. Lane, N.E., "Evaluating the Cost Effectiveness of Human Factors Engineering". Orlando, Florida, Essex Corporation, 1987. Quoted in Harold E. Price, "Conceptual System Design and the Human Role", in *MANPRINT*. Van Nostrand Reinhold, New York, 1990.

22. Reason, J., *Human Error*. Cambridge University Press, United Kingdom, 1990.

23. See Charles E. Billings, "Human-Centered Aircraft Automation: A Concept and Guidelines". National Aeronautics and Space Administration (NASA) Technical Memorandum 103885, 1991.

#### **Part 1, Chapter 5 — Human factors issues in air traffic control**

1. The SHEL model is described in Chapter 1.

2. For a complete explanation of the concept of systems, refer to Chapter 3 — *Ergonomics*.

3. For the ergonomic aspects of ATC workspace design, see Chapter 3 — *Ergonomics*.

4. Wise, Hopkin and Smith (1991). *Automation and Systems Issues in Air Traffic Control*.

5. See also Chapter 2 — *CNS/ATM Systems (Wiener's "Iron Law")*.

6. EATCHIP is the European ATC Harmonisation and Integration Programme. The Human Resources Team has produced a booklet on "Guidelines for Developing and Implementing Team Resource Management".

7. One of the most recent studies published at the time of writing is a working paper by the International Labour Office (ILO) in Geneva, titled "Occupational stress and stress prevention in air traffic control" (ISBN 92-2-110070-7).

#### **Part 1, Chapter 6 — Human factors in aircraft maintenance and inspection**

1. TechLog — "Is There a Maintenance Problem." *AEROSPACE*, June 1993.

2. Reason, J. 1993. *Comprehensive Error Management (CEM) in Aircraft Engineering*.

3. Drury, C.G. "Errors in Aviation Maintenance: Taxonomy and Control". Proceedings of the Human Factors Society 35th Annual Meeting, 1991, pp. 42-46.
4. Hollnagel, E. *Human Reliability Analysis — Context and Control*. Academic Press, San Diego, CA, 1993.
5. Marx, D.A. and R.C. Graeber. *Human Error in Aircraft Maintenance*. Boeing Commercial Airplane Group, Seattle, Washington, 1993.
6. National Transportation Safety Board. "Aviation Accident Report, American Airlines DC-10, Chicago, 1979" (NTSB/AAR-79/17). Washington, D.C., 1979.
7. Boeing 747 SR-100, JA8119, "Accident at Gunma Prefecture, Japan, on 12 August 1985". Report released by the Aircraft Accident Investigation Commission, Japan.
8. National Transportation Safety Board. "Aircraft Accident Report, Aloha Airlines Flight 243". Boeing 737-200, N73711, Near Maui, Hawaii, 28 April 1988 (NTSB/AAR-89/03). Washington, D.C., 1989.
9. Sears, R.L. 1986. "A new look at accident contributions and the implications of operational training programs" (unpublished report). Quoted in Graeber, R.C. and D.A. Marx. *Reducing Human Error in Aviation Maintenance Operations*. (Presented at the Flight Safety Foundation 46th Annual International Air Safety Seminar. Kuala Lumpur, Malaysia, 1993.)
10. United Kingdom Civil Aviation Authority (UK CAA). "Maintenance Error". *Asia Pacific Air Safety*. September 1992.
11. Graeber, R.C. and D.A. Marx. *Reduced Human Error in Aircraft Maintenance Operations*. 1993.
12. Summarized from "Finger-Tight at 290 (a tale of the unexpected)". Robin Rackham, *Log*, BALPA, August/September 1993.
13. National Transportation Safety Board. "Aircraft Accident Report, Eastern Airlines Inc., L-1011". Miami, Florida, 5 May 1983 (NTSB/AAR-84/04). Washington, D.C.
14. AAIB Aircraft Accident Report 1/92. "Report on the Accident to BAC One-Eleven, G-BJRT" over Didcot, Oxfordshire on 10 June 1990. London: HMSO.
15. National Transportation Safety Board. "Aircraft Accident Report, Continental Express Flight 2574". In-Flight Breakup, EMB-120RT, N33701. September 1991 (NTSB/AAR-92/04). Washington, D.C., 1992.
16. National Transportation Safety Board. "Aircraft Accident Report, Eastern Airlines Inc., L-1011". Miami, Florida, 5 May 1983 (NTSB/AAR-84/04). Washington, D.C.
17. Ibid. For detailed analysis of Human Factors issues in this particular incident, see Marx, D.A. and R.C. Graeber. *Human Error in Aircraft Maintenance*. Boeing Airplane Commercial Group, Seattle, Washington, 1993.
18. For a more detailed discussion on this subject, see *Chapter 2 — Human Factors, Management and Organization*. 1993.
19. AAIB Aircraft Accident Report 1/92. "Report on the Accident to BAC One-Eleven, G-BJRT" over Didcot, Oxfordshire on 10 June 1990. London: HMSO *causal factors (emphasis added)*, pp. 54.
20. "From Individuals to Organizations". ICAO position paper delivered at the Algonquin College validation course on aviation Human Factors. February 1993.
21. National Transportation Safety Board. "Aircraft Accident Report, Continental Express Flight 2574". In-Flight Breakup, EMB-120RT, N33701, September 1991 (NTSB/AAR-92/04). Washington, D.C., 1992.
22. Ibid. pp. 54. John K. Lauber, Member NTSB. "Dissenting Statement".
23. Ibid. pp. 52-54 (an adaptation and emphasis added).
24. National Transportation Safety Board. "Aircraft Accident Report, United Airlines Flight 232, McDonnell Douglas DC-10-10". Sioux Gateway Airport, Sioux City, Iowa, 19 July 1989 (NTSB/AAR-90/06). Washington, D.C., 1990.
25. See Marx, D.A. and R.C. Graeber. *Human Error in Aircraft Maintenance*. Boeing Commercial Airplane Group, Seattle, Washington, 1993.
26. National Transportation Safety Board. "Aircraft Accident Report, Continental Express Flight 2574", In-Flight Breakup, EMB-120RT, N33701. September 1991 (NTSB/AAR-92/04). Washington, D.C. 1992.
27. For a detailed discussion on Human Factors and corporate or organizational culture, see *Chapter 2 — Human Factors, Management and Organization*.
28. AAIB Aircraft Accident Report 1/92, "Report on the Accident to BAC One-Eleven, G-BJRT" over Didcot, Oxfordshire on 10 June 1990, London: HMSO.
29. For a full discussion about CRM, refer to Part 2, Chapter 2 — *Flight Crew Training: Cockpit Resource Management (CRM) Training*.

30. Robertson, M., J. Taylor, J. Stelly and R. Wagner. "Maintenance CRM Training". Assertiveness attitudes effect on maintenance performance in a matched sample. WEAAP Conference. March 1994, Dublin. See also Stelly, J. and J. Taylor, "Crew Coordination Concepts for Maintenance Teams". Proceedings of the 7th International Symposium on Human Factors in Aircraft Maintenance and Inspection, 1992. Washington D.C.

31. For a complete explanation of these concepts, read Campbell, R.J. "Measurement of Workforce Productivity". Proceedings of the Fifth Federal Aviation Administration Meeting on Human Factors Issues in Aircraft Maintenance and Inspection — The Work Environment in Aviation Maintenance. January 1992. Washington, D.C.

32. For a detailed presentation on *human-centred automation*, see Chapter 6.

33. From Marx, D.A. and C.R. Graeber (1994). *Human Error in Aircraft Maintenance*. In N. McDonald, N. Johnston, and R. Fuller (Eds.), *Aviation Psychology in Practice*. Aldershot — Ashgate Press.

34. Ibid.

35. Barnett, M.L. 1987. *Factors in the Investigation of Human Error in Accident Causation*. College of Maritime Studies. Warsash, Southampton, United Kingdom.

36. National Transportation Safety Board. "Aircraft Accident Report, Aloha Airlines Flight 243", Boeing 737-200, N73711, Near Maui, Hawaii, April 28, 1988 (NTSB/AAR-89/03). Washington, D.C. 1989.

37. Johnson, W.B. and W.B. Rouse. 1982. *Analysis and Classification of Human Errors in Troubleshooting Live Aircraft Power Plants*. IEEE. Transactions on Systems, Man and Cybernetics.

#### Part 2, Chapter 2, Appendix 1

1. Advisory Circular (Draft 1.1), CRM/LOFT Working Group, Training Subcommittee, Joint Government/Industry Task Force on Crew Performance — October 30, 1987.
2. Advisory Circular — October 30, 1987.
3. Advisory Circular — October 30, 1987 September 26, 1988.

#### Part 2, Chapter 3 — Training issues in automation and advanced technology flight decks

1. There are two levels of systems management which must be considered in flight deck design: *aircraft control* (inner loop, exercising psychomotor skills), and *aircraft monitoring* (outer loop, demanding cognitive abilities).

2. Flight directors gave, for the first time, "command information". The raw data were available to the pilot, but it was not always used as a check or monitor of the integrated information presented by the flight director.

3. Distrust is one of the biggest factors in system design. If a system is designed so that it will always do what the pilots think it should do, and *never* does what the pilots think it should not do, it is probably a good design (see Wiener-Curry principle No. 1, Appendix II). This point should be kept in mind by certification test pilots, who should not compromise when evaluating a system and its operation.

4. For a complete discussion on LOFT, refer to Chapter 20.

5. Trans-cockpit authority gradient is the authority relationship between captain and first officer. For example, in the case of a domineering captain and an unassertive first officer, the gradient will be steep. If two captains are rostered together, the gradient may be shallow.

#### Part 2, Chapter 4 — Human factors training for safety investigators

1. James Reason, "Human Error", Cambridge University Press, New York, 1990, p. 302. See also Part 1, Chapter 2 of this manual.

2. Besco, R.O., "Why Pilots Err: What can we do about it?", paper published in *Forensic Reports*, Vol. 4, No. 4 (1991), pages 391-416.

3. "The Role of Analysis in the Fact-finding Process", Society of Air Safety Investigators, *Forum*, 1975.

4. Ibid.

5. Ronald L. Schleede, "Application of a Decision-making Model to the Investigation of Human Error in Aircraft Investigation", ISASI Forum, 1979.
6. Richard Wood, "Aircraft Accident Report Development", *Forum*, Vol. 22, No. 4, 1989.
7. Ibid.
8. Richard Wood, "How Does the Investigator Develop Recommendations?", *Forum*, Vol. 12, No. 3, 1979.

— END —